

Cam Followers

RBC Roller[®], HexLube[®], CamCentric[™]



A Wide Array of Products Including RBC Roller[®], Cylindrical and Needle Roller Cam Followers—both Stud and Yoke Styles

Smoother. Faster. Longer.
Because That's How We Roll.



RBC Bearings® provides global industrial, aerospace, and defense customers with unique design solutions to complex problems and an unparalleled level of service, quality, and support.

RBC manufactures highly engineered precision plain, roller and ball bearings, shaft collars, rigid couplings and keyless locking devices. While RBC designs and manufactures products in these major product categories, RBC excels at solving the most demanding and difficult applications with solutions that improve customers' products and process performance and deliver the lowest total cost of ownership. This has been achieved by providing products such as maintenance free bearings, components, and bearings designed

to withstand environments with extreme temperature, high speed, contamination, corrosion, and severe shock loading.

RBC Bearings® has been providing engineered solutions to customers since 1919. RBC has significantly broadened our end markets, products, customer base and geographic reach through organic growth and through acquisitions. These acquisitions fit well with our philosophy of providing high quality products and solutions to our customer base. They have enhanced our customer solutions and experience, further diversifying our offering to our target markets.

RBC currently has 42 facilities in five countries, with manufacturing in 33 locations.





RBC Bearings® has had a long tradition of innovation, commitment, and quality since the company was founded in 1919. Today, RBC Bearings® has grown into a world-class manufacturer of standard and custom-engineered bearings and related products, with a product focus on research, testing, and development of the best product for specific applications.

What We Manufacture

RBC Bearings®, with facilities throughout North America and Europe, provides bearings and precision products for applications in the construction, mining, material handling, transportation and off-highway equipment, robotics and automation, farming, machine tool, and semiconductor equipment industries. Through RBC Aerospace Bearings®, the company is a major manufacturer of highly-engineered bearings and precision products for military, defense, and commercial aerospace applications.

RBC's High-Quality Bearings Include:

- **Heavy Duty Needle Roller Bearings** - Pitchlign® caged heavy duty needle roller bearings, inner rings, type TJ TandemRoller® bearings for long life.
- **Spherical Plain Bearings** - Radial, angular, contact, high misalignment, extended inner ring, DuraLube™ maintenance-free spherical plain bearings, QuadLube® long life bearings, ImpactTuff® case carburized bearings, ShimPack® double-acting angular contact bearings, CrossLube® lubrication groove systems, and SpreadLock® Seal.
- **Cam Followers and Yoke Rollers** - Standard stud, heavy stud, yoke type, caged roller followers, RBC Roller® long life cam followers, HexLube® universal cam followers, airframe track rollers. Mastguide rollers and carriage rollers, chain sheaves (for leaf chain), toothless sprockets (for roller chain), and heavy-duty roller bearing construction.
- **Rod Ends** - Commercial and aerospace, precision, Mil-Spec series, self-lubricating, inch and metric. Heim®, Unibal®, and Spherco® brands.
- **Self-Lubricating Bearings** - Radial, thrust, rod ends, spherical plain bearings, high temperature, high loads, inch and metric. Fiberglide®.
- **Thin Section Ball Bearings** - Standard cross sections to one inch. Sizes to 40 inches. Stainless steel and other materials available. Seals available on all sizes and standard cross sections.
- **Airframe Control Bearings** - Ball bearing types, self-lubricating types, needle roller track rollers.
- **Ground, Semiground, and Unground Ball Bearings** - Full complement, utilizes design and burnished races for higher loads, long life, and smooth operation.
- **Dowel Pins, Loose Needle Rollers, Shafts**
- **Tapered Roller Thrust Bearings** - Case-hardened. Sealed and unsealed for truck, tractor, and construction equipment steer axles, and Class 8 trailer landing gear.
- **Custom Designed Bearings** - RBC produces a wide range of custom bearings in various materials for specific applications.

RBC Cam Followers

RBC Bearings® produces an extensive cam follower product line from 1/2 inch roller O.D. to 10 inch roller O.D. Standard stud, heavy stud, and yoke types are made in sealed and unsealed configurations. The caged SRF roller is popular in applications requiring oil bath lubrication, high speed, or in applications greased for life.

RBC Bearings® produces metric cam followers where volume permits. Contact RBC Bearings® for availability.

Unique cam follower products offered include:

- **RBC Roller®** - A long life cam follower, the RBC Roller has been developed for use in applications that cannot be compromised. The RBC Roller offers an average 400% life improvement over needle bearing cam follower designs and can substantially reduce operating costs.
- **HexLube®** - RBC stud type cam followers have a new HexLube feature and come equipped with a grease fitting installed in the roller end, thus permitting relubrication. HexLube® can reduce inventory by 50% by consolidating other varieties of cam followers and interchanging them with HexLube.
- **CamCentric™** - The RBC CamCentric™ cam follower allows the user to adjust the height at which the cam follower rides along the track.

How We Can Serve You

RBC Bearings® has implemented a total quality control system that uses statistical quality control at all facilities, and manufactures in high volume to a just-in-time program.

To serve the ongoing needs of customers, RBC Bearings® has a network of over 2,400 distributors and sales engineers throughout North and South America and Europe, with authorized agents worldwide. For assistance with your bearing application:



Call Us:
800.390.3300



Email:
info@RBCbearings.com
aeroinfo@RBCbearings.com



Shop with Us:
<https://www.rbcshop.com>

Warranty

RBC products are warranted for material and workmanship for a period not to exceed 90 days from shipment and for a value not to exceed purchase price. No other warranty is in effect.

Disclaimer and Intellectual Property Statement

The materials comprising this Catalog are provided by RBC Bearings Incorporated ("RBC Bearings", "RBC") as a service to its customers on an "as-is" basis for informational purposes only. RBC assumes no responsibility for any errors or omissions in these materials. RBC makes no commitment to update the information contained herein.

RBC makes no, and expressly disclaims any, representations or warranties, express or implied, regarding the Catalog, including, without limitation, any implied warranties of merchantability or fitness for a particular purpose. RBC makes no, and expressly disclaims any, warranties, express or implied, regarding the correctness, accuracy, completeness, timeliness, and reliability of the text, graphics and any other items in the Catalog. Under no circumstances shall RBC, its affiliates, or any of their respective partners, officers, directors, employees, agents or representatives be liable for any damages, whether direct, indirect, special or consequential damages for lost revenues, lost profits, or otherwise, arising from or in connection with this Catalog and the materials contained herein.

All materials contained in the Catalog are protected by copyright laws, and may not be reproduced, republished, distributed, transmitted, displayed, broadcast or otherwise exploited in any manner without the express prior written permission of RBC.

RBC's names and logos and all related trademarks (including RBC Part Numbers, Series Number, and Cone and Cup Numbers), tradenames, and other intellectual property are the property of RBC Bearings and cannot be used without its express prior written permission.

Smoother. Faster. Longer.

Because That's How We Roll.

Product Overview

- ✓ Ball Bearings
- ✓ Cam Followers
- ✓ Cylindrical Roller Bearings
- ✓ Dowel Pins
- ✓ Heavy Duty Needle Roller Bearings
- ✓ Integrated Assemblies
- ✓ Keyless Locking Assemblies
- ✓ Keyless Rigid Couplings
- ✓ Loose Needle Rollers and Shafts
- ✓ Maintenance-Free Bearings
- ✓ Rigid Couplings
- ✓ Rod Ends
- ✓ Self-Lubricating/Lined Bearings
- ✓ Shaft Collars
- ✓ Shrink Discs
- ✓ Spherical Plain Bearings
- ✓ Tapered Roller Bearings
- ✓ Tapered Roller Thrust Bearings
- ✓ Thin Section Ball Bearings

Industrial Markets Served

- ✓ Automation
- ✓ Construction
- ✓ Food & Beverage
- ✓ Material Handling
- ✓ Mining
- ✓ Oil & Gas
- ✓ Packaging Machinery
- ✓ Refuse & Recycling
- ✓ Renewable Energy
- ✓ Military & Defense
- ✓ Power Generation
- ✓ Robotics
- ✓ Semiconductor
- ✓ Transportation
- ✓ Hydropower & Dams

Custom Engineered Solutions

- ✓ Maintenance-Free Bearings
- ✓ Bearings & Components for Harsh Environments
 - Extreme Temperatures
 - High Speed
 - Contamination
 - Corrosion
 - Shock Loading
- ✓ Advanced Sub-Assemblies





Cam Follower Selection Guide

6-7



RBC Roller®

Patented Cam Follower Design for Extended Life
Series: RBC-CRBC, RBY-CRBY, HRBC-CHRBC

8-15



Stud Type Cam Followers

HexLube® Series Universal Cam Followers:
S-LW, CS-LW, S-LWX, CS-LWX, H-LW, CH-LW
Additional Series: S, S-L, CS-L, H, H-L, CH-L

16-27



Yoke Type Cam Followers

Series: Y, Y-L, CY-L

28-29



Caged Roller Followers and Inner Rings

Series: SRF, SRF-S, SRF-SS, SRF-R, SRF-RR, IR

30-33

$$L_{10 \text{ rev}} = \left(\frac{C}{P} \right)^{\frac{3}{10}}$$

Technical Data

34-39

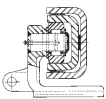

Typical Applications

40-42



RBC Cam Follower Interchange Tables

43-49



Custom Designed Cam Followers

50

Cam Follower Selection Guide

RBC Cam Followers are presented in three groups: Needle Roller Cam Followers; Caged Roller Followers; RBC Roller® Long Life Cam Followers. RBC also produces a wide range of custom designed cam followers and track rollers. Designers and users with unusual application requirements should contact RBC to discuss custom designed cam followers.

Savings at Every Turn!

RBC Bearings produces the most innovative line of cam followers in the industry. The entire line is made from bearing quality steel for optimum performance. From the patented, long-life, RBC Roller® Cam Follower to the inventory reducing HexLube® line, RBC achieves cost savings and provides features that are unmatched by competitors. If you have a special application that is not served by the exhaustive list of products shown in this catalog, RBC has the engineering resources to create custom designed cam followers that will meet your needs.

RBC Roller®

The patented RBC Roller® is the leading cost-saver in the industry. This long-life cam follower lasts up to 400% longer than standard cam followers, with no maintenance! You can calculate your savings at our interactive website www.rbcbearings.com.

The RBC Roller® is dimensionally interchangeable with needle roller cam followers. The RBC Roller® is a good selection for production machinery applications where down time is critical and must be avoided, or where cam followers are not readily accessible for relubrication or replacement. They are available in stud type (page 10) and yoke type (page 14) configurations.

Two paths of end-guided, cylindrical rollers provide substantial increases in fatigue life and limiting speed. They can tolerate higher thrust loads than needle roller cam followers. Standard contacting lip seals offer enhanced protection against contaminants and positive grease retention. A large internal grease cavity assures maintenance-free service. Hex sockets are a standard feature. Crowned outer rings are available as an option.

HexLube®

RBC's new Universal HexLube® line of cam followers can reduce your inventory by about 50%! This innovative line can eliminate the need for you to stock screwdriver slot or unsealed cam followers. Find out how much your inventory can be reduced at www.rbcbearings.com.

The new HexLube feature allows hex head cam followers to be relubricated through the hex head—a great convenience in tight spaces or when stud access is

impossible. This feature is now available in sizes from 3/4" to 7" with either a standard stud or heavy stud. Eccentric and crowned versions are also available. Standard hex head cam followers are available in smaller sizes starting at 1/2".

Needle Roller Cam Followers

Needle Roller Cam Followers have a heavy outer ring cross section and a full complement of needle rollers. They offer high dynamic and static load carrying capability, and anti-friction performance, in a compact design. They are used as track rollers, cam followers, and in a wide range of linear motion systems.

Standard Stud cam followers (page 18) offer the mounting convenience of a threaded stud and are designed to accommodate moderate loads. They are available with and without seals. Standard stud cam followers are also available with crowned outer rings (page 20) for applications where misalignment is a problem.

Heavy Stud cam followers (page 24) are designed to provide additional stud strength for applications with high loading or shock loads. Heavy stud cam followers are available with and without seals, and with crowned outer rings (page 26).

Yoke Type cam followers (page 28) are intended primarily for applications where loading conditions exceed the capabilities of stud type cam followers, or where clevis mounting is desired. Clevis mounting provides support on both sides of the cam follower and permits use of a high strength pin. Yoke type cam followers are available with and without seals, and with crowned outer rings.

CamCentric™ adjustable cam followers (page 22) are used where accurate positioning is required. They are particularly useful for reducing clearance or backlash in opposed arrangements, and for assuring load sharing in multiple cam follower installations. Seals and hex socket are standard features of CamCentric™ adjustable cam followers. Crowned outer rings are also available.

Crowned Outer Rings are used to minimize outer ring thrusting in applications where the axis of the cam follower is not parallel to the surface of the track or is skewed relative to the direction of travel. Crowned outer rings are a good selection for use with curved or circular tracks. In well aligned applications, crowned outer rings can cause accelerated track wear.

Caged Roller Followers

Caged roller followers (page 30) provide large internal grease storage capacity for applications where relubrication is infrequent. Cage guided rollers and a very heavy outer ring cross section permit operation at

Cam Follower Selection Guide

high loads and high speeds. Caged roller followers are available with and without seals. The unsealed design provides the additional advantages of very low friction to prevent skidding in lightly loaded applications and provides for flow-through lubrication.

Caged roller followers normally mount directly on a hardened and ground pin. RBC offers a line of Precision Ground Inner Rings (page 32) to simplify application of caged roller followers. More information on shaft and mounting considerations is provided in part 5.4 of the technical section (page 38).

Application Requirements		Needle Roller Cam Followers					Caged Roller Follower	RBC Roller®
		Standard Stud	Heavy Stud	Yoke Type	CamCentric™	Crowned Outer Ring		
Dynamic Loading	Moderate	✓			✓			✓
	Heavy		✓				✓	
	Very Heavy			✓				
Shock Loading			✓	✓				
High Static Loads			✓	✓				
Thrust Load								
Contamination								✓
Maintenance Free								✓
Long Life							✓	✓
Misalignment						✓		✓
Load Sharing					✓			
Adjustability					✓			
High Speed							✓	✓
Low Friction							✓	
Circular Track						✓		
See Pages		18-19	24-25	28-29	22-23	*	30-33	10-15

* Standard Stud - Page 20 Heavy Stud - Page 26 Yoke Type - Page 28

RBC Roller® Cam Followers

Stud & Yoke Type



C

C = Crowned O.D.

HRBC

HRBC = Heavy Stud (Hex Head)

RBC = Standard Stud (Hex Head)

RBY = Yoke Roller

2 1/4

Outer Ring Diameter = in Inches

OH

OH = Oil Holes

LU = Special Grease

NS = without Seals

CR = Corrosion Resistant

NNW = 2 Jam Nuts & Washer

The **RBC Roller®** was developed for customers needing a high degree of assurance of long cam follower life. It can be used to great advantage in conveyors, automotive transfer lines or process industries—food, beverage, plastics, glass and others. The **RBC Roller®** is also attractive for defense applications, where system reliability and maintainability are primary design goals. The internal design and construction differ from typical needle bearing, ball bearing, and tapered roller bearing cam followers. The **RBC Roller®** has several unique design features that enable it to outperform a standard needle roller cam follower. RBC also has several special designs based on the **RBC Roller®** concept, some of which are patented. To see patented special designs, visit www.rbcbearings.com/patents.

Two paths of cylindrical rollers create stable outer ring support. The comparatively large diameter of the rollers provides substantially increased dynamic capacity and fatigue life. On a size by size basis, the **RBC Roller®** offers at least twice, and up to nine times the fatigue life of conventional needle roller bearing cam followers.

A center thrust ring in the **RBC Roller®** imparts end guidance to the two paths of rollers. Conventional needle roller bearing cam followers rely on outer ring curvature and controlled circumferential clearance for roller guidance. The needle rollers often skew during normal operation, generating unnecessary heat which can lead to premature failure. When compared to needle roller bearing cam followers, end-guided cylindrical rollers allow the **RBC Roller®** to run at lower operating temperatures and higher speeds.

Thrust loading in the **RBC Roller®** is accommodated through contact between outer ring flanges and roller ends, and contact between roller ends and the center thrust ring. This provides the **RBC Roller®** with superior thrust capability. As a result, the **RBC Roller®**

is tolerant of tracking misalignment and axial loads that would overwhelm other designs.

Contacting lip seals are a standard feature of the **RBC Roller®**. These seals ride on smooth ground surfaces on the inner ring or stud. This sealing system provides positive exclusion of solid and liquid contaminants, and excellent lubricant retention. When compared to clearance seals typical of most cam follower designs, the **RBC Roller®** contacting lip seals ensure superior protection in demanding environments.

The **RBC Roller®** is pre-lubricated at the factory with a high quality mineral oil, NLGI grade 2 grease. The space between the two paths of rollers which is created by the center thrust ring provides a large grease storage cavity. This larger than normal ability to store lubricant, in combination with excellent grease retention of the contacting lip seals, makes the **RBC Roller®** virtually maintenance-free. Under most operating conditions relubrication is not necessary.

The design of the **RBC Roller®** provides the additional benefit of positive, unitized construction. Conventional cam followers rely on swaging or staking, particularly in yoke type configurations, to maintain integrity of the assembly. If adequate axial clamping is not provided, these designs can drift apart and cause catastrophic failure. During assembly of the **RBC Roller®**, the center thrust ring permanently engages a circumferential groove in the stud or inner ring. This design feature ensures integrity of the assembly during handling and operation, and simplifies mounting design.

The **RBC Roller®** is available in stud and yoke type configurations. Standard sizes range from 1 to 10 inches outside diameter for RBC and RBY series, and 1 1/2 to 6 inches outside diameter HRBC series. The **RBC Roller®** is dimensionally interchangeable with standard needle roller bearing cam follower designs.

RBC Roller® Cam Follower

Patented RBC Roller® double row cylindrical roller cam followers represent the most effective cam follower technology available. They are superior to needle roller cam followers in every way—lubed for life, higher load capacity, higher speed rating, and longer service life.

Contacting Lip Seals

These seals make contact only with the stud ground diameter, therefore maximizing seal life. They are not subject to thrust load against unground surfaces. Their sole function is to provide a secure seal for the retention of lubricant and exclusion of contaminants.

Dual Row Cylindrical Rollers

Large diameter rollers carry high loads. Higher dynamic capacity results in greater fatigue life—greatly prolonging cam follower service life.

Center Thrust Ring

A unique element of the RBC Roller design, the center thrust ring aids in roller guidance and sustains thrust loads generated by cam follower misalignment. Available only in RBC's patented design.

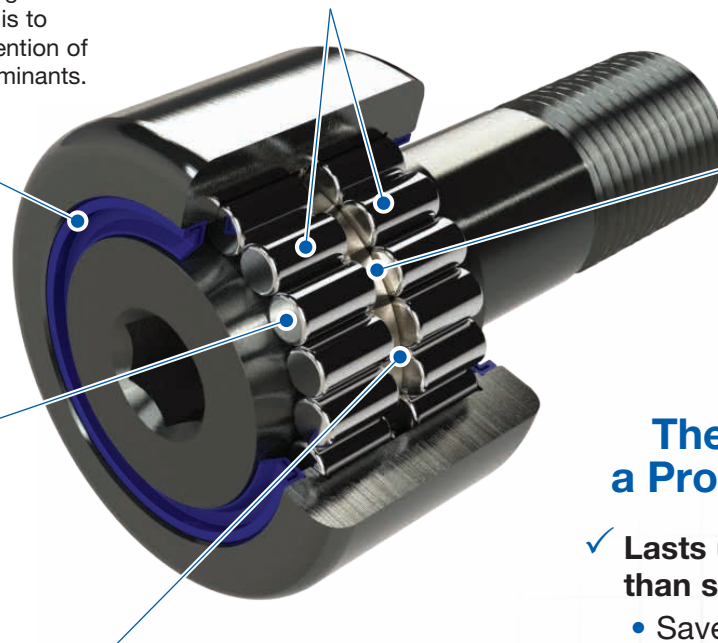

Precise Roller Guidance

RBC Roller® cam followers typically run cooler than the needle roller cam follower. Cylindrical rollers are guided by both the center thrust ring and internal shoulders of the outer ring.

Large Grease Reservoir

Area between the roller paths is fully charged with up to 4 times more grease than like-sized needle roller cam followers. This additional grease helps to ensure lubed for life performance. Eliminates the need for periodic relubrication.

The RBC Roller® — a Proven Cost-Saver!!!

- ✓ **Lasts up to 4 times longer than standard cam followers**
 - Saves replacement costs
 - Saves downtime costs
- ✓ **Maintenance-Free**
 - Saves maintenance costs
 - Saves lubrication costs
 - Saves time
- ✓ **Increased speeds**
 - Boosts productivity
- ✓ **Lower running temperature—approximately 50°F cooler**
- ✓ **Interchangeable with Needle Bearing Cam Followers**

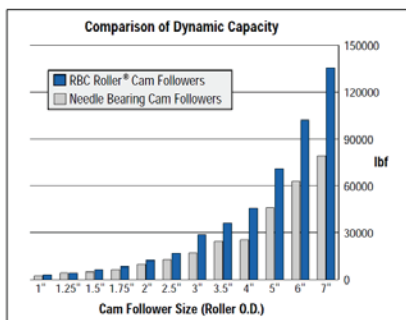

This chart shows the superior load capacity of the RBC Roller® cam follower.

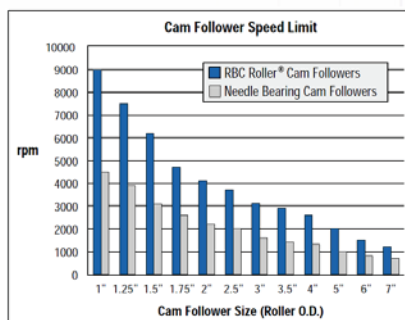

RBC Roller® cam followers operate at speeds up to 2 times higher than needle roller cam followers.

RBC Roller®

Long-Life Cam Followers

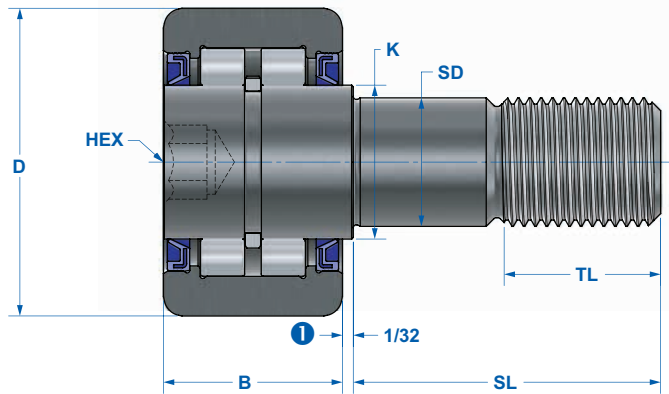

Series RBC, CRBC

PART NUMBER		ROLLER			STUD					APPROX. WEIGHT [lbs]
		D	B	CR	SD	SL	K	TL	Thread Class 2A	
		Outside Diameter + .000 - .001	Roller Width + .000 - .005	Crown Radius	Shank Diameter + .001 - .000	Shank Length	Shoulder Diameter	Eff. Thread Length		
RBC 1	CRBC 1	1.000	0.625	12	0.4375	1.000	0.500	0.500	7/16-20	0.16
RBC 1 1/8	CRBC 1 1/8	1.125	0.625	12	0.4375	1.000	0.500	0.500	7/16-20	0.19
RBC 1 1/4	CRBC 1 1/4	1.250	0.750	14	0.5000	1.250	0.625	0.625	1/2-20	0.29
RBC 1 3/8	CRBC 1 3/8	1.375	0.750	14	0.5000	1.250	0.625	0.625	1/2-20	0.34
RBC 1 1/2	CRBC 1 1/2	1.500	0.875	20	0.6250	1.500	0.750	0.750	5/8-18	0.51
RBC 1 5/8	CRBC 1 5/8	1.625	0.875	20	0.6250	1.500	0.750	0.750	5/8-18	0.61
RBC 1 3/4	CRBC 1 3/4	1.750	1.000	20	0.7500	1.750	1.000	0.875	3/4-16	0.83
RBC 1 7/8	CRBC 1 7/8	1.875	1.000	20	0.7500	1.750	1.000	0.875	3/4-16	0.92
RBC 2	CRBC 2	2.000	1.250	24	0.8750	2.000	1.125	1.000	7/8-14	1.32
RBC 2 1/4	CRBC 2 1/4	2.250	1.250	24	0.8750	2.000	1.125	1.000	7/8-14	1.61
RBC 2 1/2	CRBC 2 1/2	2.500	1.500	30	1.0000	2.250	1.250	1.125	1-14	2.48
RBC 2 3/4	CRBC 2 3/4	2.750	1.500	30	1.0000	2.250	1.250	1.125	1-14	2.83
RBC 3	CRBC 3	3.000	1.750	30	1.2500	2.500	1.500	1.250	1 1/4-12	4.04
RBC 3 1/4	CRBC 3 1/4	3.250	1.750	30	1.2500	2.500	1.500	1.250	1 1/4-12	4.75
RBC 3 1/2	CRBC 3 1/2	3.500	2.000	30	1.3750	2.750	1.625	1.375	1 3/8-12	6.22
RBC 4	CRBC 4	4.000	2.250	30	1.5000	3.500	1.750	1.500	1 1/2-12	7.44
RBC 5	CRBC 5	5.000	2.750	48	2.0000	5.062	2.250	2.562	2-12	18.70
RBC 6	CRBC 6	6.000	3.250	56	2.5000	6.000	3.000	3.000	2 1/2-12	32.90
RBC 7	CRBC 7	7.000	3.750	60	3.0000	7.688	3.750	4.125	3-12	53.50
RBC 8	CRBC 8	8.000	4.250	40	3.2500	8.500	4.000	4.250	3 1/4-4	73.60
RBC 9	CRBC 9	9.000	4.750	40	3.7500	9.500	4.500	4.750	3 1/2-4	102.70
RBC 10	CRBC 10	10.000	5.250	40	4.2500	10.000	5.000	4.750	3 1/2-4	137.00

All dimensions are in inches.

To specify RBC Roller® with lubrication holes, add OH suffix (example: RBC 1 1/2 OH).

Seals can be removed for flow-through lubrication.

To specify RBC Roller® without seals, add NS suffix (example: RBC 4 NS).



Series RBC, CRBC

SOCKET HEAD WRENCH SIZE	SPEED LIMIT [rpm]	CAPACITIES				MOUNTING DATA		PART NUMBER	
		C	C ₀	Max. Allowable Load [lbf]	Track Capacity @ 40 Rc [lbf]	Max. Clamping Torque [in*lbf] ②	Housing Bore + .0005 - .0002		
		Dynamic Capacity [lbf]	Static Capacity [lbf] ③						
3/16	9,400	3,000	3,200	1,400	1,660	100	0.4375	RBC 1	CRBC 1
3/16	9,400	3,000	3,200	1,700	1,870	100	0.4375	RBC 1 1/8	CRBC 1 1/8
1/4	7,500	4,100	4,300	1,500	2,440	180	0.5000	RBC 1 1/4	CRBC 1 1/4
1/4	7,500	4,100	4,300	1,850	2,680	180	0.5000	RBC 1 3/8	CRBC 1 3/8
5/16	6,200	6,200	7,000	2,400	3,320	390	0.6250	RBC 1 1/2	CRBC 1 1/2
5/16	6,200	6,200	7,000	2,800	3,600	390	0.6250	RBC 1 5/8	CRBC 1 5/8
5/16	4,700	8,200	10,500	3,150	4,550	750	0.7500	RBC 1 3/4	CRBC 1 3/4
5/16	4,700	8,200	10,500	3,800	4,900	750	0.7500	RBC 1 7/8	CRBC 1 7/8
7/16	4,100	12,400	17,200	5,500	6,500	900	0.8750	RBC 2	CRBC 2
7/16	4,100	12,400	17,200	7,000	7,300	900	0.8750	RBC 2 1/4	CRBC 2 1/4
1/2	3,700	16,800	22,800	9,100	9,400	1,300	1.0000	RBC 2 1/2	CRBC 2 1/2
1/2	3,700	16,800	22,800	10,900	10,400	1,300	1.0000	RBC 2 3/4	CRBC 2 3/4
5/8	3,100	28,900	39,100	15,000	13,300	2,000	1.2500	RBC 3	CRBC 3
5/8	3,100	28,900	39,100	17,800	14,400	2,000	1.2500	RBC 3 1/4	CRBC 3 1/4
5/8	2,900	36,100	53,000	21,200	17,300	2,500	1.3750	RBC 3 1/2	CRBC 3 1/2
3/4	2,600	45,600	68,000	23,700	22,000	3,000	1.5000	RBC 4	CRBC 4
7/8	2,000	71,000	110,000	43,700	35,000	3,000	2.0000	RBC 5	CRBC 5
1	1,500	102,000	170,000	60,000	51,000	3,000	2.5000	RBC 6	CRBC 6
1 1/4	1,200	135,000	218,000	70,000	61,000	3,000	3.0000	RBC 7	CRBC 7
1 1/4	1,100	175,000	272,000	98,000	70,000	3,000	3.2500	RBC 8	CRBC 8
1 1/4	1,000	221,000	352,000	127,000	79,000	3,000	3.7500	RBC 9	CRBC 9
1 1/4	900	272,000	441,000	159,000	88,000	3,000	4.2500	RBC 10	CRBC 10

Excessive clamping torque may cause shoulder K to dig into housing.

- ① 1/16 inch for sizes RBC 5 and larger.
- ② Torque may be doubled for completely dry threads.
- ③ Bearing Static Capacity provided for comparison only.

RBC Roller®

Heavy Stud (Hex Head)

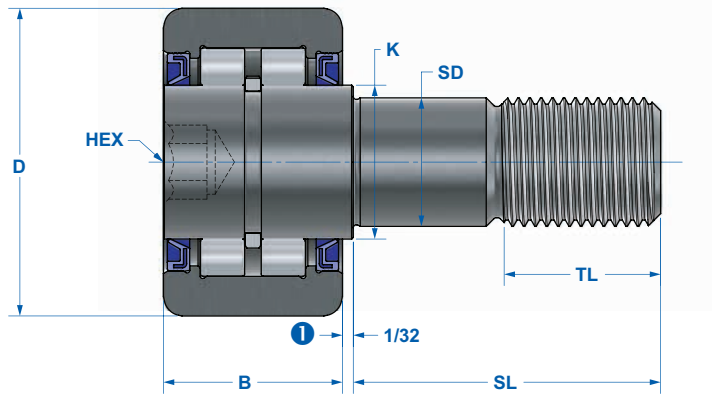

Series HRBC, CHRBC

PART NUMBER		ROLLER			STUD					APPROX. WEIGHT [lbs]
		D	B	CR	SD	SL	K	TL	Thread Class 2A	
		Outside Diameter + .000 - .001	Roller Width + .000 - .005	Crown Radius	Shank Diameter + .001 - .000	Shank Length	Shoulder Diameter	Eff. Thread Length		
HRBC 1 1/2	CHRBC 1 1/2	1.500	0.875	20	0.8750	1.500	1.000	0.750	7/8-14	0.62
HRBC 1 5/8	CHRBC 1 5/8	1.625	0.875	20	0.8750	1.500	1.000	0.750	7/8-14	0.70
HRBC 1 3/4	CHRBC 1 3/4	1.750	1.000	20	1.0000	1.750	1.186	0.875	1-14	0.98
HRBC 1 7/8	CHRBC 1 7/8	1.875	1.000	20	1.0000	1.750	1.186	0.875	1-14	1.08
HRBC 2	CHRBC 2	2.000	1.250	24	1.1250	2.000	1.375	1.000	1 1/8-12	1.53
HRBC 2 1/4	CHRBC 2 1/4	2.250	1.250	24	1.1250	2.000	1.375	1.000	1 1/8-12	1.83
HRBC 2 1/2	CHRBC 2 1/2	2.500	1.500	30	1.2500	2.250	1.435	1.125	1 1/4-12	2.59
HRBC 2 3/4	CHRBC 2 3/4	2.750	1.500	30	1.2500	2.250	1.435	1.125	1 1/4-12	3.03
HRBC 3	CHRBC 3	3.000	1.750	30	1.5000	2.500	1.750	1.250	1 1/2-12	4.31
HRBC 3 1/4	CHRBC 3 1/4	3.250	1.750	30	1.5000	2.500	1.750	1.250	1 1/2-12	4.92
HRBC 3 1/2	CHRBC 3 1/2	3.500	2.000	30	1.7500	2.750	2.000	1.375	1 3/4-12	3.73
HRBC 4	CHRBC 4	4.000	2.250	30	2.0000	3.500	2.500	1.500	2-12	10.21
HRBC 5	CHRBC 5	5.000	2.750	48	2.5000	5.062	3.125	2.562	2 1/2-12	20.82
HRBC 6	CHRBC 6	6.000	3.250	56	3.0000	6.000	3.750	3.000	3-12	34.60

All dimensions are in inches.

To specify RBC Roller® with lubrication holes, add OH suffix (example: HRBC 1 1/2 OH).

Seals can be removed for flow-through lubrication.

To specify RBC Roller® without seals, add NS suffix (example: HRBC 4 NS).

RBC Roller®

Heavy Stud (Hex Head)



Series HRBC, CHRBC

SOCKET HEAD WRENCH SIZE	SPEED LIMIT [rpm]	CAPACITIES				MOUNTING DATA		PART NUMBER	
		C	C ₀	Max. Allowable Load [lbf]	Track Capacity @ 40 Rc [lbf]	Max. Clamping Torque [in*lbf]	Housing Bore + .0005 - .0002		
		Dynamic Capacity [lbf]	Static Capacity [lbf]						
5/16	6,200	6,200	7,000	2,400	3,320	900	0.8750	HRBC 1 1/2	CHRBC 1 1/2
5/16	6,200	6,200	7,000	2,800	3,600	900	0.8750	HRBC 1 5/8	CHRBC 1 5/8
5/16	4,700	8,200	10,500	3,150	4,550	1,350	1.0000	HRBC 1 3/4	CHRBC 1 3/4
5/16	4,700	8,200	10,500	3,800	4,900	1,350	1.0000	HRBC 1 7/8	CHRBC 1 7/8
7/16	4,100	12,400	17,200	5,500	6,500	1,700	1.1250	HRBC 2	CHRBC 2
7/16	4,100	12,400	17,200	7,000	7,300	1,700	1.1250	HRBC 2 1/4	CHRBC 2 1/4
1/2	3,700	16,800	22,800	9,100	9,400	2,050	1.2500	HRBC 2 1/2	CHRBC 2 1/2
1/2	3,700	16,800	22,800	10,900	10,400	2,050	1.2500	HRBC 2 3/4	CHRBC 2 3/4
5/8	3,100	28,900	39,100	15,000	13,300	3,000	1.5000	HRBC 3	CHRBC 3
5/8	3,100	28,900	39,100	17,800	14,400	3,000	1.5000	HRBC 3 1/4	CHRBC 3 1/4
5/8	2,900	36,100	53,000	21,200	17,300	3,000	1.7500	HRBC 3 1/2	CHRBC 3 1/2
3/4	2,000	46,200	72,000	34,700	22,100	3,000	2.0000	HRBC 4	CHRBC 4
7/8	1,600	64,100	103,400	49,700	35,000	3,000	2.5000	HRBC 5	CHRBC 5
1	1,400	88,000	136,700	52,200	79,700	3,000	3.0000	HRBC 6	CHRBC 6

Excessive clamping torque may cause shoulder K to dig into housing.

- ① 1/16 inch for sizes HRBC 5 and larger.
- ② Torque may be doubled for completely dry threads.
- ③ Bearing Static Capacity provided for comparison only.

RBC Roller®

Long-Life Yoke Rollers

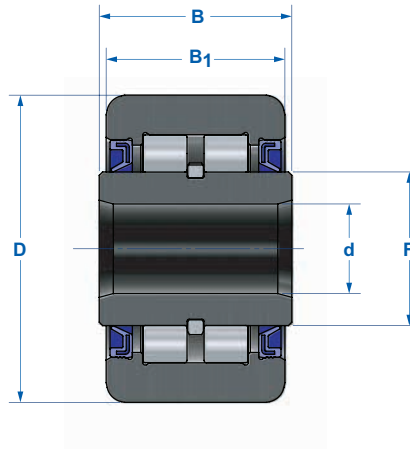

Series RBY, CRBY

PART NUMBER		ROLLER			INSIDE DIAMETER			B Overall Width +.005 -.010	F Shaft Shoulder (Ref)	APPROX. WEIGHT [lbs]
		D Outside Diameter +.000 -.001	B ₁ Roller Width +.000 -.005	CR Crown Radius	d					
					Nom.	Min.	Max.			
RBY 1	CRBY 1	1.000	0.625	12	5/16	0.3121	0.3127	0.6875	0.500	0.12
RBY 1 1/8	CRBY 1 1/8	1.125	0.625	12	5/16	0.3121	0.3127	0.6875	0.500	0.15
RBY 1 1/4	CRBY 1 1/4	1.250	0.750	14	3/8	0.3746	0.3752	0.8125	0.625	0.23
RBY 1 3/8	CRBY 1 3/8	1.375	0.750	14	3/8	0.3746	0.3752	0.8125	0.625	0.28
RBY 1 1/2	CRBY 1 1/2	1.500	0.875	20	7/16	0.4371	0.4377	0.9375	0.750	0.37
RBY 1 5/8	CRBY 1 5/8	1.625	0.875	20	7/16	0.4371	0.4377	0.9375	0.750	0.44
RBY 1 3/4	CRBY 1 3/4	1.750	1.000	20	1/2	0.4996	0.5002	1.0625	1.000	0.58
RBY 1 7/8	CRBY 1 7/8	1.875	1.000	20	1/2	0.4996	0.5002	1.0625	1.000	0.67
RBY 2	CRBY 2	2.000	1.250	24	5/8	0.6246	0.6252	1.3125	1.125	0.92
RBY 2 1/4	CRBY 2 1/4	2.250	1.250	24	5/8	0.6246	0.6252	1.3125	1.125	1.20
RBY 2 1/2	CRBY 2 1/2	2.500	1.500	30	3/4	0.7496	0.7502	1.5625	1.250	1.75
RBY 2 3/4	CRBY 2 3/4	2.750	1.500	30	3/4	0.7496	0.7502	1.5625	1.250	2.15
RBY 3	CRBY 3	3.000	1.750	30	1	0.9995	1.0001	1.8125	1.500	2.87
RBY 3 1/4	CRBY 3 1/4	3.250	1.750	30	1	0.9995	1.0001	1.8125	1.500	3.43
RBY 3 1/2	CRBY 3 1/2	3.500	2.000	30	1 1/8	1.1245	1.1251	2.0625	1.625	4.50
RBY 4	CRBY 4	4.000	2.250	30	1 1/4	1.2495	1.2501	2.3125	2.250	6.65
RBY 5	CRBY 5	5.000	2.750	48	1 3/4	1.7495	1.7501	2.8750	2.750	12.30
RBY 6	CRBY 6	6.000	3.250	56	2 1/4	2.2495	2.2501	3.3750	3.000	20.60
RBY 7	CRBY 7	7.000	3.750	60	2 3/4	2.7495	2.7501	3.8750	3.750	31.80
RBY 8	CRBY 8	8.000	4.250	40	3 1/4	3.2550	3.2560	4.5000	4.000	46.50
RBY 9	CRBY 9	9.000	4.750	40	3 3/4	3.7550	3.7560	5.0000	4.500	65.00
RBY 10	CRBY 10	10.000	5.250	40	4 1/4	4.2550	4.2560	5.5000	5.000	88.00

All dimensions are in inches.

To specify RBC Roller® with lubrication holes, add OH suffix (example: RBY 1 3/4 OH).

Seals can be removed for flow-through lubrication.

To specify RBC Roller® without seals, add NS suffix (example: RBY 3 1/2 NS).

RBC Roller®

Long-Life Yoke Rollers

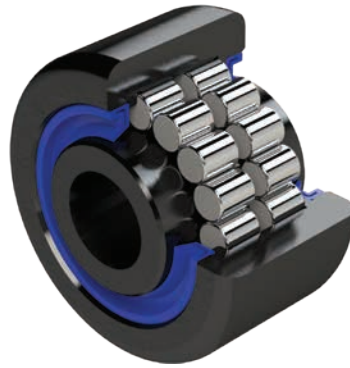

Series RBY, CRBY

SPEED LIMIT [rpm]	CAPACITIES				MOUNTING DATA				PART NUMBER	
	C	C ₀	Max. Allowable Load	Track Capacity @ 40 Rc	Transition Fit		Press Fit			
	Dynamic Capacity [lbf]	Static Capacity [lbf] ①			Max.	Min.	Max.	Min.		
9,400	3,000	3,200	1,400	1,660	0.3122	0.3118	0.3130	0.3126	RBY 1	CRBY 1
9,400	3,000	3,200	1,700	1,870	0.3122	0.3118	0.3130	0.3126	RBY 1 1/8	CRBY 1 1/8
7,500	4,100	4,300	1,500	2,440	0.3747	0.3743	0.3755	0.3751	RBY 1 1/4	CRBY 1 1/4
7,500	4,100	4,300	1,850	2,680	0.3747	0.3743	0.3755	0.3751	RBY 1 3/8	CRBY 1 3/8
6,200	6,200	7,000	2,400	3,320	0.4372	0.4368	0.4380	0.4376	RBY 1 1/2	CRBY 1 1/2
6,200	6,200	7,000	2,800	3,600	0.4372	0.4368	0.4380	0.4376	RBY 1 5/8	CRBY 1 5/8
4,700	8,200	10,500	3,150	4,550	0.4997	0.4993	0.5007	0.5003	RBY 1 3/4	CRBY 1 3/4
4,700	8,200	10,500	3,800	4,900	0.4997	0.4993	0.5007	0.5003	RBY 1 7/8	CRBY 1 7/8
4,100	12,400	17,200	5,500	6,500	0.6247	0.6243	0.6257	0.6253	RBY 2	CRBY 2
4,100	12,400	17,200	7,000	7,300	0.6247	0.6243	0.6257	0.6253	RBY 2 1/4	CRBY 2 1/4
3,700	16,800	22,800	9,100	9,400	0.7497	0.7493	0.7507	0.7503	RBY 2 1/2	CRBY 2 1/2
3,700	16,800	22,800	10,900	10,400	0.7497	0.7493	0.7507	0.7503	RBY 2 3/4	CRBY 2 3/4
3,100	28,900	39,100	15,000	13,300	0.9996	0.9991	1.0008	1.0003	RBY 3	CRBY 3
3,100	28,900	39,100	17,800	14,400	0.9996	0.9991	1.0008	1.0003	RBY 3 1/4	CRBY 3 1/4
2,900	36,100	53,000	21,200	17,300	1.1246	1.1241	1.1258	1.1253	RBY 3 1/2	CRBY 3 1/2
2,600	45,600	68,000	23,700	22,000	1.2496	1.2491	1.2508	1.2503	RBY 4	CRBY 4
2,000	71,000	110,000	43,700	35,000	1.7496	1.7491	1.7508	1.7503	RBY 5	CRBY 5
1,500	102,000	170,000	60,000	52,000	2.2496	2.2491	2.2508	2.2503	RBY 6	CRBY 6
1,200	135,600	218,000	70,000	61,000	2.7496	2.7491	2.7508	2.7503	RBY 7	CRBY 7
1,100	175,400	272,000	98,000	70,000	3.2550	3.2540	3.2570	3.2560	RBY 8	CRBY 8
1,000	221,000	352,000	127,000	79,000	3.7550	3.7540	3.7570	3.7560	RBY 9	CRBY 9
900	272,000	441,000	159,000	88,000	4.2550	4.2540	4.2570	4.2560	RBY 10	CRBY 10

① Bearing Static Capacity provided for comparison only.

HexLube® Universal Cam Followers

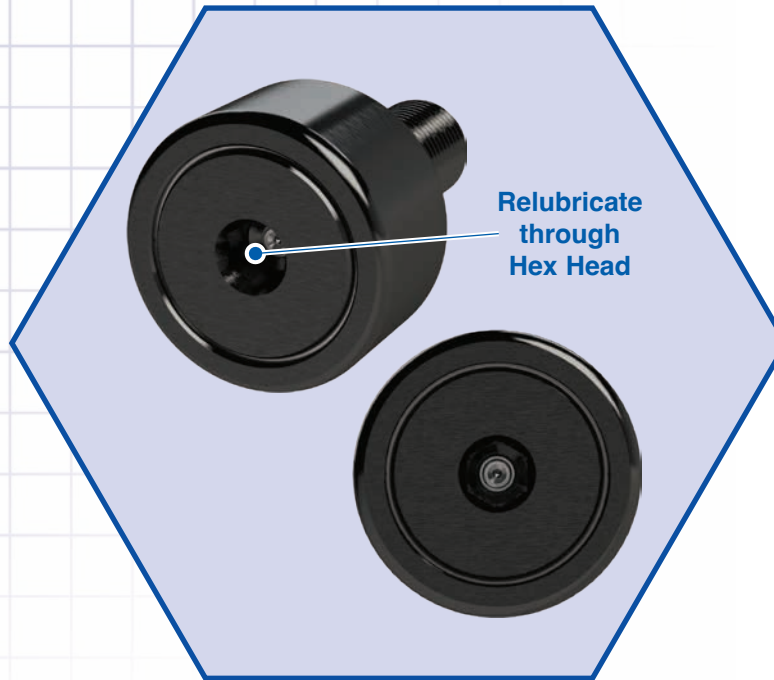

RBC Bearings® offers **HexLube®** Universal line of cam followers, designed with a unique lubricating feature. The **RBC HexLube® Universal Cam Follower** allows for relubrication through the hexagonal head of the cam follower, making relubrication in tight spots possible. In addition, the universal design of the **RBC HexLube® Cam Follower** can eliminate the need to stock both screwdriver slot and unsealed cam followers. RBC expects that most customers can reduce their inventory on stud type cam followers by 50% using this new universal line. The complete line is available in sizes with an outside diameter from 3/4 inch to 7 inches.

The **RBC HexLube® Universal Cam Follower** design provides the easiest and fastest way to relubricate cam followers in hard to reach places or in applications where stud access is limited. A cam follower that is properly maintained and lubricated will last longer than a cam follower that is neglected due to the difficulties posed by relubrication.

Companies looking to sharply reduce their inventory levels will recognize the value of RBC's universal design of the **HexLube® Cam Follower**. By stocking the **RBC HexLube®** line, companies will no longer need to carry inventories of either screwdriver slot or unsealed cam followers.

The entire line of **RBC HexLube® Universal Cam Followers** is dimensionally interchangeable with other needle bearing cam followers. The **RBC HexLube® Universal Cam Follower** is available in both eccentric and crowned versions. Both standard studs and heavy studs are available as well.

RBC HexLube® Universal Cam Followers are designed for applications such as automation and production equipment, bottling and canning, printing machinery, material handling, construction equipment, transfer lines, food processing, and packaging equipment.

HexLube®

HexLube® Universal Cam Followers

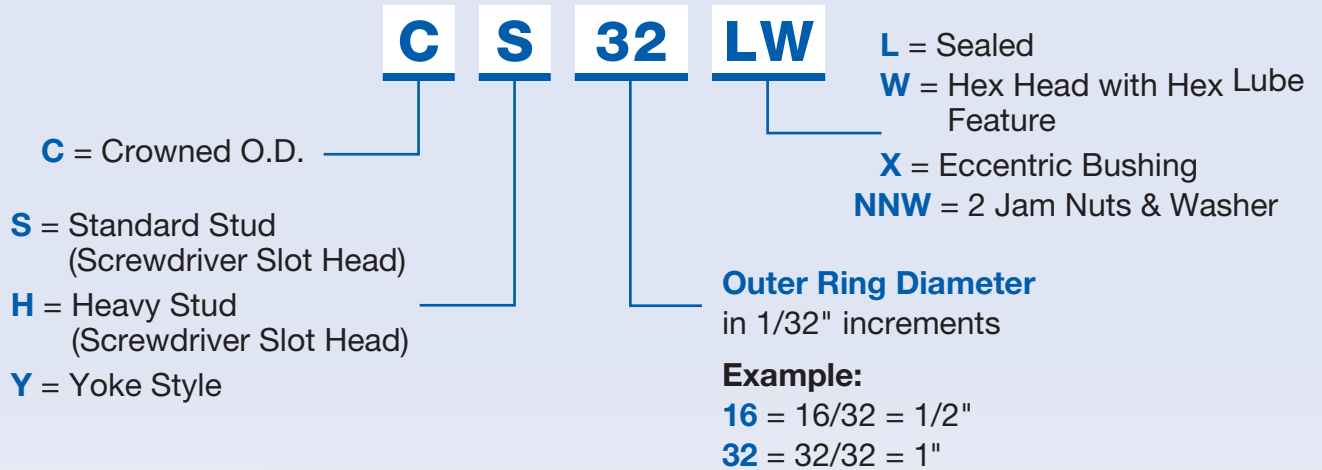

RBC developed the Universal Cam Follower product line to replace standard cam followers, and delivered two obvious benefits. First, it is possible to relubricate the hex head cam follower through the head. The hex head feature is the preferred mounting method for stud-type cam followers, and now it can be relubricated in tight spots or when stud access is restricted. Second, the **HexLube®** can eliminate the need to stock both screwdriver slot and unsealed cam followers. Your inventory can be reduced significantly!!

The **HexLube® Cam Follower** allows lubrication through the head of the cam follower, eliminating the need to stock the screwdriver slot series. Also eliminated from the line were all unsealed cam followers. Reducing your inventory by this large amount results in real savings. The end result is a product line with just 186 line items!

RBC HexLube®

Savings at Every Turn!

- ✓ Significant inventory reduction
- ✓ Allows Relubrication in tight spots or when stud access is limited
- ✓ HexLube® Universal Cam Follower can eliminate the need to stock screwdriver slots or unsealed cam followers
- ✓ Sizes from 3/4" to 7" O.D.
- ✓ Eccentric and Crowned versions
- ✓ Available in Standard Stud and Heavy Stud



Cam Followers

Standard Stud

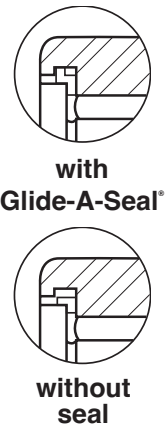
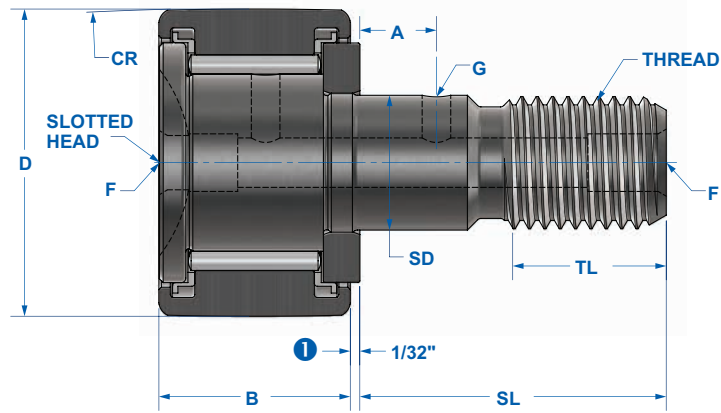

Series S, S-L

Nominal Size	PART NUMBER			ROLLER		STUD				APPROX. WEIGHT [lbs]
	Slotted Head	Slotted Head & Sealed	Hexlube® Socket Head & Sealed	D	B	SD	SL	TL	Thread Class 2A	
				Outside Diameter + .000 - .001	Roller Width + .000 - .005	Shank Diameter + .001 - .000	Shank Length	Eff. Thread Length		
1/2	S 16	S 16 L	S 16 LW	0.5000	0.375	0.1900	0.625	0.250	10-32	0.02
9/16	S 18	S 18 L	S 18 LW	0.5625	0.375	0.1900	0.625	0.250	10-32	0.03
5/8	S 20	S 20 L	S 20 LW	0.6250	0.438	0.2500	0.750	0.313	1/4-28	0.05
11/16	S 22	S 22 L	S 22 LW	0.6875	0.438	0.2500	0.750	0.313	1/4-28	0.05
3/4	S 24	S 24 L	S 24 LW	0.7500	0.500	0.3750	0.875	0.375	3/8-24	0.08
7/8	S 28	S 28 L	S 28 LW	0.8750	0.500	0.3750	0.875	0.375	3/8-24	0.10
1	S 32	S 32 L	S 32 LW	1.0000	0.625	0.4375	1.000	0.500	7/16-20	0.16
1 1/8	S 36	S 36 L	S 36 LW	1.1250	0.625	0.4375	1.000	0.500	7/16-20	0.19
1 1/4	S 40	S 40 L	S 40 LW	1.2500	0.750	0.5000	1.250	0.625	1/2-20	0.29
1 3/8	S 44	S 44 L	S 44 LW	1.3750	0.750	0.5000	1.250	0.625	1/2-20	0.34
1 1/2	S 48	S 48 L	S 48 LW	1.5000	0.875	0.6250	1.500	0.750	5/8-18	0.51
1 5/8	S 52	S 52 L	S 52 LW	1.6250	0.875	0.6250	1.500	0.750	5/8-18	0.61
1 3/4	S 56	S 56 L	S 56 LW	1.7500	1.000	0.7500	1.750	0.875	3/4-16	0.83
1 7/8	S 60	S 60 L	S 60 LW	1.8750	1.000	0.7500	1.750	0.875	3/4-16	0.92
2	S 64	S 64 L	S 64 LW	2.0000	1.250	0.8750	2.000	1.000	7/8-14	1.32
2 1/4	S 72	S 72 L	S 72 LW	2.2500	1.250	0.8750	2.000	1.000	7/8-14	1.61
2 1/2	S 80	S 80 L	S 80 LW	2.5000	1.500	1.0000	2.250	1.125	1-14	2.48
2 3/4	S 88	S 88 L	S 88 LW	2.7500	1.500	1.0000	2.250	1.125	1-14	2.83
3	S 96	S 96 L	S 96 LW	3.0000	1.750	1.2500	2.500	1.250	1 1/4-12	4.04
3 1/4	S 104	S 104 L	S 104 LW	3.2500	1.750	1.2500	2.500	1.250	1 1/4-12	4.75
3 1/2	S 112	S 112 L	S 112 LW	3.5000	2.000	1.3750	2.750	1.375	1 3/8-12	6.22
4	S 128	S 128 L	S 128 LW	4.0000	2.250	1.5000	3.500	1.500	1 1/2-12	7.44
5	-	-	S 160 LW	5.0000	2.750	2.0000	5.062	2.562	2-12	18.70
6	-	-	S 192 LW	6.0000	3.250	2.5000	6.000	3.000	2 1/2-12	32.90
7	-	-	S 224 LW	7.0000	3.750	3.0000	7.688	4.125	3-12	53.90

All dimensions are in inches.

① 1/16" for sizes S 160 LW and larger.

HexLube® Universal Cam Followers

Standard Stud

Relubricate through Hex Head



Series S-LW

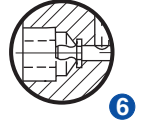
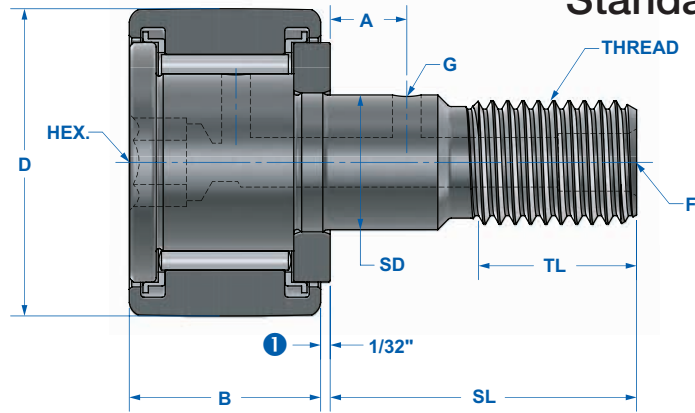

					CAPACITIES				MOUNTING DATA			BASIC NUMBER
F	A	G	SOCKET HEAD WRENCH SIZE	SPEED LIMIT [rpm]	C	Co	Max. Allow. Load	Track Capacity @ 40 Rc	Max. Clamping Torque	Hsg. Bore	Min. Boss Dia.	
Lube Fitting ③	Loc.	Dia.			[lbf]	[lbf] ⑤	[lbf]	[lbf]	[in*lbf] ④	+ .0005 - .0000		
②	-	-	1/8	5,000	770	1,100	310	430	7.5	0.1900	0.29	-16
②	-	-	1/8	5,000	770	1,100	310	480	7.5	0.1900	0.29	-18
②	-	-	1/8	5,000	1,060	1,700	610	770	20	0.2500	0.36	-20
②	-	-	1/8	5,000	1,060	1,700	610	850	20	0.2500	0.36	-22
3/16	0.250	0.093	3/16	5,000	1,800	3,100	1,840	880	55	0.3750	0.50	-24
3/16	0.250	0.093	3/16	5,000	1,800	3,100	1,840	1,030	55	0.3750	0.50	-28
3/16	0.250	0.093	1/4	4,500	2,300	4,800	2,390	1,690	150	0.4375	0.64	-32
3/16	0.250	0.093	1/4	4,500	2,300	4,800	2,390	1,900	150	0.4375	0.64	-36
3/16	0.312	0.093	1/4	3,900	4,200	6,600	3,000	2,440	200	0.5000	0.76	-40
3/16	0.312	0.093	1/4	3,900	4,200	6,600	3,000	2,680	200	0.5000	0.76	-44
3/16	0.375	0.093	5/16	3,100	5,000	8,800	5,100	3,320	390	0.6250	0.89	-48
3/16	0.375	0.093	5/16	3,100	5,000	8,800	5,100	3,600	390	0.6250	0.89	-52
3/16	0.437	0.125	5/16	2,600	6,400	12,400	7,800	4,550	750	0.7500	1.05	-56
3/16	0.437	0.125	5/16	2,600	6,400	12,400	7,800	4,900	750	0.7500	1.05	-60
3/16	0.500	0.125	7/16	2,200	9,600	16,700	10,000	6,500	900	0.8750	1.20	-64
3/16	0.500	0.125	7/16	2,200	9,600	16,700	10,000	7,300	900	0.8750	1.20	-72
3/16	0.562	0.125	1/2	2,000	12,800	25,400	12,500	9,400	1,300	1.0000	1.31	-80
3/16	0.562	0.125	1/2	2,000	12,800	25,400	12,500	10,400	1,300	1.0000	1.31	-88
1/4	0.625	0.187	5/8	1,600	17,000	40,000	21,000	13,300	2,000	1.2500	2.00	-96
1/4	0.625	0.187	5/8	1,600	17,000	40,000	21,000	14,400	2,000	1.2500	2.00	-104
1/4	0.687	0.187	5/8	1,400	24,300	54,600	24,750	17,300	2,500	1.3750	2.39	-112
1/4	0.750	0.187	3/4	1,300	30,000	73,100	28,500	22,000	3,000	1.5000	2.62	-128
1/4 NPT	0.875	0.187	7/8	1,000	47,200	102,000	55,000	35,000	3,000	2.0000	3.50	-160
1/4 NPT	1.000	0.187	1	800	62,900	165,500	90,000	52,000	3,000	2.5000	4.50	-192
1/4 NPT	1.250	0.187	1 1/4	700	79,400	237,800	139,000	71,000	3,000	3.0000	5.25	-224

② Sizes S 16 through S 22 and S 16 L through S 22 L have a 1/8" hole at the flange end only.
 ③ Sizes S 16 LW through S 22 LW cannot be relubricated.
 ④ Torque may be doubled for completely dry threads.

⑤ Bearing Static Capacity provided for comparison only.
 ⑥ HexLube® Cam Followers can be regreased through the hex head using a Lincoln #5803 or Alemite #B6783 needle nozzle adapter.

Crowned Cam Followers

Standard Stud

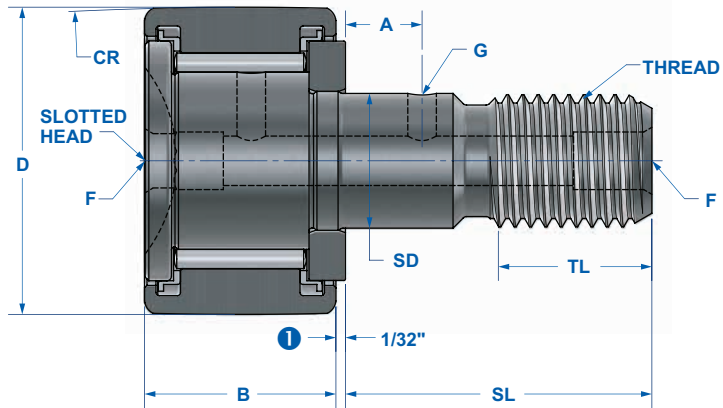

with
Glide-A-Seal®

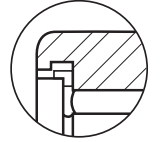

without
seal

Series CS-L

Nominal Size	PART NUMBER		ROLLER			STUD				APPROX. WEIGHT [lbs]
	Slotted Head & Sealed	Hexlube® Socket Head & Sealed	D Outside Diameter + .000 - .001	B Roller Width + .000 - .005	CR Crown Radius	SD Shank Diameter + .001 - .000	SL Shank Length	TL Eff. Thread Length	Thread Class 2A	
1/2	CS 16 L	CS 16 LW	0.5000	0.375	7	0.1900	0.625	0.250	10-32	0.02
9/16	CS 18 L	CS 18 LW	0.5625	0.375	7	0.1900	0.625	0.250	10-32	0.03
5/8	CS 20 L	CS 20 LW	0.6250	0.438	8	0.2500	0.750	0.313	1/4-28	0.05
11/16	CS 22 L	CS 22 LW	0.6875	0.438	8	0.2500	0.750	0.313	1/4-28	0.05
3/4	CS 24 L	CS 24 LW	0.7500	0.500	10	0.3750	0.875	0.375	3/8-24	0.08
7/8	CS 28 L	CS 28 LW	0.8750	0.500	10	0.3750	0.875	0.375	3/8-24	0.10
1	CS 32 L	CS 32 LW	1.0000	0.625	12	0.4375	1.000	0.500	7/16-20	0.16
1 1/8	CS 36 L	CS 36 LW	1.1250	0.625	12	0.4375	1.000	0.500	7/16-20	0.19
1 1/4	CS 40 L	CS 40 LW	1.2500	0.750	14	0.5000	1.250	0.625	1/2-20	0.29
1 3/8	CS 44 L	CS 44 LW	1.3750	0.750	14	0.5000	1.250	0.625	1/2-20	0.34
1 1/2	CS 48 L	CS 48 LW	1.5000	0.875	20	0.6250	1.500	0.750	5/8-18	0.51
1 5/8	CS 52 L	CS 52 LW	1.6250	0.875	20	0.6250	1.500	0.750	5/8-18	0.61
1 3/4	CS 56 L	CS 56 LW	1.7500	1.000	20	0.7500	1.750	0.875	3/4-16	0.83
1 7/8	CS 60 L	CS 60 LW	1.8750	1.000	20	0.7500	1.750	0.875	3/4-16	0.92
2	CS 64 L	CS 64 LW	2.0000	1.250	24	0.8750	2.000	1.000	7/8-14	1.32
2 1/4	CS 72 L	CS 72 LW	2.2500	1.250	24	0.8750	2.000	1.000	7/8-14	1.61
2 1/2	CS 80 L	CS 80 LW	2.5000	1.500	30	1.0000	2.250	1.125	1-14	2.48
2 3/4	CS 88 L	CS 88 LW	2.7500	1.500	30	1.0000	2.250	1.125	1-14	2.83
3	CS 96 L	CS 96 LW	3.0000	1.750	30	1.2500	2.500	1.250	1 1/4-12	4.04
3 1/4	CS 104 L	CS 104 LW	3.2500	1.750	30	1.2500	2.500	1.250	1 1/4-12	4.75
3 1/2	CS 112 L	CS 112 LW	3.5000	2.000	30	1.3750	2.750	1.375	1 3/8-12	6.22
4	CS 128 L	CS 128 LW	4.0000	2.250	30	1.5000	3.500	1.500	1 1/2-12	7.44
5	-	CS 160 LW	5.0000	2.750	48	2.0000	5.062	2.562	2-12	18.70
6	-	CS 192 LW	6.0000	3.250	56	2.5000	6.000	3.000	2 1/2-12	32.90
7	-	CS 224 LW	7.0000	3.750	60	3.0000	7.688	4.125	3-12	53.90

All dimensions are in inches.

① 1/16" for sizes CS 160 LW and larger.

HexLube® Universal Cam Followers

Standard Stud

Relubricate through Hex Head



Series CS-LW

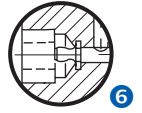
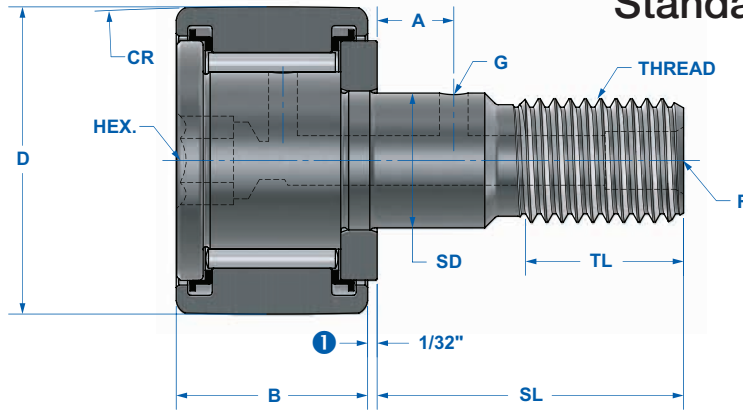

					CAPACITIES				MOUNTING DATA			BASIC NUMBER
F	A	G	SOCKET HEAD WRENCH SIZE	SPEED LIMIT [rpm]	C	C ₀		Track Capacity @ 40 Rc	Max. Clamping Torque	Hsg. Bore + .0005 - .0000	Min. Boss Dia.	
Lube Fitting ③	Loc.	Dia.			Dynamic Capacity [lbf]	Static Capacity [lbf] ⑤	Max. Allow. Load [lbf]					
②	-	-	1/8	5,000	770	1,100	310	430	7.5	0.1900	0.29	-16
②	-	-	1/8	5,000	770	1,100	310	480	7.5	0.1900	0.29	-18
②	-	-	1/8	5,000	1,060	1,700	610	770	20	0.2500	0.36	-20
②	-	-	1/8	5,000	1,060	1,700	610	850	20	0.2500	0.36	-22
3/16	0.250	0.093	3/16	5,000	1,800	3,100	1,840	880	55	0.3750	0.50	-24
3/16	0.250	0.093	3/16	5,000	1,800	3,100	1,840	1,030	55	0.3750	0.50	-28
3/16	0.250	0.093	1/4	4,500	2,300	4,800	2,390	1,690	150	0.4375	0.64	-32
3/16	0.250	0.093	1/4	4,500	2,300	4,800	2,390	1,900	150	0.4375	0.64	-36
3/16	0.312	0.093	1/4	3,900	4,200	6,600	3,000	2,440	200	0.5000	0.76	-40
3/16	0.312	0.093	1/4	3,900	4,200	6,600	3,000	2,680	200	0.5000	0.76	-44
3/16	0.375	0.093	5/16	3,100	5,000	8,800	5,100	3,320	390	0.6250	0.89	-48
3/16	0.375	0.093	5/16	3,100	5,000	8,800	5,100	3,600	390	0.6250	0.89	-52
3/16	0.437	0.125	5/16	2,600	6,400	12,400	7,800	4,550	750	0.7500	1.05	-56
3/16	0.437	0.125	5/16	2,600	6,400	12,400	7,800	4,900	750	0.7500	1.05	-60
3/16	0.500	0.125	7/16	2,200	9,600	16,700	10,000	6,500	900	0.8750	1.20	-64
3/16	0.500	0.125	7/16	2,200	9,600	16,700	10,000	7,300	900	0.8750	1.20	-72
3/16	0.562	0.125	1/2	2,000	12,800	25,400	12,500	9,400	1,300	1.0000	1.31	-80
3/16	0.562	0.125	1/2	2,000	12,800	25,400	12,500	10,400	1,300	1.0000	1.31	-88
1/4	0.625	0.187	5/8	1,600	17,000	40,000	21,000	13,300	2,000	1.2500	2.00	-96
1/4	0.625	0.187	5/8	1,600	17,000	40,000	21,000	14,400	2,000	1.2500	2.00	-104
1/4	0.687	0.187	5/8	1,400	24,300	54,600	24,750	17,300	2,500	1.3750	2.39	-112
1/4	0.750	0.187	3/4	1,300	30,000	73,100	28,500	22,000	3,000	1.5000	2.62	-128
1/4 NPT	0.875	0.187	7/8	1,000	47,200	102,000	55,000	35,000	3,000	2.0000	3.50	-160
1/4 NPT	1.000	0.187	1	800	62,900	165,500	90,000	52,000	3,000	2.5000	4.50	-192
1/4 NPT	1.250	0.187	1 1/4	700	79,400	237,800	139,000	71,000	3,000	3.0000	5.25	-224

② Sizes CS 16 through CS 22 and CS 16 L through CS 22 L have a 1/8" hole at the flange end only.

③ Sizes CS 16 LW through CS 22 LW cannot be relubricated.

④ Torque may be doubled for completely dry threads.

⑤ Bearing Static Capacity provided for comparison only.

⑥ HexLube® Cam Followers can be regreased through the hex head using a Lincoln #5803 or Alemite #B6783 needle nozzle adapter.

CamCentric™ Adjustable Cam Followers

Cylindrical & Crowned O.D.

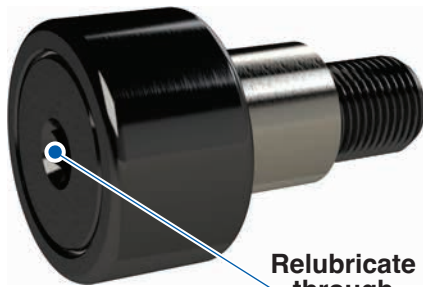

Relubricate through Hex Head

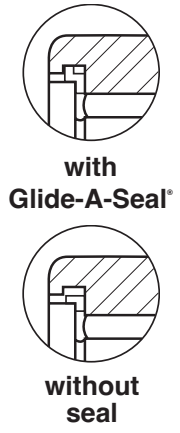
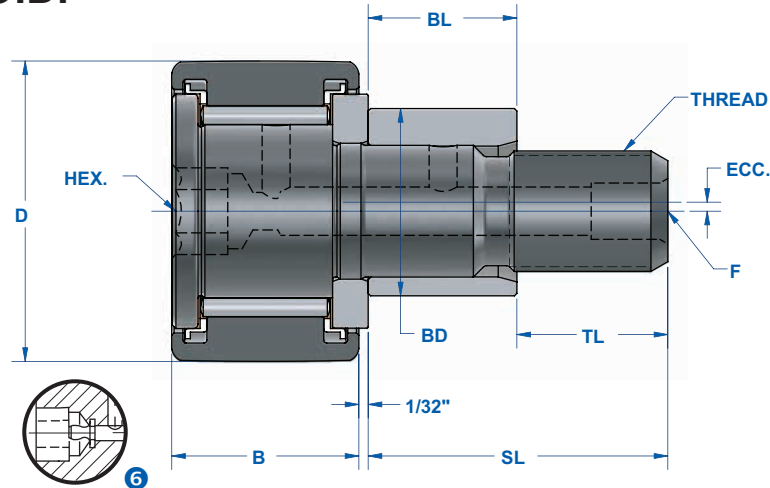

Series S-LWX

Nominal Size	PART NUMBER		ROLLER			STUD					
	Cylindrical O.D.	Crowned O.D.	D	B	CR	BD	BL	ECC	SL	TL	Thread Class 2A
			Outside Diameter	Roller Width	Crown Radius				Eccentricity	Shank Length	
1/2	S 16 LWX	CS 16 LWX	0.5000 +.000 -.001	0.375 +.000 -.005	7	0.250 +.000 -.002	0.375 +.000 -.010	0.010	0.625	0.250	10-32
9/16	S 18 LWX	CS 18 LWX	0.5625	0.375	7	0.250	0.375	0.010	0.625	0.250	10-32
5/8	S 20 LWX	CS 20 LWX	0.6250	0.438	8	0.375	0.437	0.015	0.750	0.312	1/4-28
11/16	S 22 LWX	CS 22 LWX	0.6875	0.438	8	0.375	0.437	0.015	0.750	0.312	1/4-28
3/4	S 24 LWX	CS 24 LWX	0.7500	0.500	10	0.500	0.500	0.015	0.875	0.375	3/8-24
7/8	S 28 LWX	CS 28 LWX	0.8750	0.500	10	0.500	0.500	0.015	0.875	0.375	3/8-24
1	S 32 LWX	CS 32 LWX	1.0000	0.625	12	0.625	0.500	0.030	1.000	0.500	7/16-20
1 1/8	S 36 LWX	CS 36 LWX	1.1250	0.625	12	0.625	0.500	0.030	1.000	0.500	7/16-20
1 1/4	S 40 LWX	CS 40 LWX	1.2500	0.750	14	0.687	0.625	0.030	1.250	0.625	1/2-20
1 3/8	S 44 LWX	CS 44 LWX	1.3750	0.750	14	0.687	0.625	0.030	1.250	0.625	1/2-20
1 1/2	S 48 LWX	CS 48 LWX	1.5000	0.875	20	0.875	0.750	0.030	1.500	0.750	5/8-18
1 5/8	S 52 LWX	CS 52 LWX	1.6250	0.875	20	0.875	0.750	0.030	1.500	0.750	5/8-18
1 3/4	S 56 LWX	CS 56 LWX	1.7500	1.000	20	1.000	0.875	0.030	1.750	0.875	3/4-16
1 7/8	S 60 LWX	CS 60 LWX	1.8750	1.000	20	1.000	0.875	0.030	1.750	0.875	3/4-16
2	S 64 LWX	CS 64 LWX	2.0000	1.250	24	1.187	1.000	0.030	2.000	1.000	7/8-14
2 1/4	S 72 LWX	CS 72 LWX	2.2500	1.250	24	1.187	1.000	0.030	2.000	1.000	7/8-14
2 1/2	S 80 LWX	CS 80 LWX	2.5000	1.500	30	1.375	1.125	0.030	2.250	1.125	1-14
2 3/4	S 88 LWX	CS 88 LWX	2.7500	1.500	30	1.375	1.125	0.030	2.250	1.125	1-14
3	S 96 LWX	CS 96 LWX	3.0000	1.750	30	1.750	1.250	0.060	2.500	1.250	1 1/4-12
3 1/4	S 104 LWX	CS 104 LWX	3.2500	1.750	30	1.750	1.250	0.060	2.500	1.250	1 1/4-12
3 1/2	S 112 LWX	CS 112 LWX	3.5000	2.000	30	1.812	1.375	0.060	2.750	1.375	1 3/8-12
4	S 128 LWX	CS 128 LWX	4.0000	2.250	30	2.000	2.000	0.060	3.500	1.500	1 1/2-12

All dimensions are in inches.

Do not clamp eccentric bushing.

Eccentric bushing press fitted and not heat treated to permit dowel or set screw engagement.

① For positive clamping action use a housing thickness tolerance of +0.010/-0.000 inches.

CamCentric™ Adjustable Cam Followers

Cylindrical & Crowned O.D

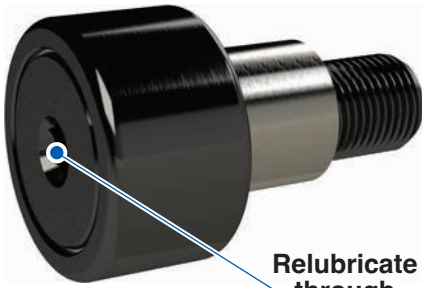

Relubricate through Hex Head

Series CS-LWX

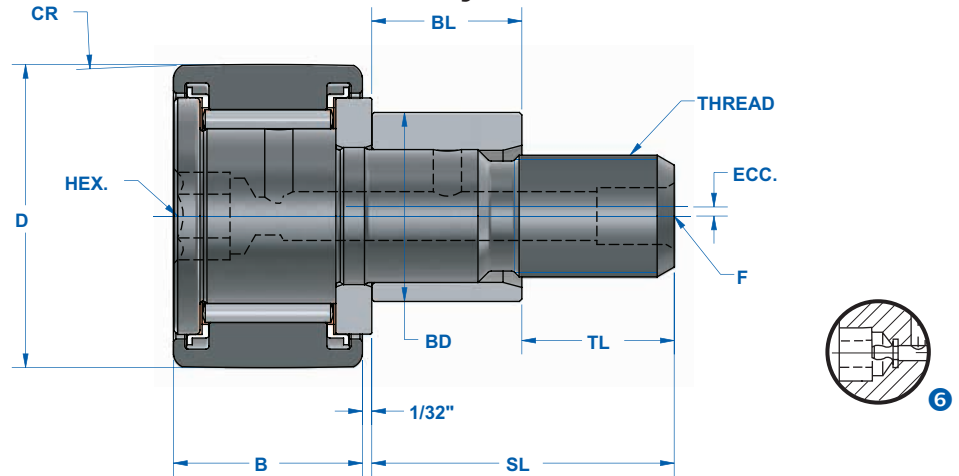

APPROX. WEIGHT [lbs]	F Lube Fitting	SOCKET HEAD WRENCH SIZE	SPEED LIMIT [rpm]	CAPACITIES				MOUNTING DATA		BASIC NUMBER
				C Dynamic Capacity [lbf]	C ₀ Static Capacity [lbf] ⁴	Max. Allow. Load [lbf]	Track Capacity @ 40 Rc [lbf]	Max. Clamping Torque [in*lb] ³	Hsg. Bore + .002 + .001	
0.025	2	1/8	5,000	770	1,100	310	430	7.5	0.250	-16
0.033	2	1/8	5,000	770	1,100	310	480	7.5	0.250	-18
0.056	2	1/8	5,000	1,060	1,700	610	770	20	0.375	-20
0.059	2	1/8	5,000	1,060	1,700	610	850	20	0.375	-22
0.088	3/16	3/16	5,000	1,800	3,100	1,840	880	55	0.500	-24
0.11	3/16	3/16	5,000	1,800	3,100	1,840	1,030	55	0.500	-28
0.18	3/16	1/4	4,500	2,300	4,800	2,390	1,690	150	0.625	-32
0.21	3/16	1/4	4,500	2,300	4,800	2,390	1,900	150	0.625	-36
0.32	3/16	1/4	3,900	4,200	6,600	3,000	2,440	200	0.687	-40
0.37	3/16	1/4	3,900	4,200	6,600	3,000	2,680	200	0.687	-44
0.57	3/16	5/16	3,100	5,000	8,800	5,100	3,320	390	0.875	-48
0.67	3/16	5/16	3,100	5,000	8,800	5,100	3,600	390	0.875	-52
0.92	3/16	5/16	2,600	6,400	12,400	7,800	4,550	750	1.000	-56
1.01	3/16	5/16	2,600	6,400	12,400	7,800	4,900	750	1.000	-60
1.46	3/16	7/16	2,200	9,600	16,700	10,000	6,500	900	1.187	-64
1.75	3/16	7/16	2,200	9,600	16,700	10,000	7,300	900	1.187	-72
2.70	3/16	1/2	2,000	12,800	25,400	12,500	9,400	1,300	1.375	-80
3.05	3/16	1/2	2,000	12,800	25,400	12,500	10,400	1,300	1.375	-88
4.46	1/4	5/8	1,600	17,000	40,000	21,000	13,300	2,000	1.750	-96
5.17	1/4	5/8	1,600	17,000	40,000	21,000	14,400	2,000	1.750	-104
6.65	1/4	5/8	1,400	24,300	54,600	24,750	17,300	2,500	1.812	-112
8.22	1/4	3/4	1,300	30,000	73,100	28,500	22,000	3,000	2.000	-128

² Sizes S 16 LWX through S 22 LWX and CS 16 LWX through CS 22 LWX cannot be relubricated.
³ Torque may be doubled for completely dry threads.
⁴ Bearing Static Capacity provided for comparison only.
⁶ HexLube® Cam Followers can be regreased through the hex head using a Lincoln #5803 or Alemite #B6783 needle nozzle adapter.

Cam Followers

Heavy Stud

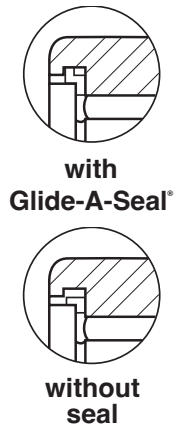
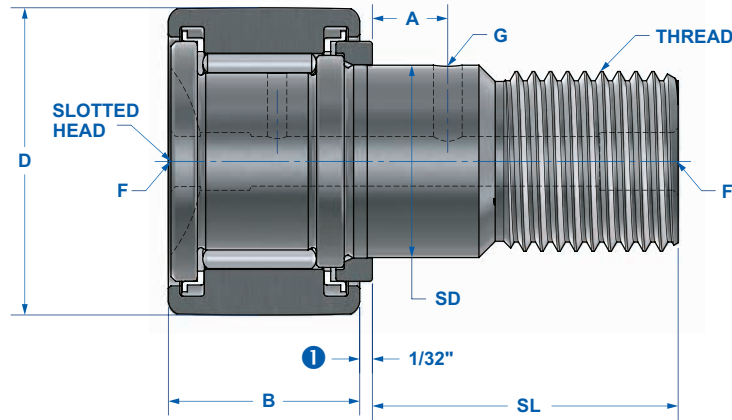

Series H, H-L

Nominal Size	PART NUMBER			ROLLER		STUD				APPROX. WEIGHT [lbs]
	Slotted Head	Slotted Head & Sealed	Hexlube [®] Socket Head & Sealed	D	B	SD	SL	TL	Thread Class 2A	
				Outside Diameter	Roller Width	Shank Diameter	Shank Length	Eff. Thread Length		
1/2	H 16	H 16 L	H 16 LW	+ .000 - .001	+ .000 - .005	+ .001 - .000	0.625	0.250	1/4-28	0.03
9/16	H 18	H 18 L	H 18 LW				0.625	0.250	1/4-28	0.03
5/8	H 20	H 20 L	H 20 LW				0.750	0.312	5/16-24	0.06
11/16	H 22	H 22 L	H 22 LW				0.750	0.312	5/16-24	0.07
3/4	H 24	H 24 L	H 24 LW				0.875	0.375	7/16-20	0.08
7/8	H 28	H 28 L	H 28 LW				0.875	0.375	7/16-20	0.12
1	H 32	H 32 L	H 32 LW				1.000	0.500	5/8-18	0.20
1 1/8	H 36	H 36 L	H 36 LW				1.000	0.500	5/8-18	0.25
1 1/4	H 40	H 40 L	H 40 LW				1.250	0.625	3/4-16	0.38
1 3/8	H 44	H 44 L	H 44 LW				1.250	0.625	3/4-16	0.44
1 1/2	H 48	H 48 L	H 48 LW				1.500	0.750	7/8-14	0.63
1 5/8	H 52	H 52 L	H 52 LW				1.500	0.750	7/8-14	0.69
1 3/4	H 56	H 56 L	H 56 LW				1.750	0.875	1-14	0.98
1 7/8	H 60	H 60 L	H 60 LW				1.750	0.875	1-14	1.08
2	H 64	H 64 L	H 64 LW				2.000	1.000	1 1/8-12	1.55
2 1/4	H 72	H 72 L	H 72 LW				2.000	1.000	1 1/8-12	1.90
2 1/2	H 80	H 80 L	H 80 LW				2.250	1.125	1 1/4-12	2.70
2 3/4	H 88	H 88 L	H 88 LW				2.250	1.125	1 1/4-12	3.14
3	H 96	H 96 L	H 96 LW				2.500	1.250	1 1/2-12	4.42
3 1/4	H 104	H 104 L	H 104 LW				2.500	1.250	1 1/2-12	5.15
3 1/2	H 112	H 112 L	H 112 LW				2.750	1.375	1 3/4-12	6.95
4	H 128	H 128 L	H 128 LW				3.500	1.500	2-12	10.30
5	-	-	H 160 LW				5.062	2.562	2 1/2-12	21.40
6	-	-	H 192 LW				6.000	3.000	3-12	36.40
7	-	-	H 224 LW				7.688	4.125	3 1/2- 4	59.20

All dimensions are in inches.

① 1/16" for sizes H 160 LW and larger.

HexLube® Universal Cam Followers

Heavy Stud

Relubricate through Hex Head



Series H-LW

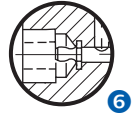
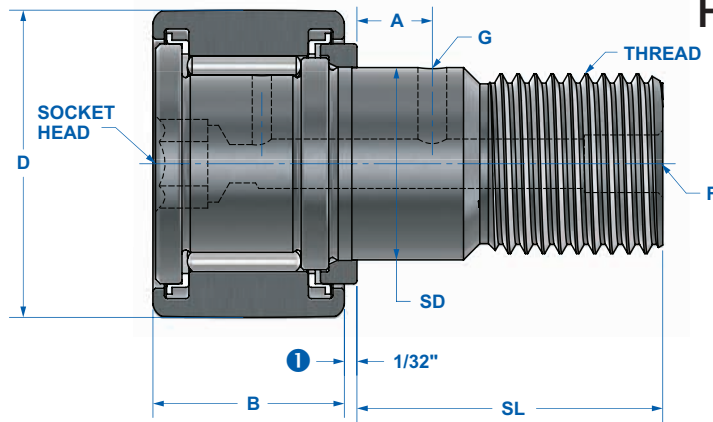

					CAPACITIES				MOUNTING DATA			BASIC NUMBER
F	A	G	SOCKET HEAD WRENCH SIZE	SPEED LIMIT [rpm]	C	C ₀		Track Capacity @ 40 Rc	Max. Clamping Torque [in*lb] 4	Hsg. Bore +.0005 -.0000	Min. Boss Dia.	
Lube Fitting 3	Loc.	Dia.			Dynamic Capacity [lbf]	Static Capacity [lbf] 5	Max. Allow. Load [lbf]					
2	-	-	1/8	5,000	770	1,590	700	430	20	0.2500	0.34	-16
2	-	-	1/8	5,000	770	1,590	700	480	20	0.2500	0.34	-18
2	-	-	1/8	5,000	970	2,500	1,200	770	55	0.3125	0.47	-20
2	-	-	1/8	5,000	970	2,500	1,200	850	55	0.3125	0.47	-22
3/16	0.250	0.093	3/16	5,000	1,800	4,150	2,920	1,070	150	0.4375	0.60	-24
3/16	0.250	0.093	3/16	5,000	1,800	4,150	2,920	1,240	150	0.4375	0.60	-28
3/16	0.250	0.093	1/4	4,500	2,300	6,150	4,100	1,690	390	0.6250	0.78	-32
3/16	0.250	0.093	1/4	4,500	2,300	6,150	4,100	1,900	390	0.6250	0.78	-36
3/16	0.312	0.093	1/4	3,900	4,000	8,500	5,800	2,440	750	0.7500	1.00	-40
3/16	0.312	0.093	1/4	3,900	4,000	8,500	5,800	2,680	750	0.7500	1.00	-44
3/16	0.375	0.093	5/16	3,100	4,900	11,300	7,900	3,320	900	0.8750	1.09	-48
3/16	0.375	0.093	5/16	3,100	4,900	11,300	7,900	3,600	900	0.8750	1.09	-52
3/16	0.437	0.125	5/16	2,600	6,400	15,850	11,400	4,550	1,350	1.0000	1.25	-56
3/16	0.437	0.125	5/16	2,600	6,400	15,850	11,400	4,900	1,350	1.0000	1.25	-60
3/16	0.500	0.125	7/16	2,200	9,600	21,200	16,700	6,500	1,700	1.1250	1.40	-64
3/16	0.500	0.125	7/16	2,200	9,600	21,200	16,700	7,300	1,700	1.1250	1.40	-72
3/16	0.562	0.125	1/2	2,000	12,900	33,000	25,400	9,400	2,050	1.2500	1.70	-80
3/16	0.562	0.125	1/2	2,000	12,900	33,000	25,400	10,400	2,050	1.2500	1.70	-88
1/4	0.625	0.187	5/8	1,600	17,000	49,900	36,600	13,300	3,000	1.5000	2.00	-96
1/4	0.625	0.187	5/8	1,600	17,000	49,900	36,600	14,400	3,000	1.5000	2.00	-104
1/4	0.687	0.187	5/8	1,400	24,300	63,250	51,000	17,300	3,000	1.7500	2.45	-112
1/4	0.750	0.187	3/4	1,300	25,600	89,550	68,000	22,000	3,000	2.0000	2.75	-128
1/4 NPT	0.875	0.187	7/8	1,000	44,900	136,000	99,000	35,000	3,000	2.5000	3.25	-160
1/4 NPT	1.000	0.187	1	800	61,600	161,300	160,000	52,000	3,000	3.0000	4.00	-192
1/4 NPT	1.250	0.187	1 1/4	700	79,400	237,800	217,000	71,000	3,000	3.5000	4.50	-224

2 Sizes H 16 through H 22 and H 16 L through H 22 L have a 1/8" hole at the flange end only.
 3 Sizes H 16 LW through H 22 LW cannot be relubricated.
 4 Torque may be doubled for completely dry threads.

5 Bearing Static Capacity provided for comparison only.
 6 HexLube® Cam Followers can be regreased through the hex head using a Lincoln #5803 or Alemite #B6783 needle nozzle adapter.

Crowned Cam Followers

Heavy Stud

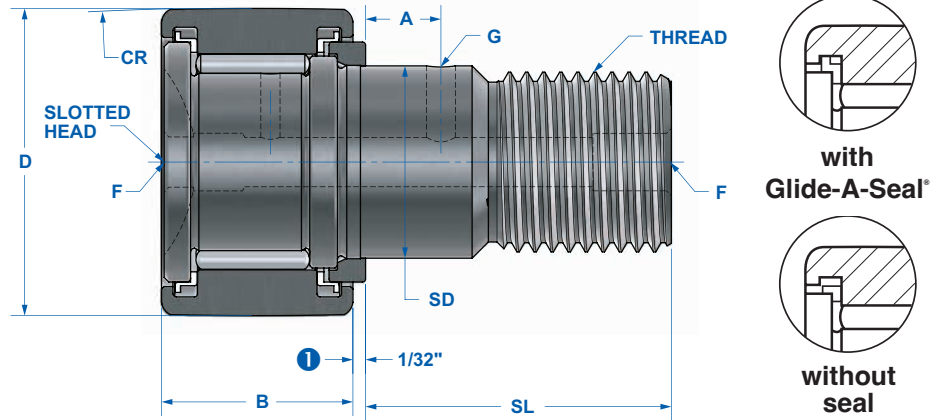

Series CH-L

Nominal Size	PART NUMBER		ROLLER			STUD				APPROX. WEIGHT [lbs]
	Slotted Head & Sealed	Hexlube® Socket Head & Sealed	D	B	CR	SD	SL	TL	Thread Class 2A	
			Outside Diameter + .000 - .001	Roller Width + .000 - .005	Crown Radius	Shank Diameter + .001 - .000	Shank Length	Eff. Thread Length		
1/2	CH 16 L	CH 16 LW	0.5000	0.375	7	0.2500	0.625	0.250	1/4-28	0.03
9/16	CH 18 L	CH 18 LW	0.5625	0.375	7	0.2500	0.625	0.250	1/4-28	0.03
5/8	CH 20 L	CH 20 LW	0.6250	0.438	8	0.3125	0.750	0.312	5/16-24	0.06
11/16	CH 22 L	CH 22 LW	0.6875	0.438	8	0.3125	0.750	0.312	5/16-24	0.07
3/4	CH 24 L	CH 24 LW	0.7500	0.500	10	0.4375	0.875	0.375	7/16-20	0.08
7/8	CH 28 L	CH 28 LW	0.8750	0.500	10	0.4375	0.875	0.375	7/16-20	0.12
1	CH 32 L	CH 32 LW	1.0000	0.625	12	0.6250	1.000	0.500	5/8-18	0.20
1 1/8	CH 36 L	CH 36 LW	1.1250	0.625	12	0.6250	1.000	0.500	5/8-18	0.25
1 1/4	CH 40 L	CH 40 LW	1.2500	0.750	14	0.7500	1.250	0.625	3/4-16	0.38
1 3/8	CH 44 L	CH 44 LW	1.3750	0.750	14	0.7500	1.250	0.625	3/4-16	0.44
1 1/2	CH 48 L	CH 48 LW	1.5000	0.875	20	0.8750	1.500	0.750	7/8-14	0.63
1 5/8	CH 52 L	CH 52 LW	1.6250	0.875	20	0.8750	1.500	0.750	7/8-14	0.69
1 3/4	CH 56 L	CH 56 LW	1.7500	1.000	20	1.0000	1.750	0.875	1-14	0.98
1 7/8	CH 60 L	CH 60 LW	1.8750	1.000	20	1.0000	1.750	0.875	1-14	1.08
2	CH 64 L	CH 64 LW	2.0000	1.250	24	1.1250	2.000	1.000	1 1/8-12	1.55
2 1/4	CH 72 L	CH 72 LW	2.2500	1.250	24	1.1250	2.000	1.000	1 1/8-12	1.90
2 1/2	CH 80 L	CH 80 LW	2.5000	1.500	30	1.2500	2.250	1.125	1 1/4-12	2.70
2 3/4	CH 88 L	CH 88 LW	2.7500	1.500	30	1.2500	2.250	1.125	1 1/4-12	3.14
3	CH 96 L	CH 96 LW	3.0000	1.750	30	1.5000	2.500	1.250	1 1/2-12	4.42
3 1/4	CH 104 L	CH 104 LW	3.2500	1.750	30	1.5000	2.500	1.250	1 1/2-12	5.15
3 1/2	CH 112 L	CH 112 LW	3.5000	2.000	30	1.7500	2.750	1.375	1 3/4-12	6.95
4	CH 128 L	CH 128 LW	4.0000	2.250	30	2.0000	3.500	1.500	2-12	10.30
5	-	CH 160 LW	5.0000	2.750	48	2.5000	5.062	2.562	2 1/2-12	21.40
6	-	CH 192 LW	6.0000	3.250	56	3.0000	6.000	3.000	3-12	36.40
7	-	CH 224 LW	7.0000	3.750	60	3.5000	7.688	4.125	3 1/2- 4	59.20

All dimensions are in inches.

① 1/16" for size CH 160 LW and larger.

HexLube® Universal Cam Followers

Heavy Stud

Relubricate through Hex Head



Series CH-LW

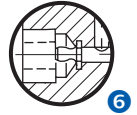
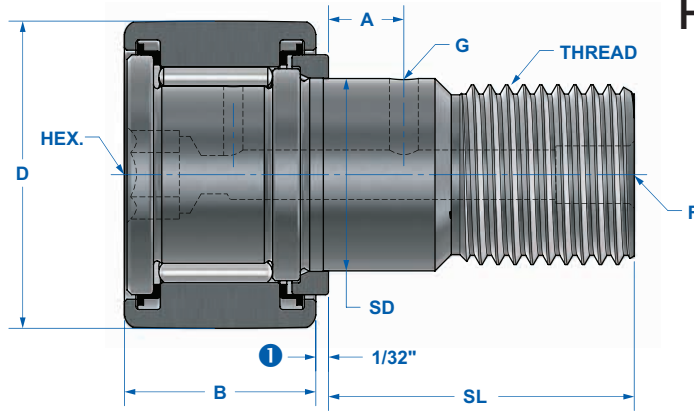

					CAPACITIES				MOUNTING DATA			BASIC NUMBER
F	A	G	SOCKET HEAD WRENCH SIZE	SPEED LIMIT [rpm]	C	Co	Max. Allow. Load [lbf]	Track Capacity @ 40 Rc [lbf]	Max. Clamping Torque [in*lb] 4	Hsg. Bore + .0005 - .0000	Min. Boss Dia.	
Lube Fitting 3	Loc.	Dia.			[lbf]	[lbf] 5						
2	-	-	1/8	5,000	770	1,590	700	430	20	0.2500	0.34	-16
2	-	-	1/8	5,000	770	1,590	700	480	20	0.2500	0.34	-18
2	-	-	1/8	5,000	970	2,500	1,200	770	55	0.3125	0.47	-20
2	-	-	1/8	5,000	970	2,500	1,200	850	55	0.3125	0.47	-22
3/16	0.250	0.093	3/16	5,000	1,800	4,150	2,920	1,070	150	0.4375	0.60	-24
3/16	0.250	0.093	3/16	5,000	1,800	4,150	2,920	1,240	150	0.4375	0.60	-28
3/16	0.250	0.093	1/4	4,500	2,300	6,150	4,100	1,690	390	0.6250	0.78	-32
3/16	0.250	0.093	1/4	4,500	2,300	6,150	4,100	1,900	390	0.6250	0.78	-36
3/16	0.312	0.093	1/4	3,900	4,000	8,500	5,800	2,440	750	0.7500	1.00	-40
3/16	0.312	0.093	1/4	3,900	4,000	8,500	5,800	2,680	750	0.7500	1.00	-44
3/16	0.375	0.093	5/16	3,100	4,900	11,300	7,900	3,320	900	0.8750	1.09	-48
3/16	0.375	0.093	5/16	3,100	4,900	11,300	7,900	3,600	900	0.8750	1.09	-52
3/16	0.437	0.125	5/16	2,600	6,400	15,850	11,400	4,550	1,350	1.0000	1.25	-56
3/16	0.437	0.125	5/16	2,600	6,400	15,850	11,400	4,900	1,350	1.0000	1.25	-60
3/16	0.500	0.125	7/16	2,200	9,600	21,200	16,700	6,500	1,700	1.1250	1.40	-64
3/16	0.500	0.125	7/16	2,200	9,600	21,200	16,700	7,300	1,700	1.1250	1.40	-72
3/16	0.562	0.125	1/2	2,000	12,900	33,000	25,400	9,400	2,050	1.2500	1.70	-80
3/16	0.562	0.125	1/2	2,000	12,900	33,000	25,400	10,400	2,050	1.2500	1.70	-88
1/4	0.625	0.187	5/8	1,600	17,000	49,900	36,600	13,300	3,000	1.5000	2.00	-96
1/4	0.625	0.187	5/8	1,600	17,000	49,900	36,600	14,400	3,000	1.5000	2.00	-104
1/4	0.687	0.187	5/8	1,400	24,300	63,250	51,000	17,300	3,000	1.7500	2.45	-112
1/4	0.750	0.187	3/4	1,300	25,600	89,550	68,000	22,000	3,000	2.0000	2.75	-128
1/4 NPT	0.875	0.187	7/8	1,000	44,900	136,000	99,000	35,000	3,000	2.5000	3.25	-160
1/4 NPT	1.000	0.187	1	800	61,600	161,300	160,000	52,000	3,000	3.0000	4.00	-192
1/4 NPT	1.250	0.187	1 1/4	700	79,400	237,800	217,000	71,000	3,000	3.5000	4.50	-224

2 Sizes CH 16 L through CH 22 L have a 1/8 inch hole at the flange end only.
 3 Sizes CH 16 LW through CH 22 LW cannot be relubricated.
 4 Torque may be doubled for completely dry threads.

5 Bearing Static Capacity provided for comparison only.
 6 HexLube® Cam Followers can be regreased through the hex head using a Lincoln #5803 or Alemite #B6783 needle nozzle adapter.

Yoke Rollers

Cylindrical and Crowned O.D.

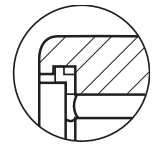
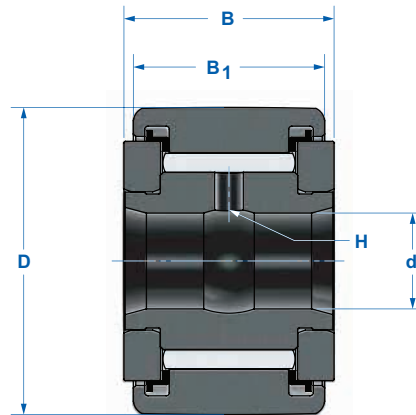

with
Glide-A-Seal®



without
seal

Series Y, Y-L

Nominal Size	PART NUMBER			ROLLER			INSIDE DIAMETER			WIDTH	
	Without Seals	With Seals	Sealed & Crowned O.D.	D	B ₁	CR	d			B	H
				Outside Diameter + .000 - .001	Roller Width + .000 - .005	Crown Radius	Nom.	Min.	Max.	Overall + .005 - .010	Oil Hole
3/4	Y 24	Y 24 L	CY 24 L	0.750	0.500	10	1/4	0.2496	0.2502	0.5625	0.093
7/8	Y 28	Y 28 L	CY 28 L	0.875	0.500	10	1/4	0.2496	0.2502	0.5625	0.093
1	Y 32	Y 32 L	CY 32 L	1.000	0.625	12	5/16	0.3121	0.3127	0.6875	0.093
1 1/8	Y 36	Y 36 L	CY 36 L	1.125	0.625	12	5/16	0.3121	0.3127	0.6875	0.093
1 1/4	Y 40	Y 40 L	CY 40 L	1.250	0.750	14	3/8	0.3746	0.3752	0.8125	0.093
1 3/8	Y 44	Y 44 L	CY 44 L	1.375	0.750	14	3/8	0.3746	0.3752	0.8125	0.093
1 1/2	Y 48	Y 48 L	CY 48 L	1.500	0.875	20	7/16	0.4371	0.4377	0.9375	0.093
1 5/8	Y 52	Y 52 L	CY 52 L	1.625	0.875	20	7/16	0.4371	0.4377	0.9375	0.093
1 3/4	Y 56	Y 56 L	CY 56 L	1.750	1.000	20	1/2	0.4996	0.5002	1.0625	0.093
1 7/8	Y 60	Y 60 L	CY 60 L	1.875	1.000	20	1/2	0.4996	0.5002	1.0625	0.093
2	Y 64	Y 64 L	CY 64 L	2.000	1.250	24	5/8	0.6246	0.6252	1.3125	0.093
2 1/4	Y 72	Y 72 L	CY 72 L	2.250	1.250	24	5/8	0.6246	0.6252	1.3125	0.093
2 1/2	Y 80	Y 80 L	CY 80 L	2.500	1.500	30	3/4	0.7496	0.7502	1.5625	0.125
2 3/4	Y 88	Y 88 L	CY 88 L	2.750	1.500	30	3/4	0.7496	0.7502	1.5625	0.125
3	Y 96	Y 96 L	CY 96 L	3.000	1.750	30	1	0.9995	1.0001	1.8125	0.125
3 1/4	Y 104	Y 104 L	CY 104 L	3.250	1.750	30	1	0.9995	1.0001	1.8125	0.125
3 1/2	Y 112	Y 112 L	CY 112 L	3.500	2.000	30	1 1/8	1.1245	1.1251	2.0625	0.125
4	Y 128	Y 128 L	CY 128 L	4.000	2.250	30	1 1/4	1.2495	1.2501	2.3125	0.125
5	Y 160	Y 160 L	CY 160 L	5.000	2.750	48	1 3/4	1.7495	1.7501	2.8750	0.187
6	Y 192	Y 192 L	CY 192 L	6.000	3.250	56	2 1/4	2.2495	2.2501	3.3750	0.187
7	Y 224	Y 224 L	CY 224 L	7.000	3.750	60	2 3/4	2.7495	2.7501	3.8750	0.187

All dimensions are in inches.

Axial clamping of the inner ring is recommended.

Yoke Rollers

Cylindrical and Crowned O.D.

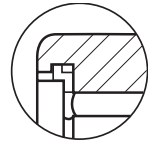
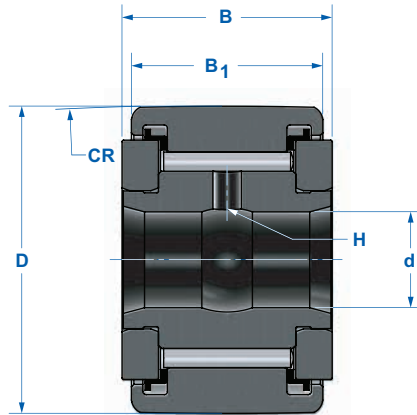

with
Glide-A-Seal®



without
seal

Series C-YL

SPEED LIMIT [rpm]	CAPACITIES			MOUNTING DATA				MIN. BOSS DIA.	APPROX. WEIGHT [lbs]	BASIC NUMBER
	C	C ₀	Track Capacity @ 40 Rc	Transition Fit		Press Fit				
	Dynamic Capacity [lbf] ①	Static Capacity [lbf] ②		Max.	Min.	Max.	Min.			
3,930	1,800	4,150	880	0.2497	0.2493	0.2505	0.2501	0.50	0.05	-24
3,930	1,800	4,150	1,030	0.2497	0.2493	0.2505	0.2501	0.50	0.07	-28
3,140	2,300	6,150	1,690	0.3122	0.3118	0.3130	0.3126	0.64	0.12	-32
3,140	2,300	6,150	1,900	0.3122	0.3118	0.3130	0.3126	0.64	0.15	-36
2,620	4,200	8,500	2,440	0.3747	0.3743	0.3755	0.3751	0.76	0.20	-40
2,620	4,200	8,500	2,680	0.3747	0.3743	0.3755	0.3751	0.76	0.26	-44
2,250	5,000	11,300	3,320	0.4372	0.4368	0.4380	0.4376	0.89	0.35	-48
2,250	5,000	11,300	3,600	0.4372	0.4368	0.4380	0.4376	0.89	0.44	-52
1,970	6,400	15,850	4,550	0.4997	0.4993	0.5007	0.5003	1.05	0.58	-56
1,970	6,400	15,850	4,900	0.4997	0.4993	0.5007	0.5003	1.05	0.67	-60
1,570	9,600	21,200	6,500	0.6247	0.6243	0.6257	0.6253	1.20	0.92	-64
1,570	9,600	21,200	7,300	0.6247	0.6243	0.6257	0.6253	1.20	1.23	-72
1,310	12,800	33,000	9,400	0.7497	0.7493	0.7507	0.7503	1.31	1.75	-80
1,310	12,800	33,000	10,400	0.7497	0.7493	0.7507	0.7503	1.31	2.20	-88
1,060	17,000	49,900	13,300	0.9996	0.9991	1.0008	1.0003	2.00	2.88	-96
1,060	17,000	49,900	14,400	0.9996	0.9991	1.0008	1.0003	2.00	3.49	-104
980	24,300	63,250	17,300	1.1246	1.1241	1.1258	1.1253	2.39	4.52	-112
940	30,000	89,550	22,000	1.2496	1.2491	1.2508	1.2503	2.62	6.76	-128
720	47,200	136,000	35,000	1.7496	1.7491	1.7508	1.7503	3.50	12.70	-160
590	62,900	165,500	52,000	2.2496	2.2491	2.2508	2.2503	4.50	21.40	-192
520	79,400	237,800	71,000	2.7496	2.7491	2.7508	2.7503	5.25	34.20	-224

① Normal operating loads should not exceed 50% of the bearing dynamic capacity.

② Bearing Static Capacity provided for comparison only.

Caged Roller Followers

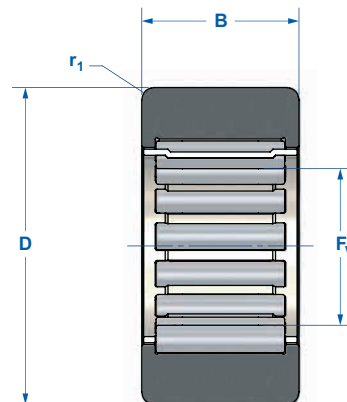

Series **SRF** (without seals), **SRF-SS** (with seals)

PART NUMBER	ROLLER			INSIDE DIAMETER			r ₁ Corner Radius	APPROX. WEIGHT [lbs]	MATCHING INNER RINGS (See page 32)
	D		B	F _w					
	Max.	Min.	+ .000 - .005	Nom.	Min.	Max.			
SRF 20	1.000	0.999	0.495	1/2	0.5005	0.5014	0.04	0.07	—
SRF 20 SS	1.000	0.999	0.620	1/2	0.5005	0.5014	0.04	0.08	—
SRF 25	1.250	1.249	0.620	5/8	0.6258	0.6267	0.06	0.13	—
SRF 25 SS	1.250	1.249	0.620	5/8	0.6258	0.6267	0.06	0.14	—
SRF 30	1.500	1.499	0.745	3/4	0.7509	0.7518	0.06	0.23	IR 7153, IR 7153 C
SRF 30 SS	1.500	1.499	0.745	3/4	0.7509	0.7518	0.06	0.23	IR 7153, IR 7153 C
SRF 35	1.750	1.749	0.745	7/8	0.8759	0.8768	0.06	0.32	IR 7173, IR 7173 C
SRF 35 SS	1.750	1.749	0.745	7/8	0.8759	0.8768	0.06	0.33	IR 7173, IR 7173 C
SRF 40	2.000	1.999	0.995	1	1.0009	1.0018	0.08	0.59	IR 7194, IR 7194 C
SRF 40 SS	2.000	1.999	0.995	1	1.0009	1.0018	0.08	0.56	IR 7194, IR 7194 C
SRF 45	2.250	2.249	0.995	1 1/4	1.2510	1.2519	0.08	0.69	IR 7234
SRF 45 SS	2.250	2.249	0.995	1 1/4	1.2510	1.2519	0.08	0.58	IR 7234
SRF 50	2.500	2.499	0.995	1 3/8	1.3760	1.3769	0.08	0.86	IR 7254, IR 7254 D
SRF 50 SS	2.500	2.499	0.995	1 3/8	1.3760	1.3769	0.08	0.86	IR 7254, IR 7254 D
SRF 55	2.750	2.749	1.245	1 1/2	1.5010	1.5019	0.08	1.34	IR 7275, IR 7275 C
SRF 55 SS	2.750	2.749	1.245	1 1/2	1.5010	1.5019	0.08	1.31	IR 7275, IR 7275 C
SRF 60	3.000	2.999	1.245	1 5/8	1.6260	1.6269	0.08	1.61	IR 7295, IR 7295 C
SRF 65	3.250	3.249	1.245	1 3/4	1.7510	1.7520	0.10	1.91	IR 7315, IR 7315 C
SRF 70	3.500	3.499	1.245	1 7/8	1.8760	1.8770	0.10	2.23	IR 7335
SRF 75	3.750	3.749	1.245	2	2.0011	2.0021	0.10	2.59	IR 7355, IR 7355 D
SRF 80	4.000	3.999	1.245	2 1/4	2.2511	2.2521	0.10	2.75	IR 8405, IR 8405 D

All dimensions are in inches.

Normal operating loads should not exceed the bearing dynamic capacity.

Roller followers used without inner rings require a shaft with minimum hardness of Rc 58 and surface finish of 16 rms or better.

Standard configuration of roller follower series SRF-SS is with seal lips facing outward. To specify roller followers with seal lips facing inward, replace suffix -SS with suffix -RR. (example: SRF 30 RR).

Caged Roller Followers

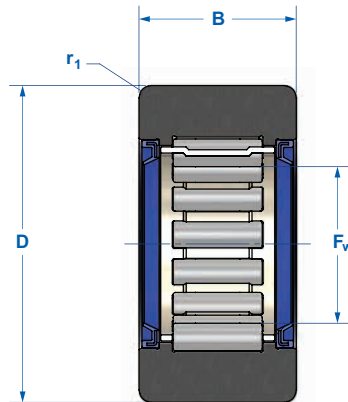
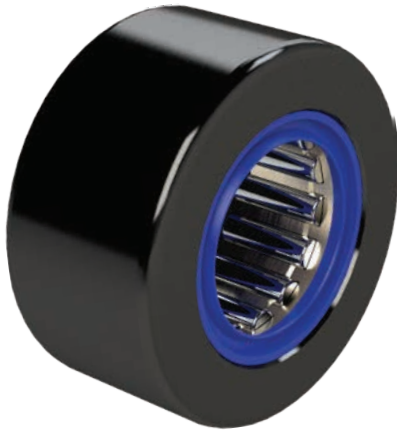

Series **SRF** (without seals), **SRF-SS** (with seals)

CAPACITIES

C Dynamic Capacity [lbf]	C ₀ Static Capacity [lbf] ^①	Track Capacity @ 40 Rc [lbf]	Critical Angle [deg] ^②	Speed Limit (grease) [rpm] ^③	Recommended Shaft Diameter (without Inner Ring)		PART NUMBER
					Max.	Min.	
1,900	2,200	1,280	60.0	10,900	0.5000	0.4996	SRF 20
1,200	1,300	1,650	60.0	7,600	0.5000	0.4996	SRF 20 SS
2,700	3,300	1,950	60.1	8,700	0.6250	0.6246	SRF 25
1,600	1,600	1,950	60.1	6,100	0.6250	0.6246	SRF 25 SS
4,400	5,900	2,900	50.5	7,200	0.7500	0.7496	SRF 30
2,300	2,700	2,900	51.2	5,100	0.7500	0.7496	SRF 30 SS
4,700	6,500	3,400	47.5	6,200	0.8750	0.8745	SRF 35
2,400	3,000	3,400	48.1	4,400	0.8750	0.8746	SRF 35 SS
6,900	11,300	5,200	41.8	5,400	1.0000	0.9995	SRF 40
5,000	7,500	5,200	41.8	3,800	1.0000	0.9995	SRF 40 SS
7,800	13,900	5,800	35.6	4,300	1.2500	1.2495	SRF 45
4,900	8,400	5,800	36.0	3,100	1.2500	1.2495	SRF 45 SS
8,300	15,700	6,450	32.3	3,900	1.3750	1.3745	SRF 50
5,100	8,900	6,450	34.4	2,800	1.3750	1.3745	SRF 50 SS
11,500	22,800	9,250	32.3	3,600	1.5000	1.4995	SRF 55
8,000	15,800	9,250	31.2	2,500	1.5000	1.4995	SRF 55 SS
9,400	20,700	10,100	30.1	3,300	1.6250	1.6245	SRF 60
12,500	26,600	10,500	28.5	3,000	1.7500	1.7495	SRF 65
10,100	23,800	11,300	26.8	2,800	1.8750	1.8745	SRF 70
10,600	25,800	12,100	24.9	2,700	2.0000	1.9994	SRF 75
12,700	26,700	12,950	28.8	2,300	2.2500	2.2494	SRF 80

^① Bearing Static Capacity provided for comparison only.

^② For oscillatory application with angle of oscillation less than critical angle, consult RBC engineering department for revised fatigue calculation.

^③ Speed limit of sealed roller followers is determined by maximum seal surface speed. For roller followers without seals, speed limit may be increased by 30% with oil lubrication.

Precision Ground Inner Rings

for Use with Caged Roller Followers

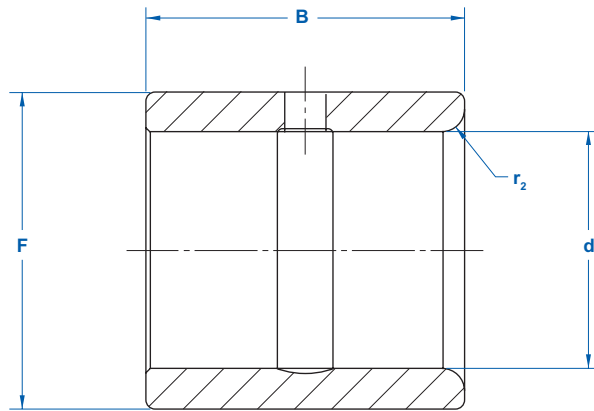

Series IR

PART NUMBER	INSIDE DIAMETER			OUTSIDE DIAMETER			WIDTH	SHAFT FILLET
	d			F			B	r ₂
	Nom.	Min.	Max.	Nom.	Max.	Min.	+ .000 - .005	Max.
IR 7153	1/2	0.4996	0.5000	3/4	0.7493	0.7488	0.760	0.04
IR 7153 C	9/16	0.5621	0.5625	3/4	0.7493	0.7488	0.760	0.04
IR 7173	5/8	0.6246	0.6250	7/8	0.8743	0.8738	0.760	0.04
IR 7173 C	11/16	0.6871	0.6875	7/8	0.8743	0.8738	0.760	0.04
IR 7194	3/4	0.7496	0.7500	1	0.9993	0.9988	1.010	0.04
IR 7194 C	13/16	0.8120	0.8125	1	0.9993	0.9988	1.010	0.04
IR 7234	1	0.9995	1.0000	1 1/4	1.2491	1.2485	1.010	0.04
IR 7254 D	1	0.9995	1.0000	1 3/8	1.3741	1.3735	1.010	0.04
IR 7254	1 1/8	1.1245	1.1250	1 3/8	1.3741	1.3735	1.010	0.04
IR 7275	1 3/16	1.1870	1.1875	1 1/2	1.4990	1.4984	1.260	0.06
IR 7275 C	1 1/4	1.2495	1.2500	1 1/2	1.4990	1.4984	1.260	0.06
IR 7295	1 5/16	1.3120	1.3125	1 5/8	1.6240	1.6234	1.260	0.06
IR 7295 C	1 3/8	1.3745	1.3750	1 5/8	1.6240	1.6234	1.260	0.06
IR 7315	1 7/16	1.4370	1.4375	1 3/4	1.7490	1.7484	1.260	0.06
IR 7315 C	1 1/2	1.4995	1.5000	1 3/4	1.7490	1.7484	1.260	0.06
IR 7335	1 9/16	1.5620	1.5625	1 7/8	1.8740	1.8734	1.260	0.06
IR 7355 D	1 5/8	1.6245	1.6250	2	1.9989	1.9982	1.260	0.06
IR 7355	1 11/16	1.6870	1.6875	2	1.9989	1.9982	1.260	0.06
IR 8405 D	1 11/16	1.6870	1.6875	2 1/4	2.2489	2.2482	1.260	0.06
IR 8405	1 3/4	1.7495	1.7500	2 1/4	2.2489	2.2482	1.260	0.06

All dimensions are in inches.

Precision Ground Inner Rings

for Use with Caged Roller Followers

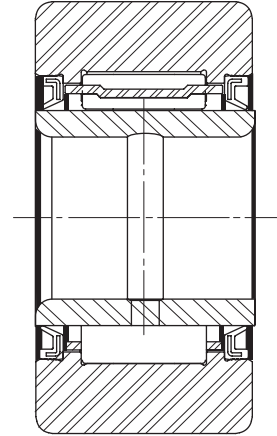
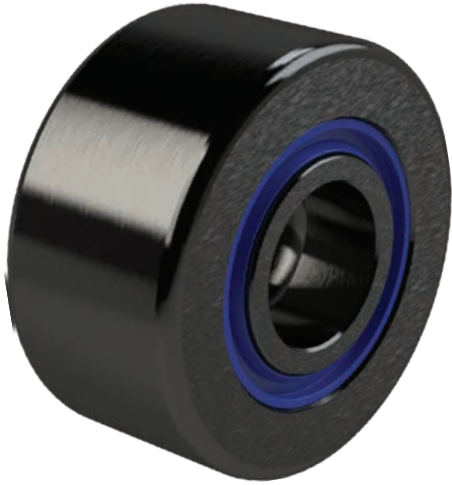

Series SRF with Inner Ring

APPROX. WEIGHT [lbs]	MATCHING ROLLER FOLLOWERS (See page 30)	RECOMMENDED SHAFT DIAMETER						PART NUMBER
		Transition Fit - ISO g6			Press Fit - ISO m5			
		Max.	Min.	Mean Fit	Max.	Min.	Mean Fit	
0.050	SRF 30, SRF 30 SS	0.4997	0.4993	.0003L	0.5006	0.5003	.0006T	IR 7153
0.040	SRF 30, SRF 30 SS	0.5622	0.5618	.0003L	0.5631	0.5628	.0006T	IR 7153 C
0.059	SRF 35, SRF 35 SS	0.6247	0.6243	.0003L	0.6256	0.6253	.0006T	IR 7173
0.046	SRF 35, SRF 35 SS	0.6872	0.6868	.0003L	0.6881	0.6878	.0006T	IR 7173 C
0.094	SRF 40, SRF 40 SS	0.7497	0.7492	.0003L	0.7507	0.7503	.0007T	IR 7194
0.072	SRF 40, SRF 40 SS	0.8122	0.8117	.0003L	0.8132	0.8128	.0007T	IR 7194 C
0.121	SRF 45, SRF 45 SS	0.9997	0.9992	.0003L	1.0007	1.0003	.0007T	IR 7234
0.192	SRF 50, SRF 50 SS	0.9997	0.9992	.0003L	1.0007	1.0003	.0007T	IR 7254 D
0.134	SRF 50, SRF 50 SS	1.1247	1.1242	.0003L	1.1257	1.1253	.0008T	IR 7254
0.228	SRF 55, SRF 55 SS	1.1871	1.1865	.0004L	1.1883	1.1879	.0008T	IR 7275
0.183	SRF 55, SRF 55 SS	1.2496	1.2490	.0004L	1.2508	1.2504	.0008T	IR 7275 C
0.247	SRF 60	1.3121	1.3115	.0004L	1.3133	1.3129	.0008T	IR 7295
0.201	SRF 60	1.3746	1.3740	.0004L	1.3758	1.3754	.0008T	IR 7295 C
0.269	SRF 65	1.4371	1.4365	.0004L	1.4383	1.4379	.0008T	IR 7315
0.217	SRF 65	1.4996	1.4990	.0004L	1.5008	1.5004	.0008T	IR 7315 C
0.288	SRF 70	1.5621	1.5615	.0004L	1.5633	1.5629	.0008T	IR 7335
0.366	SRF 75	1.6246	1.6240	.0004L	1.6258	1.6254	.0008T	IR 7355 D
0.308	SRF 75	1.6871	1.6865	.0004L	1.6883	1.6879	.0008T	IR 7355
0.609	SRF 80	1.6871	1.6865	.0004L	1.6883	1.6879	.0008T	IR 8405 D
0.544	SRF 80	1.7496	1.7490	.0004L	1.7508	1.7504	.0008T	IR 8405

Technical Data

Cam Followers and Yoke Rollers

Introduction to Cam Follower Technology

Safety Precaution

In rare cases a bearing failure may cause great mechanical damage or even lead to personal injury. To help prevent such losses, you may contact RBC's engineering staff to review your application details. The engineering staff's review will assist you in identifying potential problem areas and suggest modifications to improve bearing performance in your application.

The engineering staff at RBC has many years of experience with a large variety of applications and operating conditions. If you have a safety related application and would like an evaluation by RBC's engineering department, please submit your application details in confidence.

1. Difference from Standard Bearings

The outer rings of regular ball and roller bearings are typically mounted in rigid housings providing support around the entire circumference. Individual roller forces are transmitted through the outer ring directly into the housing with no major deformations.

By contrast, cam followers and yoke rollers are supported at a single point on their circumference. Individual roller forces produce bending moments on the outer ring around the point of contact. The effects are outer ring deformation with reversed bending stresses in dynamic applications, a reduced load zone, and a higher maximum roller load (see **Figure 1**).

To keep deformation to a minimum, the outer ring of a cam follower must have a considerably heavier cross section than a standard bearing. This requirement conflicts with the desire

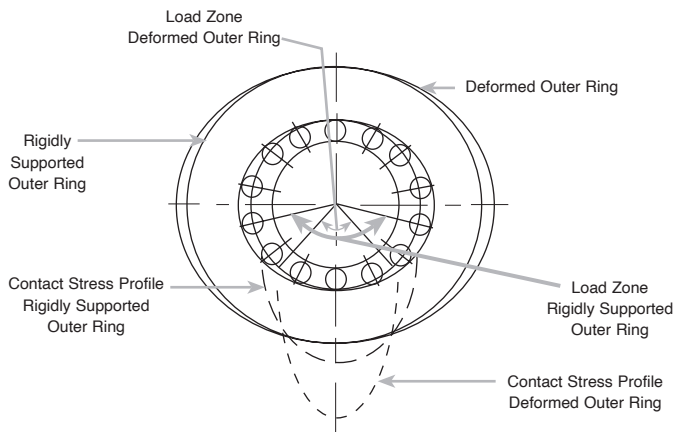

Figure 1 Load Zone & Maximum Contact Stress

for maximum dynamic bearing capacity which needs as large a roller diameter as possible. RBC cam followers and yoke rollers provide an optimum compromise between outer ring strength and theoretical bearing capacity.

2. Capacity and Load Limits

Evaluation of the expected service life and limit loads of cam followers is more complex than with housed bearings. In addition to the static and dynamic capacity of the rolling elements, outer ring deformation, track capacity, and cam follower stud bending stress must be considered. In yoke rollers, the pin shear stress must be considered.

RBC lists the static bearing capacity for reference purposes only. Typically, the maximum allowable load is a function of the maximum permissible bending stress of the stud or the outer ring. For best results, the operating loads should not exceed the lower of track capacity or 50% of the dynamic capacity.

2.1 Capacity of Rolling Element Bearing

Equations for *static and dynamic capacities* of roller bearings are given in *ANSI/ABMA Standard 11*. The more recent revisions leave it up to the manufacturer to introduce factors which account for internal design features and operating conditions.

For cam followers and yoke rollers RBC has chosen to apply a conservative rating system, so a direct comparison with capacity figures of competitive products may not be possible.

2.2 Track Capacity

Track capacity is that load which a track subject to a uniform contact stress can withstand without excessive plastic deformation. It is directly related to track hardness. The published track capacity is based on a hardness of *HRC 40*. For other track hardness values the track capacity must be modified with factors from **Table 1**.

Track Hardness [HRC]	Material Strength [psi]	Modification Factor
26	128,000	0.45
32	146,000	0.61
36	165,000	0.79
40	182,000	1.00
44	204,000	1.24
47	229,000	1.50
50	247,000	1.78
53	266,000	2.09
56	281,000	2.42
58	298,000	2.78

Table 1 Track Capacity Adjustment Factors

Alternatively, contact stress can be easily calculated and compared directly to the strength of material. The equation for the Hertz contact stress between a cylindrical cam follower outer ring and a flat steel track is given by “Roark, Formulas for Stress and Strain” as:

$$\sigma_{c \max} = 3,237 * \sqrt{\frac{F}{l_{\text{eff}} * D}} \quad [\text{psi}] \quad (1)$$

where

- F** = radial load [lbf]
- l_{eff}** = length of outer ring contact [in]
- D** = outer ring diameter [in]

It can be shown that for infinite life the ultimate tensile strength of track and roller must be at least equal to the maximum contact stress $\sigma_{c \max}$.

Determine the required minimum track hardness for an RBC cam follower S56L operating under a 3,000 lbf radial load.

Solution:

$$\sigma_{c \max} = 3,237 * \sqrt{\frac{3,000 \text{ lbf}}{0.8 \text{ in} * 1.75 \text{ in}}} = 149,800 \text{ psi}$$

Referring to **Table 1**, 149,800 psi is between 146,000 psi (HRc32) and 165,000 (HRc 36). Interpolation yields a minimum track hardness of HRc 33.

Example 1 Min. Track Hardness

2.3. Bending and Shear Stresses

2.3.1 Cam Follower Stud Bending Stress

If the load over the width of the outer ring is evenly distributed, it may be replaced by a single concentrated force **F** [lbf] acting at the center of the cam follower (see **Figure 2**). Assuming that the cam follower stud has been tightly mounted in a housing bore flush with the end plate, this concentrated force generates a bending moment **M_b**.

$$M_b = F * \left(\frac{B}{2} + \frac{1}{32} \right) \quad [\text{in} * \text{lbf}] \quad (2)$$

where

- B** = outer ring width [in]
- 1/32** = cam follower overhang [in]
(sizes 160 and above = 1/16)

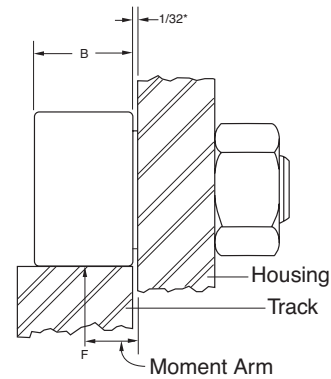

Figure 2 Theoretical Moment Arm without stud deflection

The bending moment generates a bending stress in the cam follower stud of approximate magnitude

$$\sigma_b = 10 * \frac{M_b}{SD^3} \quad [\text{psi}] \quad (3)$$

where

SD = Stud Diameter [in]

Standard cam follower studs are heat treated to a hardness of HRc 58 min in the raceway area only. The hardness in other areas of the stud is typically in a range of HRc 20 -22 with an ultimate strength of material of 110,000 -120,000 psi.

RBC bases the maximum allowable load of stud type cam followers on a theoretical stud bending stress of 100,000 psi. Standard stud cam followers and heavy stud cam followers differ in stud diameter, which permits higher operating loads and more resistance to impact loading for the heavy stud version. High stud strength cam followers are available by special order.

In most applications the stud will deflect away from the load, which causes the point of attack to shift toward the support, shortening the moment arm and reducing the effective bending moment (see **Figure 3**).

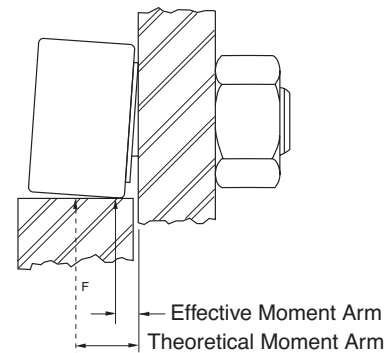

Figure 3 Effective Moment Arm with stud deflection

Technical Data

Tests show that this deflection yields a *safety factor* of at least 2 over RBC's maximum allowable load. However, this effect may not be sufficient to avoid damage in severely misaligned applications where the load is applied at the very extreme outboard edge of the cam follower outer ring.

Where misalignment is a problem, RBC recommends *crowned cam followers*.

Cam follower S64L supports a load of 6,000 lbf. The stud diameter is .875", the outer ring width 1.25". Determine the theoretical bending stress at the stud housing interface.

Solution:

$$M_b = 6,000 \text{ lbf} * (1.25 \text{ in} / 2 + 1 / 32 \text{ in}) = 3,938 \text{ in} * \text{lbf}$$

$$\sigma_b = 10 * \frac{3,938 \text{ in} * \text{lbf}}{(.875 \text{ in})^3} = 58,776 \text{ psi}$$

Example 2 Bending Stress

2.3.2 Yoke Roller Pin Shear Stress

Yoke rollers are mounted with a pin in a yoke. Under load the pin is subject to shear and bending stresses.

RBC recommends that the yoke arms are located as close to the yoke roller as possible, so that bending stress can be ignored. In case of widely spaced pin supports, the resulting pin deflection may cause yoke roller damage.

The pin shear stress can be calculated with

$$\sigma_s = 2 * \frac{F}{\pi * d^2} \quad [\text{psi}] \quad (4)$$

where

d = Pin Diameter [in]

The permissible stress depends on the pin material selection.

Determine the shear stress of the .375 diameter pin for yoke roller Y40L, loaded radially with 3,200 lbf.

Solution:

$$\sigma_s = 2 * \frac{3,200 \text{ lbf}}{\pi * (.375)^2} = 14,487 \text{ [psi]}$$

Example 3 Shear Stress

2.4 Outer Ring Stress and Deformation

The exact calculation of these values is beyond the scope of this introduction. The following method may be used for a (high) first estimate of the outer ring tensile stress at the inside diameter opposite the contact point of a single row cam or roller follower. The assumption is that the entire load is supported by only 2 rollers straddling the point of contact:

$$\sigma_{b \text{ max}} = \frac{6 * F * D_i * \pi}{z * b * (D - D_i)^2} \quad [\text{psi}] \quad (5)$$

where

- F** = cam follower load [lbf]
- D_i** = outer ring raceway diameter [in]
- D** = outer ring outside diameter [in]
- z** = number of rollers per row
- b** = idealized outer ring width [in]

Estimate the outer ring tensile stress of yoke roller Y56L subject to a load of 6,000 lbf. The yoke roller has 25 rollers, the outer ring outside diameter = 1.750 in., the outer ring raceway diameter = 1.125 in., the idealized outer ring width = .690 in.

Solution:

$$\sigma_{b \text{ max}} = \frac{6 * 6,000 \text{ lbf} * 1.125 * \pi}{25 * .690 \text{ in} * (1.75 \text{ in} - 1.125 \text{ in})^2} = 18,880 \text{ [psi]}$$

Example 4 Tensile Stress

3. Fatigue Life

Fatigue life, L₁₀ [rev, hrs], is a statistical measure of the life which 90% of a large group of apparently identical rolling element bearings will complete or exceed. For a single bearing, L₁₀ also refers to the life associated with 90% reliability.

The relationship between fatigue or rating life, capacity and load is:

$$L_{10 \text{ rev}} = \left(\frac{C}{P_e} \right)^{\frac{10}{3}} \quad (6)$$

where

- L_{10 rev}** = Rating life [10⁶ rev]
- C** = Dynamic capacity [lbf]
- P_e** = equivalent radial load

To obtain the rating life in hours, use

$$L_{10 \text{ hrs}} = \frac{16,667}{n_e} * \left(\frac{C}{P_e}\right)^{\frac{10}{3}} \quad (7)$$

where

$$\begin{aligned} L_{10 \text{ hrs}} &= \text{Rating life [hours]} \\ n_e &= \text{equivalent speed [rpm]} \end{aligned}$$

In case of constant speed, the equivalent speed equals the constant bearing speed. In all other cases the equivalent speed is the weighted average of all individual speed components.

$$n_e = \sum \left(\frac{n_i * t_i}{100}\right) = \frac{n_1 * t_1}{100} + \frac{n_2 * t_2}{100} + \dots \quad (8)$$

where

$$\begin{aligned} n_i &= \text{individual speed component [rpm]} \\ t_i &= \text{time interval in percent of total time} \end{aligned}$$

In case of constant load, the equivalent radial load equals the constant load. To compute the equivalent load for all other cases, use:

$$P_e = \sqrt[q]{\sum \left(\frac{F_i^q * n_i * t_i}{n_e * 100}\right)} = \sqrt[q]{\sum \left(\frac{F_1^q * n_1 * t_1}{n_e * 100}\right) + \left(\frac{F_2^q * n_2 * t_2}{n_e * 100}\right) + \dots} \quad (9)$$

where

$$\begin{aligned} q &= 10/3 \text{ for roller bearings} \\ F_i &= \text{individual radial load [lbf]} \end{aligned}$$

4. Speed Limit and Maximum Acceleration

4.1 Speed Limit

The limiting speed of rolling element bearings is primarily a function of size and internal design. The speed limits given in this catalog should not be exceeded on a continuous basis to prevent premature failure due to excessive temperature. Contact RBC for solutions to high speed applications.

4.2 Maximum Acceleration (Deceleration)

A sufficiently large tangential friction force F_t acting between outside diameter and track is needed to change the rotational speed of cam follower and yoke roller outer rings.

$$F_t = F * \mu \quad [\text{lbf}] \quad (10)$$

where

$$\mu = \text{coefficient of friction (outer ring to track)}$$

The force F_t produces a moment M_t , which must accelerate the masses of outer ring and rollers around the bearing axis, plus the rollers in the load zone around their own axes.

The moment M_t can be calculated using:

$$M_t = \frac{D * F_t}{2} \quad [\text{in} * \text{lbf}] \quad (11)$$

Accelerating the mass of the outer ring normally requires the largest part of moment M_t . Assuming a coefficient of friction of $\mu = 0.10$ and a typical cam follower design, the following equation may be used for an estimate of the permissible angular acceleration α :

$$\alpha_{\text{perm}} = \frac{6,000 * M_t}{B * D^4} \quad [\text{rad/sec}^2] \quad (12)$$

Excessive acceleration causes sliding of the outer ring on the track. The effects range from minor uniform wear on cam follower and track to flat spots on the cam follower with subsequent failure.

5. Mounting

5.1 Cam Followers

For greatest rigidity and strength, the end plate should be drawn up snugly against a boss or other flat surface of the housing. The tables on pages 10 throughout 27 list the maximum recommended clamping torque for lubricated threads, which is the normal condition. Use up to twice the listed torque for completely dry threads.

The housing bore should be drilled and reamed to the recommended tolerance. If a greater tolerance is needed, it should be added to the plus side to prevent cam follower damage during assembly. If the cam follower stud fits tightly into the housing bore, use an arbor press and apply pressure against the central portion of the flange. Never press against the rim of the flange or the outer ring.

Although wide blade *screwdrivers* may be used to hold slotted head cam followers during assembly, rounded tools conforming to the slot are preferable to avoid plastic deformation in the slot area.

RBC offers a convenient socket (**W** suffix) for hex wrenches to provide a more substantial grip, especially for 'blind hole' applications.

5.2 Eccentric Cam Followers

Eccentric cam followers are used when there is a need to make height adjustments between the cam follower and the track. By simply turning the entire cam follower inside the

Technical Data

housing it is possible to adjust the distance between the cam follower and the track by twice the eccentricity. However, due to the mechanical advantage that the eccentricity provides, it is inadvisable that the cam follower be adjusted over this entire range.

A very large force can be exerted on the track for a small applied adjusting torque as the eccentricity of the cam follower approaches $\pm 90^\circ$ from a starting position parallel to the track, in the housing. Adjustments should be limited to $\pm 45^\circ$ and the resulting preload should not exceed 10% of the cam follower's capacity.

The following equation can be used to find an appropriate adjusting torque.

$$T = 0.1 * C * e * \cos 45^\circ \text{ [in*lb]} \quad (13)$$

where

- T** = appropriate adjusting torque [lbft]
- C** = cam followers dynamic capacity [lbft]
- E** = eccentricity of cam follower [in]

CamCentric™ cam follower S48LWX has a dynamic capacity of 4,600 lb, and an eccentricity of 0.03 in. Determine the appropriate adjusting torque.

Solution:

$$T = 4,600 \text{ lbft} * 0.03 \text{ in} * 0.070711 = 9.76 \text{ in} * \text{lbft}$$

Example 5 Adjusting Torque

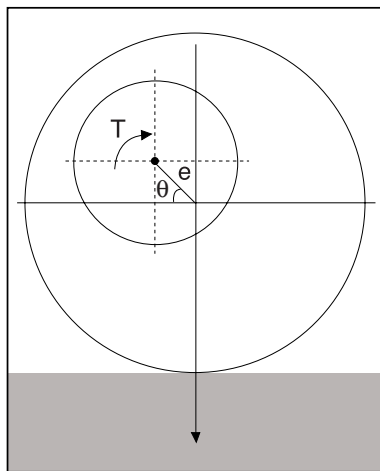

Figure 4

5.3 Yoke Rollers

RBC yoke rollers correspond in many respects to the same size cam follower, except they are mounted on a pin for use in yoke type applications for greater shock resistance.

Yoke rollers should be clamped axially or mounted within closely fitting side rails to prevent displacement of the end plates.

For applications with *heavy loads*, it is recommended to heat treat the pin and use a press fit for the inner ring. A soft pin and light press or push fit are sufficient for *lightly loaded* applications.

When press fitting a yoke roller, pressure should be applied centrally and uniformly *against the end plate*, never against the outer ring.

The pin should have a suitable lead-in chamfer or radius to prevent scoring and to hold the mounting force to a minimum.

5.4 Caged Roller Followers

Caged roller followers can operate directly on a hardened and ground shaft (HRc 58 min, 16 rms min surface finish) or can be used with matching inner rings.

Operating without an inner ring yields the largest possible shaft diameter with greatest strength and rigidity.

Axial guidance must be provided by the application. *It is recommended* to use hardened steel or bronze thrust washers with radial lubricating grooves as needed.

6. Lubrication

6.1 Track Lubrication

In most applications it is difficult to eliminate *all* cam follower misalignment. Misalignment causes the outer ring to thrust, which in needle bearing cam followers, produces wear of the seal followed by wear of the outer ring face and the stud flange or the end plate. In **RBC Rollers®** the wear is generally limited to the center thrust ring.

Misalignment where the axis of the cam follower is not perpendicular to the direction of rolling, typically produces the most severe thrust and also causes wear on the cam follower outside diameter, and the track. To reduce these symptoms as much as possible, the track must be lubricated. Lubrication also reduces wear stemming from excessive acceleration. Oil and grease are acceptable lubricants.

If the track cannot be lubricated, contact RBC Engineering for a review of the operating parameters to ensure that they do not exceed the limits of the bearing selected.

6.2 Bearing Lubrication

RBC Cam followers and yoke rollers are pre-lubricated with an *NLGI grade 2*, lithium soap, mineral oil based grease with EP additives.

RBC Roller® type cam followers and yoke rollers are normally lubricated for life and have no provisions for re-lubrication.

Needle roller type cam followers require re-lubrication depending on operating speed, duty cycle, operating environment, desired service life, etc.

For re-lubrication in service, mineral oil, or any good roller bearing grease on mineral oil basis may be used. Inquire about compatibility of greases with different base oil and thickener.

Except for the very small sizes (see tables), cam followers with screwdriver slots can be re-lubricated from both ends of the stud and through the housing. **Table 2** lists suitable drive fit Alemite fittings. Plugs are furnished by RBC to close off unused passages.

Size	Bearing P/N	Fitting P/N
1/2" - 11/16"	-16 to -22	3019
3/4" - 2 3/4"	-24 to -88	1728-B, 1646-B, 1992-B
3" - 4"	-96 to -128	1743, 1743-B
5" - up	160	any 1/4" NPT fitting

Table 2 Alemite fittings

Cam followers of the **HexLube®** series are supplied with a grease fitting at the bottom of the hex hole. Yoke rollers and sealed roller followers must be re-lubricated through the shaft.

HexLube® Cam Followers can be re-greased *through the hex head using a Lincoln #5803 or Alemite #B6783 needle nozzle adapter.*

7. Misalignment

Initial misalignment should not exceed *.001 in./in.* Any misalignment generates thrust forces between outer ring and flange or end plate. *Excessive thrusting* can lead to increased operating temperature and destruction of the seal in standard cam followers and yoke rollers.

Where misalignment and outer ring thrusting cannot be avoided, RBC recommends crowned outer rings or the **RBC Roller®** design which is more capable of withstanding thrust loads. Contact RBC engineers about thrust and load limits.

In a typical application, the cam follower runs on a track parallel to its axis and its surface can only support perpendicular forces. Under these constraints, thrust forces will be generated by misalignment, either because the cam follower axis is not parallel to the track (called *Type I Misalignment – Figure 5*), or the cam follower axis is not perpendicular to the direction of motion (called *Type II Misalignment – Figure 6*)

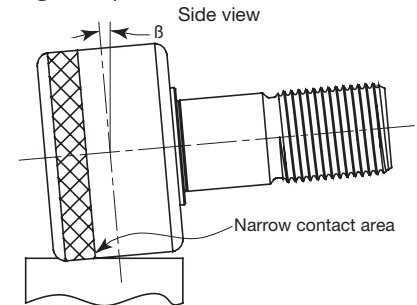

The cam follower axis is not parallel to track. Generates light thrust load.

Figure 5 Type I Misalignment

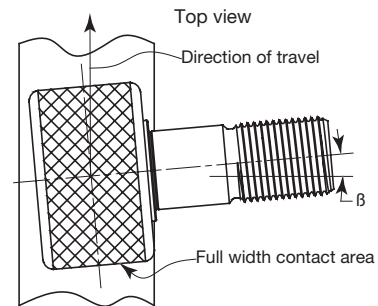

The cam follower axis is not perpendicular to the direction of travel. Generates heavy thrust load.

Figure 6 Type II Misalignment

8. Operating Temperature

The temperature limits of all standard cam followers and yoke rollers in this catalog, are determined by the temperature limits of the seals and the lubricant. With lower temperature, grease gradually becomes stiffer, increasing the rolling resistance of the cam follower.

Any application with the cam follower operating continuously below 0°F (-18°C), consult with **RBC Engineering** for a specific low temperature grease.

The maximum continuous operating temperature is +250°F (120°C), and for short periods, the maximum temperature may rise to +300°F (150°C). For continuous operation above +250°F (120°C), consult with **RBC Engineering** to determine the need for special high temperature grease and seal material.

RBC can provide special solutions for applications outside the normal operating temperature range.

Typical Applications

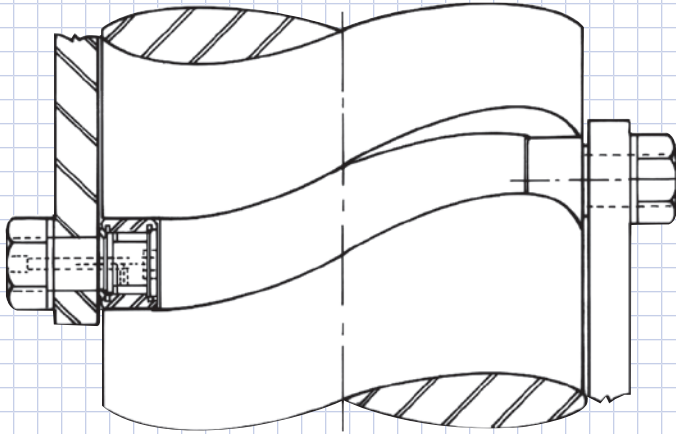

Drum Cam

A pair of heavy stud cam followers are shown mounted in linkages activated by a drum cam or grooved rotating shaft. A lubrication hole through the stud accepts a drive fitting for periodic relubrication.

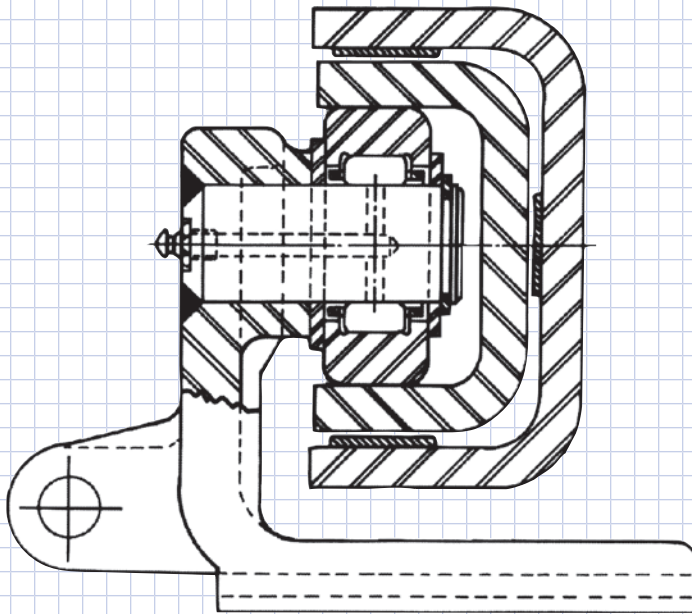
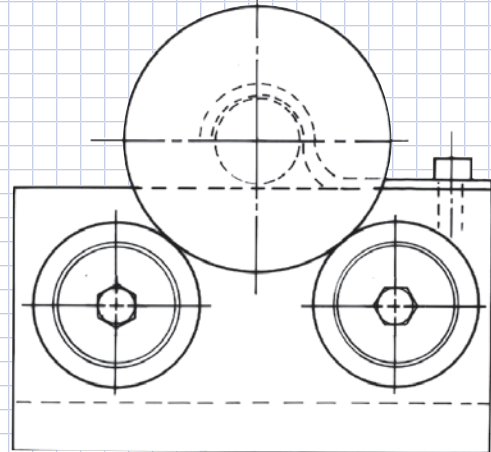
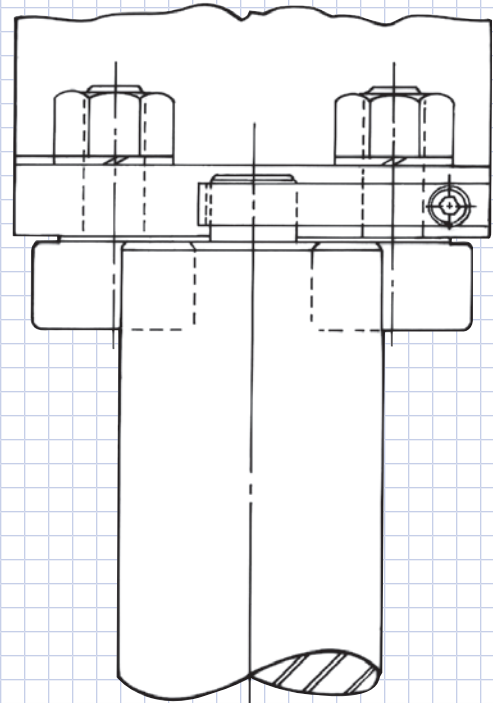

Material Handling Equipment

Carriage rollers and side rollers of lift trucks are typical applications where roller followers have performed exceedingly well. The heavy walled outer ring eliminates the need for a separate tire and bearing assembly.

Rewind Stands

Rewind stands for packaging material or printed coils make use of cam followers. A simple two or three point support consists simply of several cam followers acting on the journal or body of the roll. The upper bracket is optional and a very quick changeover results in either case.

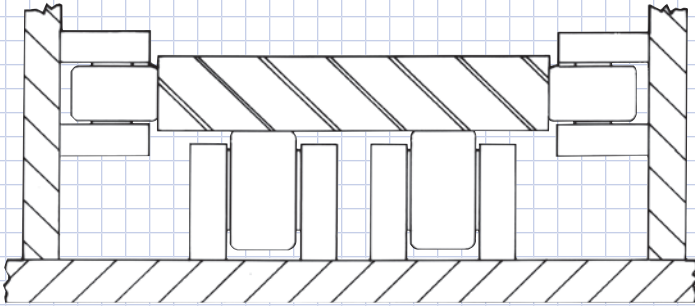
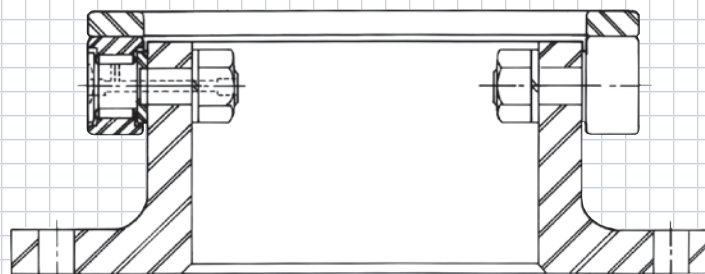
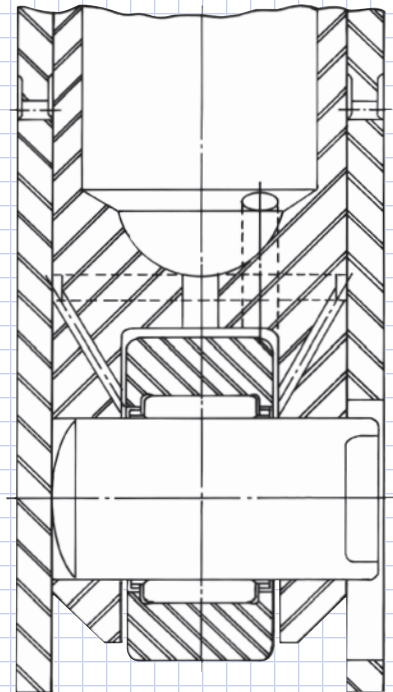
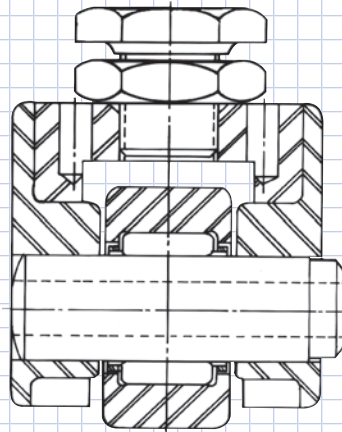

Table Supports

Yoke rollers may be effectively mounted to support tables, tracks or other machine members requiring linear motion. The illustration depicts horizontal location between yoke rollers, but this may be achieved by cam followers or CamCentric™ followers as well.

Internal Combustion Engines

RBC's yoke roller followers have found wide acceptance as valve tappet and fuel injection rollers. The outer ring flanges support the cage against high inertia loads assuring positive, individual roller control by the cage.



Turntable Mounting

Cam followers can be mounted in a circular housing to support a ring or thrust plate. Precise leveling adjustment for the turntable can be obtained using the adjustable CamCentric™ cam follower.

Typical Applications

Cluster Mounting

Cluster mounting of four cam followers around a square column demonstrates the unique versatility of these bearings. Threads are concentric with the shank within very close limits. This feature is important on “blind hole” mountings where run-out would result in binding.

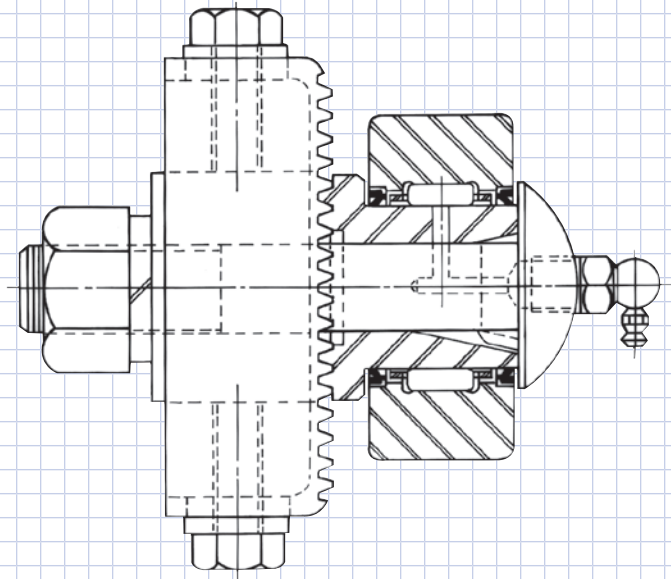
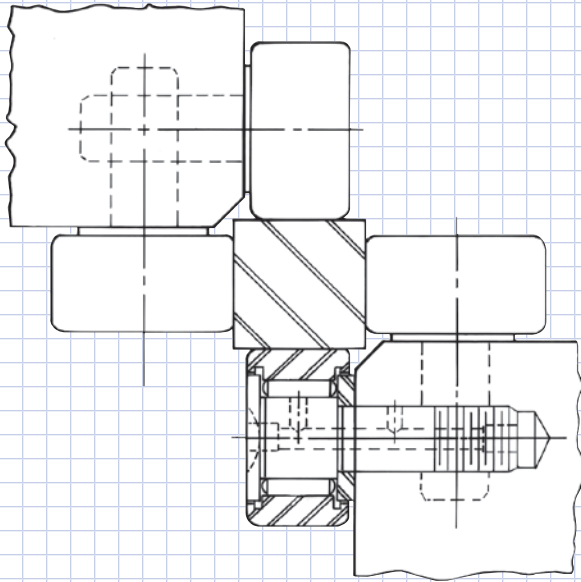

Textile Machinery

The sealed yoke rollers work extremely well as picking rolls of looms due to the fact that the minimum friction assures constant turning to eliminate wear.

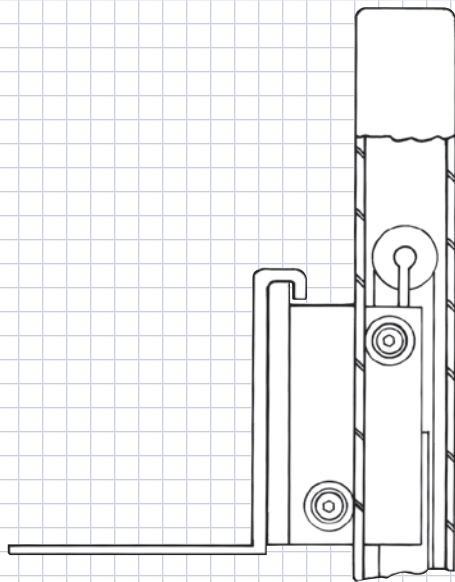

Manual Lift Truck

Schematic arrangement of cam followers is shown on the upright of a warehouse hand truck. CamCentric™ bearings are frequently used to provide adjustment so that all bearings contact the track without critical hole positioning.

UNIVERSAL SERIES™ INTERCHANGE TABLES



STANDARD STUD With Hex Socket Head — Sealed

RBC UNIVERSAL HexLube® Series	REPLACES Direct Interchange		REPLACES					
	McGill	Koyo	RBC		McGill		Koyo	
S16LW*	CF-1/2-SB	CRSB-8-1	S16	S16L	CF-1/2	CF-1/2-S	CR-8-1	CRS-8-1
S18LW*	CF-9/16-SB	—	S18	S18L	CF-9/16	CF-9/16-S	N/A	N/A
S20LW*	CF-5/8-SB	CRSB-10-1	S20	S20L	CF-5/8	CF-5/8-S	CR-10-1	CRS-10-1
S22LW*	CF-11/16-SB	—	S22	S22L	CF-1 1/16	CF-1 1/16-S	N/A	N/A
S24LW	CF-3/4-SB	CRSB-12	S24	S24L	CF-3/4	CF-3/4-S	CR-12	CRS-12
S28LW	CF-7/8-SB	CRSB-14	S28	S28L	CF-7/8	CF-7/8-S	CR-14	CRS-14
S32LW	CF-1-SB	CRSB-16	S32	S32L	CF-1	CF-1-S	CR-16	CRS-16
S36LW	CF-1 1/8-SB	CRSB-18	S36	S36L	CF-1 1/8	CF-1 1/8-S	CR-18	CRS-18
S40LW	CF-1 1/4-SB	CRSB-20	S40	S40L	CF-1 1/4	CF-1 1/4-S	CR-20	CRS-20
S44LW	CF-1 3/8-SB	CRSB-22	S44	S44L	CF-1 3/8	CF-1 3/8-S	CR-22	CRS-22
S48LW	CF-1 1/2-SB	CRSB-24	S48	S48L	CF-1 1/2	CF-1 1/2-S	CR-24	CRS-24
S52LW	CF-1 5/8-SB	CRSB-26	S52	S52L	CF-1 5/8	CF-1 5/8-S	CR-26	CRS-26
S56LW	CF-1 3/4-SB	CRSB-28	S56	S56L	CF-1 3/4	CF-1 3/4-S	CR-28	CRS-28
S60LW	CF-1 7/8-SB	CRSB-30	S60	S60L	CF-1 7/8	CF-1 7/8-S	CR-30	CRS-30
S64LW	CF-2-SB	CRSB-32	S64	S64L	CF-2	CF-2-S	CR-32	CRS-32
S72LW	CF-2 1/4-SB	CRSB-36	S72	S72L	CF-2 1/4	CF-2 1/4-S	CR-36	CRS-36
S80LW	CF-2 1/2-SB	CRSB-40	S80	S80L	CF-2 1/2	CF-2 1/2-S	CR-40	CRS-40
S88LW	CF-2 3/4-SB	CRSB-44	S88	S88L	CF-2 3/4	CF-2 3/4-S	CR-44	CRS-44
S96LW	CF-3-SB	CRSB-48	S96	S96L	CF-3	CF-3-S	CR-48	CRS-48
S104LW	CF-3 1/4-SB	CRSB-52	S104	S104L	CF-3 1/4	CF-3 1/4-S	CR-52	CRS-52
S112LW	CF-3 1/2-SB	CRSB-56	S112	S112L	CF-3 1/2	CF-3 1/2-S	CR-56	CRS-56
S128LW	CF-4-SB	CRSB-64	S128	S128L	CF-4	CF-4-S	CR-64	CRS-64
S160LW	CF-5-SB	CRSB-80	S160	S160L	CF-5	CF-5-S	CR-80	CRS-80
S192LW	CF-6-SB	CRSB-96	S192	S192L	CF-6	CF-6-S	CR-96	CRS-96

*Cannot be lubricated through hexhead

UNIVERSAL SERIES™ INTERCHANGE TABLES



STANDARD STUD

With Crowned Outer — Sealed — Hex Head

RBC UNIVERSAL HexLube® Series	REPLACES Direct Interchange		REPLACES		
	RBC Part No.	McGill	Koyo	RBC	McGill
CS16LW*	CCF-1/2-SB	CRSBC-8-1	CS16L	CCF-1/2-S	CRSC-8-1
CS18LW*	CCF-9/16-SB	—	CS18L	CCF-9/16-S	N/A
CS20LW*	CCF-5/8-SB	CRSBC-10-1	CS20L	CCF-5/8-S	CRSC-10-1
CS22LW*	CCF-11/16-SB	—	CS22L	CCF-11/16-S	N/A
CS24LW	CCF-3/4-SB	CRSBC-12	CS24L	CCF-3/4-S	CRSC-12
CS28LW	CCF-7/8-SB	CRSBC-14	CS28L	CCF-7/8-S	CRSC-14
CS32LW	CCF-1-SB	CRSBC-16	CS32L	CCF-1-S	CRSC-16
CS36LW	CCF-1 1/8-SB	CRSBC-18	CS36L	CCF-1 1/8-S	CRSC-18
CS40LW	CCF-1 1/4-SB	CRSBC-20	CS40L	CCF-1 1/4-S	CRSC-20
CS44LW	CCF-1 3/8-SB	CRSBC-22	CS44L	CCF-1 3/8-S	CRSC-22
CS48LW	CCF-1 1/2-SB	CRSBC-24	CS48L	CCF-1 1/2-S	CRSC-24
CS52LW	CCF-1 5/8-SB	CRSBC-26	CS52L	CCF-1 5/8-S	CRSC-26
CS56LW	CCF-1 3/4-SB	CRSBC-28	CS56L	CCF-1 3/4-S	CRSC-28
CS60LW	CCF-1 7/8-SB	CRSBC-30	CS60L	CCF-1 7/8-S	CRSC-30
CS64LW	CCF-2-SB	CRSBC-32	CS64L	CCF-2-S	CRSC-32
CS72LW	CCF-2 1/4-SB	CRSBC-36	CS72L	CCF-2 1/4-S	CRSC-36
CS80LW	CCF-2 1/2-SB	CRSBC-40	CS80L	CCF-2 1/2-S	CRSC-40
CS88LW	CCF-2 3/4-SB	CRSBC-44	CS88L	CCF-2 3/4-S	CRSC-44
CS96LW	CCF-3-SB	CRSBC-48	CS96L	CCF-3-S	CRSC-48
CS104LW	CCF-3 1/4-SB	CRSBC-52	CS104L	CCF-3 1/4-S	CRSC-52
CS112LW	CCF-3 1/2-SB	CRSBC-56	CS112L	CCF-3 1/2-S	CRSC-56
CS128LW	CCF-4-SB	CRSBC-64	CS128L	CCF-4-S	CRSC-64
CS160LW	CCF-5-SB	—	CS160L	CCF-5-S	—
CS192LW	CCF-6-SB	—	CS192L	CCF-6-S	—

*Cannot be lubricated through hexhead

UNIVERSAL SERIES™ INTERCHANGE TABLES



STANDARD STUD With Hex Socket Head Eccentric Bushing — Sealed

RBC UNIVERSAL HexLube® Series	REPLACES Direct Interchange	
	McGill	Koyo
RBC Part No.		
S16LWX*	CFE-1/2-SB	CRSBE-8-1
S18LWX*	CFE-9/16-SB	—
S20LWX*	CFE-5/8-SB	CRSBE-10-1
S22LWX*	CFE-11/16-SB	—
S24LWX	CFE-3/4-SB	CRSBE-12
S28LWX	CFE-7/8-SB	CRSBE-14
S32LWX	CFE-1-SB	CRSBE-16
S36LWX	CFE-1 1/8-SB	CRSBE-18
S40LWX	CFE-1 1/4-SB	CRSBE-20
S44LWX	CFE-1 3/8-SB	CRSBE-22
S48LWX	CFE-1 1/2-SB	CRSBE-24
S52LWX	CFE-1 5/8-SB	CRSBE-26
S56LWX	CFE-1 3/4-SB	CRSBE-28
S60LWX	CFE-1 7/8-SB	CRSBE-30
S64LWX	CFE-2 -SB	CRSBE-32
S72LWX	CFE-2 1/4-SB	CRSBE-36
S80LWX	CFE-2 1/2-SB	CRSBE-40
S88LWX	CFE-2 3/4-SB	CRSBE-44
S96LWX	CFE-3 -SB	CRSBE-48
S104LWX	CFE-3 1/4-SB	CRSBE-52
S112LWX	CFE-3 1/2-SB	CRSBE-56
S128LWX	CFE-4 -SB	CRSBE-64

STANDARD STUD With Hex Socket Head Crowned Outer Eccentric Bushing — Sealed

RBC UNIVERSAL HexLube® Series	REPLACES Direct Interchange	
	McGill	Koyo
RBC Part No.		
CS16LWX	CCFE-1/2-SB	CRSBCE-8-1
CS18LWX	CCFE-9/16-SB	—
CS20LWX	CCFE-5/8-SB	CRSBCE-10-1
CS22LWX	CCFE-11/16-SB	—
CS24LWX	CCFE-3/4-SB	CRSBCE-12
CS28LWX	CCFE-7/8-SB	CRSBCE-14
CS32LWX	CCFE-1-SB	CRSBCE-16
CS36LWX	CCFE-1 1/8-SB	CRSBCE-18
CS40LWX	CCFE-1 1/4-SB	CRSBCE-20
CS44LWX	CCFE-1 3/8-SB	CRSBCE-22
CS48LWX	CCFE-1 1/2-SB	CRSBCE-24
CS52LWX	CCFE-1 5/8-SB	CRSBCE-26
CS56LWX	CCFE-1 3/4-SB	CRSBCE-28
CS60LWX	CCFE-1 7/8-SB	CRSBCE-30
CS64LWX	CCFE-2-SB	CRSBCE-32
CS72LWX	CCFE-2 1/4-SB	CRSBCE-36
CS80LWX	CCFE-2 1/2-SB	CRSBCE-40
CS88LWX	CCFE-2 3/4-SB	CRSBCE-44
CS96LWX	CCFE-3-SB	CRSBCE-48
CS104LWX	CCFE-3 1/4-SB	CRSBCE-52
CS112LWX	CCFE-3 1/2-SB	CRSBCE-56
CS128LWX	CCFE-4-SB	CRSBCE-64

*Cannot be lubricated through hexhead

UNIVERSAL SERIES™ INTERCHANGE TABLES



HEAVY STUD With Hex Socket Head — Sealed

RBC UNIVERSAL HexLube® Series	REPLACES Direct Interchange		REPLACES				
	RBC Part No.	McGill	Koyo	RBC		McGill	Koyo
H16LW*	CFH-1/2-SB	CRHSB-8-1	H16	H16L	CFH-1/2	CFH-1/2-S	CRH-8-1
H18LW*	CFH-9/16-SB	N/A	H18	H18L	CFH-9/16	CFH-9/16-S	N/A
H20LW*	CFH-5/8-SB	CRHSB-10-1	H20	H20L	CFH-5/8	CFH-5/8-S	CRH-10-1
H22LW*	CFH-11/16-SB	N/A	H22	H22L	CFH-11/16	CFH-11/16-S	N/A
H24LW	CFH-3/4-SB	CRHSB-12	H24	H24L	CFH-3/4	CFH-3/4-S	CRH-12
H28LW	CFH-7/8-SB	CRHSB-14	H28	H28L	CFH-7/8	CFH-7/8-S	CRH-14
H32LW	CFH-1-SB	CRHSB-16	H32	H32L	CFH-1	CFH-1-S	CRH-16
H36LW	CFH-1 1/8-SB	CRHSB-18	H36	H36L	CFH-1 1/8	CFH-1 1/8-S	CRH-18
H40LW	CFH-1 1/4-SB	CRHSB-20	H40	H40L	CFH-1 1/4	CFH-1 1/4-S	CRH-20
H44LW	CFH-1 3/8-SB	CRHSB-22	H44	H44L	CFH-1 3/8	CFH-1 3/8-S	CRH-22
H48LW	CFH-1 1/2-SB	CRHSB-24	H48	H48L	CFH-1 1/2	CFH-1 1/2-S	CRH-24
H52LW	CFH-1 5/8-SB	CRHSB-26	H52	H52L	CFH-1 5/8	CFH-1 5/8-S	CRH-26
H56LW	CFH-1 3/4-SB	CRHSB-28	H56	H56L	CFH-1 3/4	CFH-1 3/4-S	CRH-28
H60LW	CFH-1 7/8-SB	CRHSB-30	H60	H60L	CFH-1 7/8	CFH-1 7/8-S	CRH-30
H64LW	CFH-2 -SB	CRHSB-32	H64	H64L	CFH-2	CFH-2-S	CRH-32
H72LW	CFH-2 1/4-SB	CRHSB-36	H72	H72L	CFH-2 1/4	CFH-2 1/4-S	CRH-36
H80LW	CFH-2 1/2-SB	CRHSB-40	H80	H80L	CFH-2 1/2	CFH-2 1/2-S	CRH-40
H88LW	CFH-2 3/4-SB	CRHSB-44	H88	H88L	CFH-2 3/4	CFH-2 3/4-S	CRH-44
H96LW	CFH-3 -SB	CRHSB-48	H96	H96L	CFH-3	CFH-3-S	CRH-48
H104LW	CFH-3 1/4-SB	CRHSB-52	H104	H104L	CFH-3 1/4	CFH-3 1/4-S	CRH-52
H112LW	CFH-3 1/2-SB	CRHSB-56	H112	H112L	CFH-3 1/2	CFH-3 1/2-S	CRH-56
H128LW	CFH-4 -SB	CRHSB-64	H128	H128	CFH-4	CFH-4S	CRH-64
H160LW	CFH-5 -SB	N/A	N/A	N/A	N/A	N/A	N/A
H192LW	CFH-6 -SB	N/A	N/A	N/A	N/A	N/A	N/A
H224LW	CFH-7 -SB	N/A	N/A	N/A	N/A	N/A	N/A

*Cannot be lubricated through hexhead

UNIVERSAL SERIES™ INTERCHANGE TABLES



HEAVY STUD

With Crowned Outer — Sealed — Hex Head

RBC UNIVERSAL HexLube® Series	REPLACES Direct Interchange		REPLACES		
	RBC Part No.	McGill	Koyo	RBC	McGill
CH16LW*	CCFH-1/2-SB	N/A	CH16L	CCFH-1/2-S	N/A
CH18LW*	CCFH-9/16-SB	N/A	CH18L	CCFH-9/16-S	N/A
CH20LW*	CCFH-5/8-SB	N/A	CH20L	CCFH-5/8-S	CRHSC-10-1
CH22LW*	CCFH-11/16-SB	N/A	CH22L	CCFH-11/16-S	N/A
CH24LW	CCFH-3/4-SB	N/A	CH24L	CCFH-3/4-S	CRHSC-12
CH28LW	CCFH-7/8-SB	N/A	CH28L	CCFH-7/8-S	N/A
CH32LW	CCFH-1-SB	N/A	CH32L	CCFH-1-S	CRHSC-16
CH36LW	CCFH-1 1/8-SB	N/A	CH36L	CCFH-1 1/8-S	CRHSC-18
CH40LW	CCFH-1 1/4-SB	N/A	CH40L	CCFH-1 1/4-S	CRHSC-20
CH44LW	CCFH-1 3/8-SB	N/A	CH44L	CCFH-1 3/8-S	N/A
CH48LW	CCFH-1 1/2-SB	N/A	CH48L	CCFH-1 1/2-S	N/A
CH52LW	CCFH-1 5/8-SB	N/A	CH52L	CCFH-1 5/8-S	N/A
CH56LW	CCFH-1 3/4-SB	N/A	CH56L	CCFH-1 3/4-S	CRHSC-28
CH60LW	CCFH-1 7/8-SB	N/A	CH60L	CCFH-1 7/8-S	N/A
CH64LW	CCFH-2-SB	N/A	CH64L	CCFH-2-S	CRHSC-32
CH72LW	CCFH-2 1/4-SB	N/A	CH72L	CCFH-2 1/4-S	N/A
CH80LW	CCFH-2 1/2-SB	N/A	CH80L	CCFH-2 1/2-S	CRHSC-40
CH88LW	CCFH-2 3/4-SB	N/A	CH88L	CCFH-2 3/4-S	N/A
CH96LW	CCFH-3-SB	N/A	CH96L	CCFH-3S	CRHSC-48
CH104LW	CCFH-3 1/4-SB	N/A	CH104L	CCFH3 1/4-S	N/A
CH112LW	CCFH-3 1/2-SB	N/A	CH112L	CCFH-3 1/2-S	N/A
CH128LW	CCFH-4-SB	N/A	CH128L	CCFH-4-S	N/A
CH160LW	CCFH-5-SB	N/A	CH160L	CCFH-5-S	N/A
CH192LW	CCFH-6-SB	N/A	CH192L	CCFH-6-S	N/A

*Cannot be lubricated through hexhead

UNIVERSAL SERIES™ INTERCHANGE TABLES



YOKE ROLLER Sealed

RBC UNIVERSAL Series	REPLACES Direct Interchange		REPLACES		
	RBC Part No.	McGill	Koyo	RBC	McGill
Y24L	CYR-3/4-S	YCRS-12	Y24	CYR3/4	YCR12
Y28L	CYR-7/8-S	YCRS-14	Y28	CYR7/8	YCR14
Y32L	CYR-1-S	YCRS-16	Y32	CYR1	YCR16
Y36L	CYR-1 1/8-S	YCRS-18	Y36	CYR1 1/8	YCR18
Y40L	CYR-1 1/4-S	YCRS-20	Y40	CYR1 1/4	YCR20
Y44L	CYR-1 3/8-S	YCRS-22	Y44	CYR1 3/8	YCR22
Y48L	CYR-1 1/2-S	YCRS-24	Y48	CYR1 1/2	YCR24
Y52L	CYR-1 5/8-S	YCRS-26	Y52	CYR1 5/8	YCR26
Y56L	CYR-1 3/4-S	YCRS-28	Y56	CYR1 3/4	YCR28
Y60L	CYR-1 7/8-S	YCRS-30	Y60	CYR1 7/8	YCR30
Y64L	CYR-2-S	YCRS-32	Y64	CYR2	YCR32
Y72L	CYR-2 1/4-S	YCRS-36	Y72	CYR2 1/4	YCR36
Y80L	CYR-2 1/2-S	YCRS-40	Y80	CYR2 1/2	YCR40
Y88L	CYR-2 3/4-S	YCRS-44	Y88	CYR2 3/4	YCR44
Y96L	CYR-3-S	YCRS-48	Y96	CYR3	YCR48
Y104L	CYR-3 1/4-S	YCRS-52	Y104	CYR3 1/4	YCR52
Y112L	CYR-3 1/2-S	YCRS-56	Y112	CYR3 1/2	YCR56
Y128L	CYR-4-S	YCRS-64	Y128	CYR4	YCR64
Y160L	CYR-5-S	YCRS-80	N/A	N/A	N/A
Y192L	CYR-6-S	YCRS-96	N/A	N/A	N/A
Y224L	CYR-7-S	YCRS-112	N/A	N/A	N/A



YOKE ROLLER

Crowned Outer — Sealed

RBC UNIVERSAL Series	REPLACES Direct Interchange	
	McGill	Koyo
RBC Part No.		
CY24L	CCYR-3/4-S	YCRSC-12
CY28L	CCYR-7/8-S	YCRSC-14
CY32L	CCYR-1-S	YCRSC-16
CY36L	CCYR-1 1/8-S	YCRSC-18
CY40L	CCYR-1 1/4-S	YCRSC-20
CY44L	CCYR-1 3/8-S	YCRSC-22
CY48L	CCYR-1 1/2-S	YCRSC-24
CY52L	CCYR-1 5/8-S	YCRSC-26
CY56L	CCYR-1 3/4-S	YCRSC-28
CY60L	CCYR-1 7/8-S	YCRSC-30
CY64L	CCYR-2 -S	YCRSC-32
CY72L	CCYR-2 1/4-S	YCRSC-36
CY80L	CCYR-2 1/2-S	YCRSC-40
CY88L	CCYR-2 3/4-S	YCRSC-44
CY96L	CCYR-3-S	YCRSC-48
CY104L	CCYR-3 1/4-S	YCRSC-52
CY112L	CCYR-3 1/2-S	YCRSC-56
CY128L	CCYR-4-S	YCRSC-64
CY160L	CCYR-5-S	YCRSC-80
CY192L	CCYR-6-S	YCRSC-96
CY224L	CCYR-7-S	YCRSC-112

CUSTOM DESIGNED CAM FOLLOWERS

In addition to our complete line of standard cam followers, RBC also will manufacture many other cam followers of a highly specialized nature for specific applications. As each special cam follower is engineered for a particular set of operating conditions, it is essential that we have complete data regarding the application, including potential production volumes.

Shown below are just a few of our custom designed cam followers.



**Special Stud Configuration
with Mounting Notch**



**Special Yoke with
Integrating Mounting Plate**



**Triple Row Special Outer Ring
Configuration Yoke Roller**



**Stainless Steel Outer,
TDC Plated Stud**



Double Outer Cam Follower

RBC Bearings® has been producing bearings in the USA since 1919. In addition to unique custom bearings, RBC Bearings® offers a full line of standard industrial and aerospace bearings, including:



Tapered Roller Thrust Bearings

Case-hardened tapered roller thrust bearings for oilfield top drives and swivels. Available in full complement, maximum capacity versions.



Thin Section Ball Bearings

Standard cross sections to one inch. Bore sizes to 40 inches. Stainless steel and other materials are available. Seals are available on all sizes and standard cross sections. Super duplex configurations.



Cam Followers

Standard stud, heavy stud, yoke type, caged roller followers. Patented RBC Roller® cylindrical roller cam followers, HexLube® universal cam followers, airframe track rollers.



Cylindrical Roller Bearings

Cylindrical roller bearings designed for mud pump pinion and eccentric positions. Fully interchangeable to industry standards.



Needle Roller Bearings

Pitchline® caged heavy duty needle roller bearings ideal for cross head bearings applications. These double row bearings are available in single row and TandemRoller® versions.



Commercial Rod Ends

Commercial and industrial, precision, Mil-Spec series, self-lubricating, and aircraft. Sold under the Heim®, Unibal®, and Spherco® names. Available in inch and metric sizes.

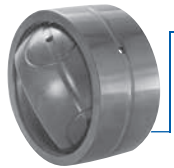

Spherical Plain Bearings

Radial, angular contact, extended inner ring, high misalignment. QuadLube®, ImpactTuff®, SpreadLock® Seal, CrossLube®, DuraLube™, and self-lubricating bearings. Available in inch and metric sizes.



Tapered Roller Bearings

Single, double, & multi row versions available for main bearing positions in mud pumps, gear boxes, etc. Bearings are constructed of case hardened steel washers and rollers with bore size of 11" or greater.



TP Series Bearings

RBC Bearings® TP Series cylindrical roller thrust bearings ideal for crane hooks, oil well swivels, winch systems, and gear boxes. Fully interchangeable with industry standard offering.



Keyless Locking Devices

Mechanical bushings used to connect power transmission components onto rotating shafts. Without the use of keyways, KLDs eliminate the problems associated with backlash including fretting, corroding, and wallowing.



Lubron® Bearings

Lubron® self-lubricating bearings designed and custom manufactured in most any size, material and bearing configuration. Applications include hydro power and water control, nuclear power generation, infrastructure, architecture, offshore marine, industrial, machinery and heavy equipment.



Shaft Collars

Used to position or locate a component on a shaft. Made from mild steel, type 303 or 316 stainless steel, aluminum, or acetal. Available in inch and metric sizes.



Self-Lubricating Bearings

Radial, thrust, rod ends, spherical bearings, high temperature, high loads. Available in inch and metric sizes. Fiberglide® self-lubricating bearings.



Rigid Couplings

Shaft couplings serve as components to time, join, or align shafts at lower speeds and torque, especially when zero backlash is desired. Made from mild steel with a black oxide finish type 303 stainless steel, or aluminum. Available in inch and metric sizes.



Specials

RBC Bearings® manufactures many specialty bearings for the aerospace, oil and energy, semiconductor equipment, packaging, transportation, and other industries.



Ball Bearings

Precision ground, semiground, unground. High loads, long life, smooth operation. Nice® branded products are offered in caged and full complement configurations.



PIC Design®

Complete line of precision gears, precision hardware, timing belts, pulleys, and linear motion systems. Industries served include industrial, aerospace, defense, medical, robotics and automation, material handling, and assembly. Custom design support for unique applications.

