

M81935/4 SELF-LUBRICATED ROD END BEARINGS

AS81935/4 • AS81935 (formerly MIL-B-81935)

- Male type, rod end
- High temperature — low wear
-65°F to +325°F (-53.9°C to +162.8°C)
- Material: Bearing inner ring: CRES 440C
Bearing outer ring: CRES 17-4PH
Rod end housing: AISI 4340 steel heat treated to 180,000 psi min. tensile strength. Exposed surface of rod end housing cadmium plated
- Liner: Fibriloid® or “E” Uniflon® qualified to AS81820
- Rolled threads conform to UNJF-3A per AS8879
For rod ends with left hand thread add “L” or “1” depending on part number ordered. Example: see below
- For rod ends with slotted shank or “keyway” add “K” or “1” Example: see below

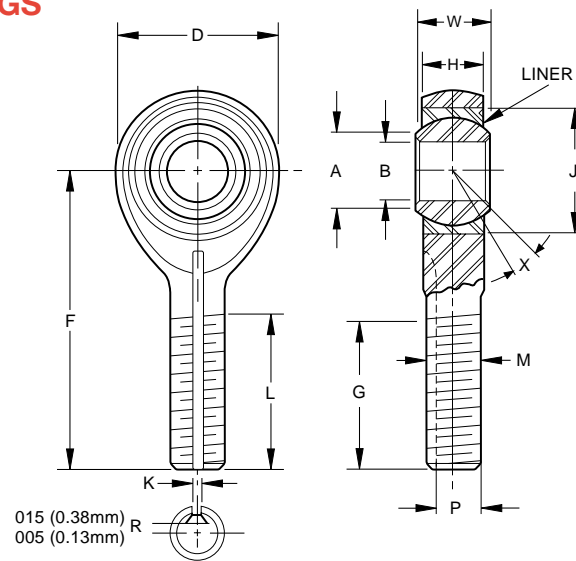

SPECIFICATIONS AND ORDERING INFORMATION

DIMENSIONS – TOLERANCES

PART NUMBERS		B		D		L		F		W		H		A		J		G		K ⁽¹⁾		P ⁽¹⁾		M		X°	
ME-AN Dash No.	M81935/4 Dash No.	+0.000, -0.0005 +0.00, -0.013	±0.010 +0.25	±0.031 ±.79	±0.010 +0.25	+0.000, -0.002 +0.00, -0.05	±0.005 +0.13	Min.	Max.	Min.	Max.	Min.	Max.	Min.	Max.	Min.	Max.	Min.	Max.	Min.	Max.	Min.	Max.	UNJF-3A PER AS8879	Min.	Max.	
		in.	mm	in.	mm	in.	mm	in.	mm	in.	mm	in.	mm	in.	mm	in.	mm	in.	mm	in.	mm	in.	mm				
03	-03	.1900	4.826	.680	17.27	.775	19.69	1.315	33.40	.281	7.14	.228	5.79	.293	7.44	.6250	15.875	.896	22.76	.062	1.57	.207	5.26	1/4-28	10		
04	-04	.2500	6.350	.827	21.01	.775	19.69	1.443	36.65	.343	8.71	.260	6.60	.364	9.25	.6250	15.875	.896	22.76	.062	1.57	.207	5.26	1/4-28	10		
05	-05	.3125	7.938	.984	24.99	1.187	30.15	1.948	49.48	.375	9.53	.291	7.39	.419	10.64	.6875	17.462	1.308	33.22	.062	1.57	.268	6.81	5/16-24	10		
06	-06	.3750	9.525	1.131	28.73	1.187	30.15	2.030	51.56	.406	10.31	.322	8.18	.475	12.07	.8125	20.638	1.308	33.22	.093	2.36	.319	8.10	3/8-24	9		
07	-07	.4375	11.112	1.294	32.87	1.281	32.54	2.250	57.15	.437	11.10	.353	8.97	.530	13.46	.9062	23.017	1.402	35.61	.093	2.36	.383	9.73	7/16-20	8		
08	-08	.5000	12.700	1.459	37.06	1.462	37.13	2.544	64.62	.500	12.70	.400	10.16	.600	15.24	1.0000	25.400	1.589	40.36	.093	2.36	.445	11.30	1/2-20	8		
10	-10	.6250	15.875	1.763	44.78	1.582	40.18	2.832	71.93	.625	15.88	.510	12.95	.739	18.77	1.1875	30.162	1.683	42.75	.125	3.18	.541	13.74	5/8-18	8		
12	-12	.7500	19.050	2.140	54.36	1.687	42.85	3.193	81.10	.750	19.05	.603	15.32	.920	23.37	1.3750	34.925	1.808	45.92	.125	3.18	.663	16.84	3/4-16	8		
14	-14	.8750	22.225	2.372	60.25	2.000	50.80	3.677	93.40	.875	22.23	.713	18.11	.980	24.89	1.6250	41.275	2.121	53.87	.156	3.96	.777	19.74	7/8-14	8		
16	-16	1.0000	25.400	2.681	68.10	2.100	53.34	3.988	101.30	1.000	25.40	.807	20.50	1.118	28.40	2.1250	53.975	2.221	56.41	.156	3.96	.900	22.86	1-12	9		

⁽¹⁾Keyway when specified, is compatible with locking devices, AS81935/3 for sizes 3 thru 8, and NAS559 for sizes 10 thru 16.

Keyway tolerances not specified shall be in accordance with AS81935/3 or NAS513 as applicable.

LOAD RATINGS

PART NUMBERS		Ultimate Static Radial Load		Fatigue Load		Axial Proof Load		Approx. Weight		No Load Rational Breakaway Torque			
ME-AN Dash No.	M81935/4 Dash No.	lb.	N	lb.	N	lb.	N	lbs.	kg	Min.		Max.	
		in.-lbs.	Nm	in.-lbs.	Nm	in.-lbs.	Nm	in.-lbs.	Nm	in.-lbs.	Nm	in.-lbs.	Nm
03	-03	3000	13320	1100	4884	150	666	0.038	0.017	0.5	0.06	6	0.68
04	-04	5300	23532	1500	6660	430	1909	0.045	0.020	0.5	0.06	6	0.68
05	-05	8600	38184	2400	10656	700	3108	0.081	0.037	1	0.11	15	1.70
06	-06	13000	57720	3600	15984	1100	4884	0.120	0.055	1	0.11	15	1.70
07	-07	17800	79032	5000	22200	1400	6216	0.172	0.078	1	0.11	15	1.70
08	-08	24200	107448	6800	30192	2040	9058	0.254	0.115	1	0.11	15	1.70
10	-10	38500	170940	10800	47952	2430	10789	0.455	0.207	1	0.11	15	1.70
12	-12	56600	251304	16000	71040	2940	13054	0.774	0.352	1	0.11	15	1.70
14	-14	77400	343656	21900	97236	3190	14164	1.141	0.519	1	0.11	24	2.71
16	-16	101400	450216	28600	126984	3570	15851	1.646	0.748	1	0.11	24	2.71

⁽¹⁾Based on bolt bending fatigue strength 180000 psi

⁽²⁾Based on bolt bending fatigue strength 127kg/mm².

⁽³⁾Shank limitation

Notes: For liner specifications or the following options:

- Stainless steel rod end body
- High temperature or high speed liners

Please see engineering section or contact RBC Aerospace Bearings.

Bearing configuration	Part number designations for a 0.2500 in. bore rod end	
Base P/N (no options)	ME4AN	M81935/4-4
Keyway on threads	MEK4AN	M81935/4-4K
Left hand thread	MEL4AN	M81935/4-4L