

Fiberglide®/Fabroid®

Self-Lubricating Bearings

World Leader in Self-Lubricating Liner Systems™



**Featuring the highest load capacity
maintenance-free bearings in the Industry**

RBC[®]
BEARINGS

www.rcbearings.com
800.390.3300



RBC Bearings Incorporated (RBC Bearings, RBC) has had a long tradition of innovation, commitment, and quality since the company was founded in 1919. Today, RBC Bearings has grown into a world-class manufacturer of standard and custom-engineered bearings and related products, with a product focus on research, testing, and development of the best product for specific applications.

What We Manufacture

RBC Bearings, with facilities throughout North America and Europe, provides bearings and precision products for applications in the construction, mining, material handling, transportation and off-highway equipment, robotics and automation, farming, machine tool, and semiconductor equipment industries. Through RBC Aerospace Bearings, the company is a major manufacturer of highly-engineered bearings and precision products for military, defense, and commercial aerospace applications.

RBC's high-quality bearings include:

- **Heavy Duty Needle Roller Bearings** - Pitchlign® caged heavy duty needle roller bearings, inner rings, type TJ TandemRoller® bearings for long life.
- **Spherical Plain Bearings** - Radial, angular, contact, high misalignment, extended inner ring, DuraLube™ maintenance-free spherical plain bearings, QuadLube® long life bearings, ImpactTuff® case carburized bearings, ShimPack® double-acting angular contact bearings, CrossLube® lubrication groove systems, and SpreadLock® Seal.
- **Cam Followers and Yoke Rollers** - Standard stud, heavy stud, yoke type, caged roller followers, RBC Roller® long life cam followers, HexLube® universal cam followers, airframe track rollers. Mastguide rollers and carriage rollers, chain sheaves (for leaf chain), toothless sprockets (for roller chain), and heavy-duty roller bearing construction.
- **Rod Ends** - Commercial and aerospace, precision, Mil-Spec series, self-lubricating, inch and metric. Heim®, Unibal®, and Spherco® brands.
- **Self-Lubricating Bearings** - Radial, thrust, rod ends, spherical plain bearings, high temperature, high loads, inch and metric. Fiberglide®/Fabroid® brand.
- **Thin Section Ball Bearings** - Standard cross sections to one inch. Sizes to 40 inches. Stainless steel and other materials available. Seals available on all sizes and standard cross sections.
- **Airframe Control Bearings** - Ball bearing types, self-lubricating types, needle rollers, track rollers.
- **Ground, Semiground, and Unground Ball Bearings** - Full complement, utilizes design and burnished races for higher loads, long life, and smooth operation.
- **Dowel Pins, Loose Needle Rollers, Shafts**
- **Tapered Roller and Tapered Thrust Bearings** - Case-hardened and through-hardened in a variety of sizes, used in Class 8 heavy truck and trailer wheel bearings, final drive transmissions and gear boxes.
- **Custom Designed Bearings** - RBC produces a wide range of custom bearings in various materials for specific applications.

Fiberglide®/Fabroid® Self-Lubricating Technology

RBC Bearings is the world leader in self-lubricating technology with our patented Fiberglide® and Fabroid® liner systems. We produce a broad line of standard inch and metric self-lubricating bearings in journal, thrust, and spherical configurations. This unique bearing product offers the user design freedom as well as cost benefits from its "maintenance free" characteristics. The product is suited for applications where normal lubrication is difficult or costly. Fiberglide®/Fabroid® products can also be used where non-lubricating fluids might be present.

In addition to the standard self-lubricating products, RBC Bearings offers specials for applications such as formed tracks and guideways, earthquake mounts for buildings and bridges, and ball joint socket liners. We also have a "Bond Only" service available. We will bond our self-lubricating liner systems to your parts. This provides an integral liner system, that offers adequate lubrication, low friction, high load capacity, and a wide operating temperature range. Consult with your local RBC Bearings sales engineer for assistance with your specific requirements.

How We Can Serve You

RBC Bearings has implemented a total quality control system that uses statistical quality control at all facilities, and manufactures in high volume to a just-in-time program.

To serve the ongoing needs of customers, RBC Bearings has a global network of over 1,600 distributors, sales engineers, and authorized agents. For assistance with your bearing application, contact:

Customer Service — 800.390.3300

Warranty

RBC Bearings products are warranted for material and workmanship for a period not to exceed 90 days from shipment and for a value not to exceed purchase price. No other warranty is in effect.

Disclaimer and Intellectual Property Statement











The materials comprising this Catalog are provided by RBC Bearings as a service to its customers on an "as-is" basis for informational purposes only. RBC assumes no responsibility for any errors or omissions in these materials. RBC makes no commitment to update the information contained herein.

RBC makes no, and expressly disclaims any, representations or warranties, express or implied, regarding the Catalog, including, without limitation, any implied warranties of merchantability or fitness for a particular purpose. RBC makes no, and expressly disclaims any, warranties, express or implied, regarding the correctness, accuracy, completeness, timeliness, and reliability of the text, graphics and any other items in the Catalog. Under no circumstances shall RBC, its affiliates, or any of their respective partners, officers, directors, employees, agents or representatives be liable for any damages, whether direct, indirect, special or consequential damages for lost revenues, lost profits, or otherwise, arising from or in connection with this Catalog and the materials contained herein.

All materials contained in the Catalog are protected by copyright laws, and may not be reproduced, republished, distributed, transmitted, displayed, broadcast or otherwise exploited in any manner without the express prior written permission of RBC.





RBC's names and logos and all related trademarks (including RBC Part Numbers, Series Number, and Cone and Cup Numbers), trade names, and other intellectual property are the property of RBC Bearings and cannot be used without its express prior written permission.

RBC
BEARINGS
TABLE OF CONTENTS

Selection Guide	2	
Fiberglide®/Fabroid® Bearings—Product Overview	3	
Series CJS-Journal Bearing Type—Coiled Steel Backing	4	
Series CJM-Metric Sized Journal Bearings—Coiled Steel Backing	6	
Series CJT-Journal Bearing Type—Thin Walled Steel Backing	8	
Series CJH-Journal Bearing Type—Heavy Walled Steel Backing	10	
Series LJS-Journal Bearing Liner Type—Non-Metallic	11	
Series SJS Solid Journal Bearing	12	
Series LTD-Thrust Washer—Non-Metallic	13	
Series FTS-Thrust Washer—Steel Backing	14	
Series FTM Single Sided Metal Backed Metric	15	
Series FTP Slim Pack Thrust Bearing	16	
Self-Lubricated Spherical Bearings	17	
Fiberglide®/Fabroid® Bearings—Engineering	19	
Fiberglide®/Fabroid® Bearings—Comparative Testing Results	21	
Fiberglide®/Fabroid® Bearings—Installation	23	

SELECTION GUIDE

SELF-LUBRICATING, MAINTENANCE-FREE BEARINGS

TYPE	DESCRIPTION	DIMENSIONS	APPLICATIONS
	CJS Journal bearings, split seam steel backing, zinc plated	Nom. shaft diameter-.375 to 7.000 Bearing length-.250 to 6.500	The CJS bearing works excellent in any pivot or linkage application. For construction and farm equipment, this product is typically used in kingpins, rock shafts, differentials, hinges, pedals and many other pivot points.
	CJM Metric Journal bearings, split seam steel backing, zinc plated	Nom. shaft diameter-8MM to 120MM Bearing length-8MM to 165MM	This product is the metric equivalent to the CJS product and used in similar applications.
	CJT Journal bearings, thin walled, split seam steel backing, zinc plated	Nom. shaft diameter-.500 to 7.000 Bearing length-.375 to 6.000	This bearing is designed as a direct replacement with conventional 1/16" wall bushings. These bearings are used in self-lubricated chain, variable speed sheaves, boom pivot points on fork lifts and many similar applications.
	CJH Journal bearings, heavy walled, split seam steel backing, zinc plated	Nom. shaft diameter-.750 to 7.000 Bearing length-.250 to 6.500	This bearing is designed as a direct replacement with the conventional 1/8" wall bronze bushings. Typical applications include suspension points on large trucks and railroad cars. These products are also used in the boom foot pivot of large cranes.
	LJS Journal bearings, liner type, non-metallic	Nom. shaft diameter-1.000 to 12.000 Bearing length-.375 to 6.500	These bearings are used in many harsh applications and in food handling machinery. Typical applications include butterfly valves and trunnion support pivots. This product is also used in sheaves and hoists for marine applications.
	SJS Solid, machined journal bearing, metal backed	Nom. shaft diameter-.500 to 5.000 Bearing length-1.000 - 4.000	Ideal for construction, farm, and material handling equipment, especially where tight tolerances are necessary.
	LTD Thrust bearings, laminated phenolic-backed, double-sided	Nom. shaft diameter-.250 to 3.250 I.D. - .280 to 3.312 O.D. - .500 to 4.875	These bearings are used in cam actuator arms, turntable support bearings, exercise equipment, truck differentials and many other applications.
	FTS Thrust bearings, metal-backed, single sided	Nom. shaft diameter-.250 to 3.250 I.D. - .280 to 3.312 O.D. - .500 to 4.875	These bearings accommodate thrust in clutches, hospital beds, screw jacks, valve actuators, vehicle suspensions, and many other applications.
	FTP Thrust packs, Two piece assembly	Nom. shaft diameter-I.D. - 1.000 to 3.000 O.D. - 1.750 to 4.625	These bearings are used in articulated frame joints, pivot arm supports, kingpins and many other applications.
	Self-Lubricated Spherical Bearing Swaged and equipped with self-lubricating liner system to reduce friction.	Nom. shaft diameter-.190 to 1.000 Bearing length-.281 to 1.375	Used in hydraulic cylinder and actuators as well as control linkages.

PRODUCT OVERVIEW

SELF-LUBRICATING BEARINGS

Fiberglide®/Fabroid® bearings offer 18 distinct advantages over conventional lubricated bearings:

1. Design freedom—**Fiberglide®/Fabroid®** bearings can be incorporated into internal component assemblies inaccessible to conventional lubrication technique, eliminating costly maintenance tear down.
2. Maintenance free—The self-lubricating nature of **Fiberglide®/Fabroid®** makes it an ideal selection for equipment providing service to remote environments such as oil and gas transmission lines and pumping stations.
3. Operation without lubrication while tolerating many lubricating and non-lubricating fluids.
4. Environmentally friendly, lead-free, green product.
5. High dynamic load-carrying (up to 20,000 psi).
6. Inherent vibration and noise dampening qualities.
7. Low coefficient of friction.
8. Freedom from stick-slip.
9. Absence of cold-flow tendencies of solid and filled PTFE resins.
10. High resistance to fatigue under shock loads.
11. Eliminating fretting corrosion.
12. Resistant to attack by most substances.
13. Operation at temperatures beyond the range of most lubricants (-320°F to 400°F).
14. **Fiberglide®** bearings have been tested to have 7-10 times the life of a DU® Product, see chart on page 22.
15. Good dimensional stability.
16. Compatible with a wide range of mating materials.
17. Electrically non-conducting.
18. Non-magnetic.

TYPICAL APPLICATIONS

Fiberglide®/Fabroid® bearings are being used by many basic manufacturing industries where they have proven their economy, convenience, and dependability.

- Aerial Work Platforms
- Steering systems for trucks, farm tractors, off-highway equipment
- Heavy-duty suspension systems of trucks, tractors and related equipment
- Brakes for trucks, automobiles, off-road vehicles
- Transmission shift linkages and pivots
- Butterfly, ball plug valves
- Clutches and variable speed sheaves
- Marine equipment
- Pneumatic and hydraulic tools and actuators
- Conveying and material handling equipment
- Recreational vehicle suspension and controls
- Packaging machinery
- Textile machinery
- Wherever heavy loading and low speed oscillations are encountered

Fiberglide®/Fabroid® is a proprietary self-lubricating bearing material of woven polytetrafluoroethylene or PTFE fibers applied to a rigid backing. To assure the best possible bond between PTFE fibers and backing material, a secondary, more readily bondable fiber (which may vary with application requirements) is interwoven with the PTFE fibers presented on the bearing side of the fabric.

Fiberglide®/Fabroid® bearings are unique in their ability to resist coldflow under extremely high loads because the monofilament fibers have a tensile strength approximately 25 times greater than straight PTFE resins. Cold flow is also minimized by the effective entrapment of the fiber bundles by the high-strength bonding resins.

Fiberglide®/Fabroid® bearings are completely self-lubricating and normally run dry. However, they can also be used where lubricating or other fluids are present. Operating dry, **Fiberglide®/Fabroid®** bearings are recommended where low surface speeds are combined with high loads.

Fiberglide®/Fabroid® bearings are available with many backing materials in a wide variety of standard configurations. In addition, Transport Dynamics offers special bearings with an almost unlimited range of configurations and metal backings.

Fabroid® liners are designed to carry higher loads with improved wear life. **Fabroid®** liner types are woven PTFE glass fabrics utilizing various thermoset resins depending on product type. This construction leaves the PTFE fibers exposed on the working surface without contact to the resin. A resin is used in the prepreg and as the bonding adhesive. Due to the construction, the liner is highly compressible and able to absorb distortions in mating surfaces, and has a low friction surface from the start with no break in period.

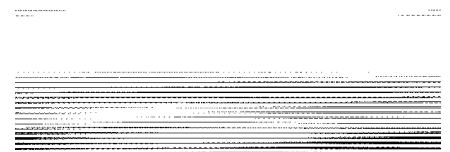

*Construction of typical
Fiberglide®/Fabroid® bearing:*

1. PTFE fabric
2. Adhesive bonding agent
3. Metal



Fiberglide® split seam steel journal bearings are designed to meet or exceed industry standards for self-lubricating bushings. They provide all of the advantages of Fiberglide® at minimum cost. Carbon steel is normally used as a backing material, with the external surfaces plated to resist corrosion. Other metals can be supplied upon special order. Typical applications include aerial work platform automotive vehicles, farm equipment, construction and material handling equipment. Fabroid® can also be supplied for special applications — consult Transport Dynamics engineering department. For bearing installation, see page 23.

STANDARD INCH SERIES

PART NUMBER	RECOMMENDED SHAFT DIAMETER MIN/MAX (in.)	RECOMMENDED* HOUSING BORE MIN/MAX (in.)	BEARING LENGTH +.000-.020 (in.)	WALL THICKNESS (in.) REF	MAX STATIC LOAD (lbf)	BEARING WEIGHT (lbs)
CJS0606	.3736/.3750		.375		5,344	0.006
CJS0608	.3736/.3750	.4680/.4690	.500	.047	7,125	0.007
CJS0610	.3741/.3750		.625		8,906	0.009
CJS0612	.3741/.3750		.750		10,688	0.011
CJS0808			.500		9,500	0.010
CJS0810	.4986/.5000	.5930/.5940	.625	.047	11,875	0.012
CJS0812			.750		14,250	0.014
CJS0816			1.000		19,000	0.019
CJS1008			.500		11,875	0.012
CJS1010	.6234/.6250	.7180/.7190	.625	.047	14,844	0.015
CJS1012			.750		17,813	0.018
CJS1016			1.000		23,750	0.024
CJS1208			.500		14,250	0.019
CJS1212	.7480/.7500	.8745/.8755	.750	.062	21,375	0.028
CJS1216			1.000		28,500	0.038
CJS1220			1.250		35,625	0.047
CJS1408			.500		16,625	0.022
CJS1414	.8730/.8750	.9995/1.0005	.875	.062	29,094	0.038
CJS1416			1.000		33,250	0.044
CJS1420			1.250		41,563	0.055
CJS1608			.500		19,000	0.025
CJS1612			.750		28,500	0.037
CJS1616	.9980/1.0000	1.1245/1.1255	1.000	.062	38,000	0.050
CJS1620			1.250		47,500	0.062
CJS1624			1.500		57,000	0.074
CJS1812			.750		32,063	0.053
CJS1816	1.1230/1.1250	1.2805/1.2815	1.000	.078	42,750	0.070
CJS1818			1.125		48,094	0.079
CJS1824			1.500		64,125	0.105

Part number example: CJS1216 is a split seam steel Fiberglide® / journal bearing with a .750 in. bore, 1.000 in. long.

Special and larger sizes can be supplied upon special order.

Series CJS

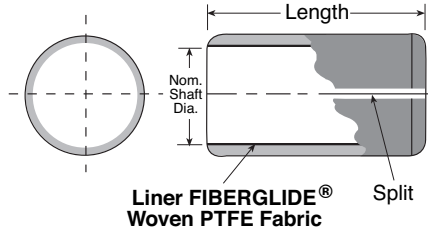

**Recommended housing bores are for steel housings. Contact engineering for recommended housing dimensions for alternate materials.*

STANDARD INCH SERIES

PART NUMBER	RECOMMENDED SHAFT DIAMETER MIN/MAX (in.)	RECOMMENDED* HOUSING BORE MIN/MAX (in.)	BEARING LENGTH +.000-.020 (in.)	WALL THICKNESS (in.) REF	MAX STATIC LOAD (lbf)	BEARING WEIGHT (lbs)
CJS2012	1.2475/1.2500	1.4055/1.4065	.750	.078	35,625	0.058
CJS2016			1.000		47,500	0.077
CJS2020			1.250		59,375	0.097
CJS2024			1.500		71,250	0.116
CJS2212	1.3730/1.3750	1.5305/1.5315	.750	.078	39,188	0.064
CJS2216			1.000		52,250	0.085
CJS2222			1.375		71,844	0.116
CJS2224			1.500		78,375	0.127
CJS2416	1.4975/1.5000	1.6555/1.6565	1.000	.078	57,000	0.092
CJS2424			1.500		85,500	0.138
CJS2428			1.750		99,750	0.161
CJS2816	1.7475/1.7500	1.9375/1.9385	1.000	.094	66,500	0.129
CJS2824			1.500		99,750	0.194
CJS2828			1.750		116,375	0.226
CJS2832			2.000		133,000	0.259
CJS3216	1.9970/2.0000	2.1875/2.1885	1.000	.094	76,000	0.147
CJS3224			1.500		114,000	0.220
CJS3232			2.000		152,000	0.294
CJS3618	2.2485/2.2500	2.4375/2.4385	1.125	.094	48,094	0.185
CJS3636			2.250		192,375	0.370
CJS4020	2.4970/2.5000	2.6875/2.6885	1.250	.094	118,750	0.228
CJS4040			2.500		237,500	0.455
CJS4422	2.7470/2.7500	2.9375/2.9385	1.375	.094	143,688	0.274
CJS4444			2.750		287,375	0.549
CJS4824	2.9970/3.0000	3.1875/3.1885	1.500	.094	171,000	0.326
CJS4848			3.000		342,000	0.651
CJS5628	3.4965/3.5000	3.6875/3.6885	1.750	.094	232,750	0.441
CJS5656			3.500		465,500	0.882
CJS6432	3.9965/4.0000	4.1875/4.1885	2.000	.094	304,000	0.575
CJS6464			4.000		608,000	1.149

Part number example: CJS1216 is a split seam steel Fiberglide® journal bearing with a .750 in. bore, 1.000 in. long. Special and larger sizes can be supplied upon special order.



Fiberglide® split seam steel journal bearings are designed to meet industry standards for self-lubricating bushings. Carbon steel is normally used as a backing material, with the external surfaces plated to resist corrosion. Other metals can be supplied upon special order. Typical applications include automotive vehicles, farm equipment, construction and material handling equipment. Fabroid® can also be supplied for special applications — consult Transport Dynamics engineering department. For bearing installation, see page 23.

STANDARD METRIC SERIES

PART NUMBER	RECOMMENDED SHAFT DIAMETER MIN/MAX (mm)	RECOMMENDED* HOUSING BORE MIN/MAX (mm)	BEARING LENGTH ± 0.25 (mm)	WALL THICKNESS (mm) REF	MAX STATIC LOAD (Newtons)	BEARING WEIGHT (grams)
CJM0808	7.9720/7.9870	10.0000/10.0150	8.00	1.0	16,768	1.443
CJM0810			10.00	1.0	20,960	1.803
CJM0812			12.00	1.0	25,152	2.164
CJM1008	9.9720/9.9870	12.0000/12.0180	8.00	1.0	20,960	1.764
CJM1010			10.00	1.0	26,200	2.205
CJM1012			12.00	1.0	31,440	2.646
CJM1020			20.00	1.0	52,400	4.410
CJM1208	11.9660/11.9840	14.0000/14.0180	8.00	1.0	25,152	2.086
CJM1210			10.00	1.0	31,440	2.607
CJM1212			12.00	1.0	37,728	3.128
CJM1220			20.00	1.0	62,880	5.214
CJM1415	13.9660/13.9840	16.0000/16.0180	15.00	1.0	55,020	4.513
CJM1420			20.00	1.0	73,360	6.018
CJM1512	14.9660/14.9840	17.0000/17.0180	12.00	1.0	47,160	3.852
CJM1515			15.00	1.0	58,950	4.815
CJM1525			25.00	1.0	98,250	8.024
CJM1612	15.9660/15.9840	18.0000/18.0180	12.00	1.0	50,304	4.093
CJM1615			15.00	1.0	62,880	5.116
CJM1620			20.00	1.0	83,840	6.821
CJM1625			25.00	1.0	104,800	8.527
CJM1815	17.9660/17.9840	20.0000/20.0210	15.00	1.0	70,740	5.719
CJM1820			20.00	1.0	94,320	7.625
CJM1825			25.00	1.0	117,900	9.532
CJM2015	19.9590/19.9800	23.0000/23.021	15.00	1.5	78,600	9.799
CJM2020			20.00	1.5	104,800	13.065
CJM2025			25.00	1.5	131,000	16.331
CJM2030			30.00	1.5	157,200	19.597

Part number example: CJM1012 is a split seam steel Fiberglide® / journal bearing with a 10mm bore, 12mm long. Larger diameters can be supplied.

Series CJM

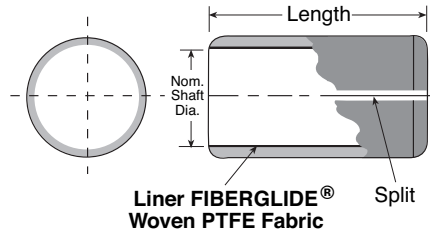

**Recommended housing bores are for steel housings. Contact engineering for recommended housing dimensions for alternate materials.*

STANDARD METRIC SERIES

PART NUMBER	RECOMMENDED SHAFT DIAMETER MIN/MAX (mm)	RECOMMENDED* HOUSING BORE MIN/MAX (mm)	BEARING LENGTH ± 0.25 (mm)	WALL THICKNESS (mm) REF	MAX STATIC LOAD (Newtons)	BEARING WEIGHT (grams)
CJM2215	21.9590/21.9800	25.0000/25.0210	15.00	1.5	86,460	10.711
CJM2220			20.00	1.5	115,280	14.282
CJM2225			25.00	1.5	144,100	17.852
CJM2230			30.00	1.5	172,920	21.422
CJM2415	23.9590/23.9800	27.0000/27.0210	15.00	1.5	94,320	11.624
CJM2420			20.00	1.5	125,760	15.498
CJM2425			25.00	1.5	157,200	19.373
CJM2430			30.00	1.5	188,640	23.248
CJM2515	24.9590/24.9800	28.0000/28.0210	15.00	1.5	98,250	12.080
CJM2520			20.00	1.5	131,000	16.107
CJM2525			25.00	1.5	163,750	20.134
CJM2530			30.00	1.5	196,500	24.160
CJM2550			50.00	1.5	327,500	40.267
CJM3010	29.9590/29.9820	34.0000/34.0250	10.00	2.0	78,600	13.000
CJM3015			15.00	2.0	117,900	19.500
CJM3020			20.00	2.0	157,200	26.000
CJM3025			25.00	2.0	196,500	32.501
CJM3030			30.00	2.0	235,800	39.001
CJM3520	34.9500/34.9750	39.0000/39.0250	20.00	2.0	183,400	30.067
CJM3530			30.00	2.0	275,100	45.100
CJM3535			35.00	2.0	320,950	52.617
CJM3540			40.00	2.0	366,800	60.134
CJM3550	50.00	2.0	458,500	75.167		
CJM4020	39.9500/39.9750	44.0000/44.0250	20.00	2.0	209,600	34.133
CJM4030			30.00	2.0	314,400	51.200
CJM4040			40.00	2.0	419,200	68.267
CJM4050			50.00	2.0	524,000	85.334
CJM4520	44.0000/44.0250	50.0000/50.0250	20.00	2.0	235,800	48.307
CJM4530			30.00	2.0	353,700	72.461
CJM4540			40.00	2.0	471,600	96.614
CJM4545			45.00	2.0	530,550	108.691
CJM4550			50.00	2.0	589,500	120.768

Part number example: CJM1012 is a split seam steel *Fiberglide®* / journal bearing with a 10mm bore, 12mm long. Larger diameters can be supplied.



The constant wall thickness of .062 of the CJT SERIES makes them dimensionally interchangeable with other types of steel bearings commonly used. They provide all the advantages of Fiberglide® at minimum cost. Carbon steel is normally used as a backing material, with the external surfaces plated to resist corrosion. Other metals can be supplied upon special order. Typical applications include automotive vehicles, farm equipment, construction and material handling equipment.

A Fabroid® Liner can also be supplied for special applications — consult Transport Dynamics engineering department. For bearing installation, see page 23.

STANDARD THIN WALL INCH SERIES

PART NUMBER	RECOMMENDED SHAFT DIAMETER MIN/MAX (in.)	RECOMMENDED* HOUSING BORE MIN/MAX (in.)	BEARING LENGTH (in.) +.000 -.020	WALL THICKNESS (in.) REF	MAX STATIC LOAD (lbf)	BEARING WEIGHT (lbs)
CJT0808	.4936/.5000	.6240/.6250	.500	.062	7,500	.011
CJT0810			.625	.062	9,375	.014
CJT0812			.750	.062	11,250	.017
CJT0816			1.000	.062	15,000	.023
CJT1008	.6234/.6250	.7490/.7500	.500	.062	9,375	.014
CJT1010			.625	.062	11,719	.017
CJT1012			.750	.062	14,062	.021
CJT1016			1.000	.062	18,750	.028
FOR SIZES 12XX THROUGH 16XX USE CJS SERIES (PAGE 4)						
CJT1812	1.1230/1.1250	1.2495/1.2505	.750	.062	25,312	.036
CJT1816			1.000	.062	33,750	.048
CJT1818			1.125	.062	37,969	.054
CJT1824			1.500	.062	50,625	.072
CJT2012	1.2475/1.2500	1.3745/1.3755	.750	.062	28,125	.040
CJT2016			1.000	.062	37,500	.053
CJT2020			1.250	.062	46,875	.066
CJT2024			1.500	.062	56,250	.079
CJT2212	1.3725/1.3750	1.4995/1.5005	.750	.062	30,937	.043
CJT2216			1.000	.062	41,250	.058
CJT2222			1.375	.062	56,719	.080
CJT2224			1.500	.062	61,875	.087
CJT2416	1.4975/1.5000	1.6245/1.6255	1.000	.062	45,000	.063
CJT2424			1.500	.062	67,500	.094
CJT2428			1.750	.062	78,750	.110

Part number example: CJT2024 is a split seam Fiberglide® / journal bearing with 1.25 in. bore, 1.50 in. long. Larger diameters can be supplied.

Series CJT

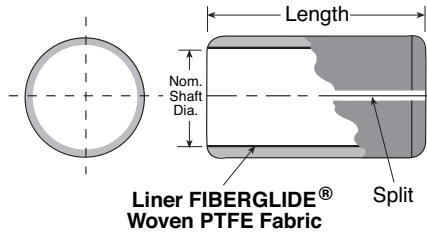

*Recommended housing bores are for steel housings. Contact engineering for recommended housing dimensions for alternate materials.

STANDARD THIN WALL INCH SERIES

PART NUMBER	RECOMMENDED SHAFT DIAMETER MIN/MAX (in.)	RECOMMENDED* HOUSING BORE MIN/MAX (in.)	BEARING LENGTH (in.) +.000 -.020	WALL THICKNESS (in.) REF	MAX STATIC LOAD (lbf)	BEARING WEIGHT (lbs)
CJT2816	1.7475/1.7500	1.8745/1.8755	1.000	.062	52,500	.073
CJT2824			1.500	.062	78,750	.109
CJT2828			1.750	.062	91,875	.128
CJT2832			2.000	.062	105,000	.146
CJT3216	1.9970/2.0000	2.1245/2.1255	1.000	.062	60,000	.083
CJT3224			1.500	.062	90,000	.124
CJT3232			2.000	.062	120,000	.166
CJT3618	2.2470/2.2500	2.3745/2.3755	1.125	.062	37,969	.789
CJT3636			2.250	.062	151,875	.209
CJT4020	2.4970/2.5000	2.6245/2.6255	1.250	.062	93,750	.129
CJT4040			2.500	.062	187,500	.258
CJT4422	2.7475/2.7500	2.8745/2.8755	1.375	.062	113,438	.156
CJT4444			2.750	.062	226,875	.311
CJT4824	2.9975/3.0000	3.1245/3.1255	1.500	.062	135,000	.185
CJT4848			3.000	.062	270,000	.370
CJT5628	3.4965/3.5000	3.6245/3.6255	1.750	.062	183,750	.251
CJT5656			3.500	.062	367,500	.501
CJT6030	3.7465/3.7500	3.8745/3.8755	1.875	.062	210,938	.287
CJT6060			3.750	.062	421,875	.575
CJT6432	3.9965/4.0000	4.1245/4.1255	2.000	.062	240,000	.327
CJT6464			4.000	.062	480,000	.654

Part number example: **CJT2024** is a split seam **Fiberglide®** / journal bearing with 1.25 in. bore, 1.50 in. long. Larger diameters can be supplied.



The constant wall thickness of 1/8 in. (.125) for the CJH series makes them dimensionally interchangeable with many bronze and filament wound bushings. Carbon steel is used as a backing material, with the external surfaces plated to resist corrosion. Typical applications include farm equipment, construction and material handling equipment. **Fabroid®** can also be supplied for special applications. Consult Transport Dynamics engineering department. For bearing installation, see page 23.

Series CJH

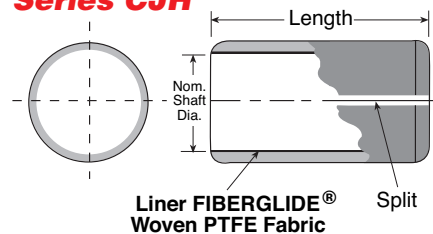

Replaces Bronze Bushings

**Recommended housing bores are for steel housings. Contact engineering for recommended housing dimensions for alternate materials.*

STANDARD HEAVY WALL INCH SERIES

PART NUMBER	RECOMMENDED SHAFT DIAMETER MIN/MAX (in.)	RECOMMENDED* HOUSING BORE MIN/MAX (in.)	BEARING LENGTH (in.) +.000 -.020	WALL THICKNESS (in.) REF	MAX STATIC LOAD (lbf)	BEARING WEIGHT (lbs)
CJH1204			.250		7,125	0.020
CJH1208	.7480/1.7500	.9995/1.0005	.500	.125	14,250	0.041
CJH1212			.750		21,375	0.061
CJH1608			.500		19,000	0.052
CJH1612	.9980/1.0000	1.2495/1.2505	.750	.125	28,500	0.079
CJH1616			1.000		38,000	0.105
CJH2016			1.000		47,500	0.128
CJH2020	1.2480/1.2500	1.4995/1.5005	1.250	.125	59,375	0.160
CJH2024			1.500		71,250	0.192
CJH2216			1.000		52,250	0.140
CJH2220	1.3730/1.3750	1.6245/1.6255	1.250	.125	65,313	0.175
CJH2224			1.500		78,375	0.209
CJH2420			1.250		71,250	0.189
CJH2424	1.4975/1.5000	1.7495/1.7505	1.500	.125	85,500	0.227
CJH2432			2.000		114,000	0.302
CJH2820			1.250		83,125	0.218
CJH2824	1.7475/1.7500	1.9995/2.0005	1.500	.125	99,750	0.262
CJH2832			2.000		133,000	0.349
CJH3224			1.500		114,000	0.297
CJH3232	1.9970/2.0000	2.2495/2.2505	2.000	.125	152,000	0.396
CJH3248			3.000		228,000	0.593
CJH3624			1.500		128,250	0.332
CJH3632	2.2470/2.2500	2.4995/2.5005	2.000	.125	171,000	0.442
CJH3648			3.000		256,500	0.663
CJH4032			2.000		190,000	0.489
CJH4040	2.4970/2.5000	2.7495/2.7505	2.500	.125	237,500	0.611
CJH4048			3.000		285,000	0.733
CJH4432			2.000		209,000	0.535
CJH4440	2.7470/2.7500	2.9995/3.0005	2.500	.125	261,250	0.669
CJH4448			3.000		313,500	0.803
CJH4832			2.000		228,000	0.582
CJH4840	2.9970/3.0000	3.2495/3.2505	2.500	.125	285,000	0.727
CJH4848			3.000		342,000	0.873
CJH5232			2.000		247,000	0.675
CJH5240	3.2465/3.2500	3.4995/3.5005	2.500	.125	308,750	0.843
CJH5248			3.000		370,500	1.012
CJH5632			2.000		266,000	0.675
CJH5664	3.4965/3.5000	3.7495/3.7505	4.000	.125	532,000	1.350
CJH6032			2.000		304,000	0.721
CJH6064	3.7465/3.7500	3.9995/4.0005	4.000	.125	608,000	1.443
CJH6432			2.000		304,000	0.768
CJH6464	3.9965/4.0000	4.2495/4.2505	4.000	.125	608,000	1.536

Part number example: CJH1212 is a coiled steel journal bearing with .75 in. bore, .75 in. long.

Special and larger sizes can be supplied upon special order.



The **Fiberglide®** Liner Type bearing provides high load capacity and low friction in the form of a thin-walled sleeve for use in butterfly valves, trunnion bearings, ball and plug valve stem bushings, hydraulic and pneumatic cylinder bushings, food handling machinery, and door hinge bushings, among others. Because these bearings are completely non-metallic-fabricated of woven PTFE fibers on the bore supported by a laminated backing-there is no possibility of corrosion. Maximum compressive strength is 10,000 psi, with operating temperature range of -250°F to 200°F. Maximum speeds are typically 20 surface FPM.

Series LJS

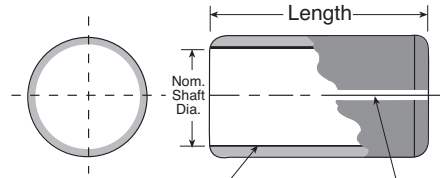

Liner FIBERGLIDE® Woven PTFE Fabric

**Recommended housing bores are for steel housings. Contact engineering for recommended housing dimensions for alternate materials.*

NON-METALLIC BEARING INCH SERIES

PART NUMBER	RECOMMENDED SHAFT DIAMETER (in.)	RECOMMENDED* HOUSING BORE MIN/MAX (in.)	BEARING LENGTH (in.) +.000 -.025	WALL THICKNESS (in.) REF	MAX STATIC LOAD (lbf)
LJS1616			1.000		10,000
LJS1624	1.000	1.071/1.072	1.500	.035	15,000
LJS1632			2.000		20,000
LJS1818			1.125		12,656
LJS1828	1.125	1.196/1.197	1.500	.035	16,875
LJS1836			2.250		25,313
LJS2020			1.250		15,625
LJS2030	1.250	1.321/1.322	1.875	.035	23,438
LJS2040			2.500		31,250
LJS2222			1.375		18,906
LJS2232	1.375	1.446/1.447	2.000	.035	27,500
LJS2244			2.750		37,813
LJS2424			1.500		22,500
LJS2436	1.500	1.571/1.572	2.250	.035	33,750
LJS2448			3.000		45,000
LJS2828			1.750		30,625
LJS2842	1.750	1.821/1.822	2.625	.035	45,938
LJS2856			3.500		61,250
LJS3232			2.000		40,000
LJS3248	2.000	2.126/2.127	3.000	.062	60,000
LJS3636			2.250		50,625
LJS3654	2.250	2.376/2.377	3.375	.062	75,938
LJS4040			2.500		62,500
LJS4060	2.500	2.626/2.627	3.750	.062	93,750
LJS4444			2.750		75,625
LJS4466	2.750	2.876/2.877	4.125	.062	113,438
LJS4848			3.000		90,000
LJS4872	3.000	3.126/3.127	4.500	.062	135,000
LJS5656			3.500		122,500
LJS5684	3.500	3.626/3.627	5.250	.062	183,750
LJS6464			4.000		160,000
LJS6496	4.000	4.126/4.127	6.000	.062	240,000
LJS7272			4.500		202,500
LJS8080	4.500	4.626/4.627	5.000	.062	250,000
LJS8888			5.500		302,500
LJS9696	5.500	5.626/5.627	6.000	.062	360,000

Part number example: LJS1624 is a liner with 1.00 in. bore, 1.50 in. long.

Larger diameters can be supplied.

These bearings slip into the housing bore and may require positive retention. For bearing installation other than that shown on page 23, consult Transport Dynamics engineering department.



Fibriloid® SJS Series Solid Journal Bearings were developed for high impact demanding applications in mining, large construction equipment, cranes, and heavily loaded military vehicles. The standard line is supplied with **Fibriloid®** self-lubricated bearing liners. Other materials and liners are available upon consultation with the Transport Dynamics engineering department. These components can also be supplied with seals for demanding applications in contaminated fluid environments.

Series SJS

**Recommended housing bores are for steel housings. Contact engineering for recommended housing dimensions for alternate materials.*

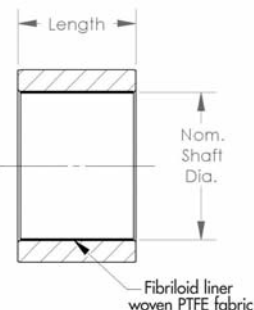

SOLID MACHINED BEARING

PART NUMBER	RECOMMENDED SHAFT DIAMETER MIN/MAX (in.)	RECOMMENDED* HOUSING BORE MIN/MAX (in.)	BEARING LENGTH (in.) +.000 -.010	WALL THICKNESS (in.) REF	MAX STATIC LOAD (lbf)
SJS1616			1.000	.250	38,000
SJS1620			1.250	.250	47,500
SJS1624	.9980/1.0000	1.4984/1.5000	1.500	.250	57,000
SJS1632			2.000	.250	76,000
SJS2016			1.000	.250	47,500
SJS2020	1.2475/1.2500	1.7484/1.7500	1.250	.250	59,375
SJS2024			1.500	.250	71,250
SJS2032			2.000	.250	95,000
SJS2416			1.000	.250	57,000
SJS2420	1.4975/1.5000	1.9982/2.0000	1.250	.250	71,250
SJS2424			1.500	.250	85,500
SJS2432			2.000	.250	114,000
SJS2816			1.000	.250	66,500
SJS2824	1.7475/1.7500	2.2482/2.2500	1.500	.250	99,750
SJS2832			2.000	.250	133,000
SJS2840			2.500	.250	166,250
SJS3216			1.000	.250	76,000
SJS3220	1.9970/2.0000	2.4982/2.5000	1.250	.250	95,000
SJS3224			1.500	.250	114,000
SJS3232			2.000	.250	152,000
SJS3616			1.000	.250	85,500
SJS3624	2.2470/2.2500	2.7482/2.7500	1.500	.250	128,250
SJS3632			2.000	.250	171,000
SJS3648			3.000	.250	256,500
SJS4024			1.500	.250	142,500
SJS4032	2.4970/2.5000	2.9982/3.0000	2.000	.250	190,000
SJS4040			2.500	.250	237,500
SJS4048			3.000	.250	285,000
SJS4424			1.500	.250	156,750
SJS4432	2.7470/2.7500	3.2478/3.2500	2.000	.250	209,000
SJS4448			3.000	.250	313,500
SJS4824			1.500	.250	171,000
SJS4832	2.9970/3.0000	3.4978/3.5000	2.000	.250	228,000
SJS4848			3.000	.250	342,000
SJS5632			2.000	.250	266,000
SJS5648	3.4970/3.5000	3.9978/4.0000	3.000	.250	399,000
SJS5656			3.500	.250	465,500
SJS6432			2.000	.250	304,000
SJS6448	3.9970/4.0000	4.4975/4.5000	3.000	.250	456,000
SJS6464			4.000	.250	608,000
SJS7232			2.000	.250	342,000
SJS7248	4.4970/4.5000	4.9975/5.0000	3.000	.250	513,000
SJS7264			4.000	.250	684,000
SJS8040			2.500	.250	475,000
SJS8048	4.9970/5.0000	5.4975/5.5000	3.000	.250	570,000
SJS8064			4.000	.250	760,000

Part number example: **SJS2024** is a steel journal bearing with 1.25 in. bore, 1.50 in. long Larger diameters can be supplied.

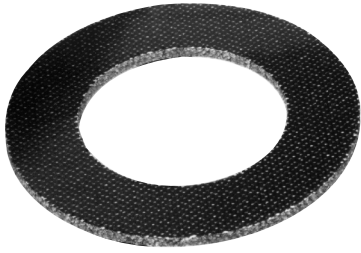

Phenolic-backed **Fiberglide®** thrust bearings provide high load capacity and low friction for use where the elimination of lubrication is desirable. Typical applications include industrial valves and valve actuators, vehicle kingpin assemblies and marine drives.

Non-metallic and hence non-corrosive, these **Fiberglide®** thrust bearings are lightweight and are fabricated of **Fiberglide®** fibers backed by a laminated phenolic resin system. Double sided construction extends bearing life. It is important that mating surfaces be smooth and free from sharp edges.

Maximum compressive strength is 10,000 psi, with operating temperature range of -250°F to 200°F. For bearing installation, see page 23.

PHENOLIC-BACKED THRUST WASHERS

PART NUMBER	MAXIMUM SHAFT DIAMETER (in.)	I.D. +.020 - .000 (in.)	O.D. +.000 - .020 (in.)	T ±.002 (in.)	MAX STATIC LOAD (lbf)
LTD0408	0.250	0.280	0.500	0.033	1,348
LTD0510	0.312	0.344	0.625	0.033	2,138
LTD0612	0.375	0.406	0.750	0.033	3,123
LTD0714	0.437	0.468	0.875	0.033	4,293
LTD0816	0.500	0.531	1.000	0.033	5,639
LTD0918	0.562	0.593	1.125	0.063	7,178
LTD1020	0.625	0.656	1.250	0.063	8,892
LTD1122	0.687	0.718	1.375	0.063	10,800
LTD1224	0.750	0.781	1.500	0.063	12,880
LTD1326	0.812	0.843	1.625	0.063	15,158
LTD1428	0.875	0.906	1.750	0.063	17,605
LTD1530	0.937	0.968	1.875	0.063	20,252
LTD1632	1.000	1.031	2.000	0.063	23,067
LTD1834	1.125	1.156	2.125	0.063	24,969
LTD2036	1.250	1.281	2.250	0.063	26,872
LTD2240	1.375	1.406	2.500	0.063	33,560
LTD2442	1.500	1.531	2.625	0.094	35,708
LTD2644	1.625	1.656	2.750	0.094	37,856
LTD2846	1.750	1.781	2.875	0.094	40,004
LTD3048	1.875	1.906	3.000	0.094	42,152
LTD3252	2.000	2.062	3.250	0.094	49,562
LTD3654	2.250	2.312	3.375	0.094	47,478
LTD4060	2.500	2.562	3.750	0.094	58,893
LTD4466	2.750	2.812	4.125	0.094	71,534
LTD4872	3.000	3.062	4.500	0.094	85,403
LTD5278	3.250	3.312	4.875	0.094	100,499

Part number example: LTD1834 is a double-sided thrust bearing with 1.156 in. bore 2.125 in. O.D.

Different thicknesses and larger diameters can be provided and smaller bore diameters are available on request

Series LTD

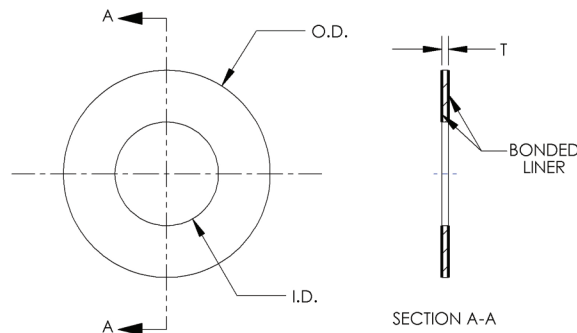



Fiberglide® FTS series thrust bearings offer an economical approach to obtaining self-lubrication where high loads are encountered. They are comprised of zinc-plated mild steel with Fiberglide® laminated to one face. These bearings are recommended for use as an alternate to LTD washers in applications where metal backing is preferred.

Maximum compressive strength is 38,000 psi, with operating temperature range of -320°F to 300°F. Friction coefficients as low as 0.03 with no added lubricants are obtainable.

Fabroid® Liners can also be supplied. For special applications, consult Transport Dynamics engineering department. These thrust bearings can also be supplied with special metals and with liners on both sides (FTD) series.

SINGLE-SIDED METAL BACKED, INCH

PART NUMBER	MAXIMUM SHAFT DIAMETER (in.)	I.D. +.020 - .000 (in.)	O.D. +.000 - .020 (in.)	T ±.002 (in.)	MAX STATIC LOAD (lbf)
FTS0408	.250	.280	.500	.058	5,121
FTS0510	.312	.344	.625	.058	8,126
FTS0612	.375	.406	.750	.058	11,868
FTS0714	.437	.468	.875	.058	16,313
FTS0816	.500	.531	1.000	.058	21,429
FTS0918	.562	.593	1.125	.058	27,277
FTS1020	.625	.656	1.250	.058	33,789
FTS1122	.687	.718	1.375	.058	41,039
FTS1224	.750	.781	1.500	.058	48,946
FTS1326	.812	.843	1.625	.058	57,599
FTS1428	.875	.906	1.750	.058	66,901
FTS1530	.937	.968	1.875	.058	76,956
FTS1632	1.000	1.031	2.000	.058	87,654
FTS1834	1.125	1.156	2.125	.058	94,883
FTS2036	1.250	1.281	2.250	.058	102,113
FTS2240	1.375	1.406	2.500	.058	127,529
FTS2442	1.500	1.531	2.625	.058	135,692
FTS2644	1.625	1.656	2.750	.058	143,854
FTS2846	1.750	1.781	2.875	.058	152,017
FTS3048	1.875	1.906	3.000	.058	160,179
FTS3252	2.000	2.062	3.250	.058	188,337
FTS3654	2.250	2.312	3.375	.058	180,417
FTS4060	2.500	2.562	3.750	.058	223,792
FTS4466	2.750	2.812	4.125	.058	271,830
FTS4872	3.000	3.062	4.500	.058	324,531
FTS5278	3.250	3.312	4.875	.058	381,895

Part number example: FTS1834 is a metal-backed thrust bearing, with 1.156 in. bore, 2.125 in. O.D.
Different thicknesses and larger diameters can be supplied.

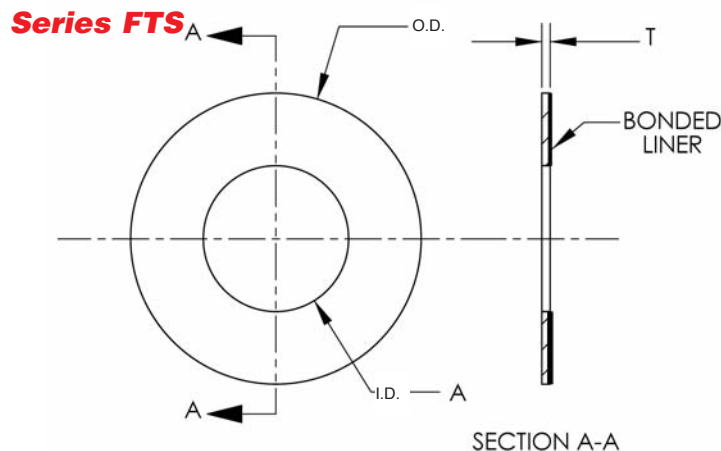



Fiberglide® FTM series thrust bearings offer an economical approach to obtaining self-lubrication where high loads are encountered. They are comprised of zinc-plated mild steel with Fiberglide® laminated to one face. These bearings are recommended for use as an alternate to LTD washers in applications where metal backing is preferred.

Maximum compressive strength is 38,000 psi, with operating temperature range of -320°F to 300°F. Friction coefficients as low as 0.03 with no added lubricants are obtainable.

Fabroid® Liners can also be supplied for special applications, consult Transport Dynamics engineering department. These thrust bearings can also be supplied with special metals and with liners on both sides (FTD) Series.

SINGLE-SIDED METAL BACKED, METRIC

PART NUMBER	MAXIMUM SHAFT DIAMETER (mm)	I.D. +.508 - .000 (mm)	O.D. +.000 - .508 (mm)	T ±.05 (mm)	MAX STATIC LOAD (Newtons)
FTM0820	8	10	20	1.50	61,730
FTM1024	10	12	24	1.50	88,892
FTM1226	12	14	26	1.50	98,769
FTM1632	16	18	32	1.50	144,038
FTM1836	18	20	36	1.50	184,368
FTM2038	20	22	38	1.50	197,538
FTM2240	22	24	40	1.50	210,707
FTM2444	24	26	44	1.50	259,268
FTM2548	25	28	48	1.50	312,768
FTM2850	28	30	50	1.50	329,229
FTM3054	30	32	54	1.50	389,314
FTM3562	35	38	62	1.50	493,844
FTM4066	40	42	66	1.50	533,351
FTM4574	45	48	74	2.00	652,697
FTM5078	50	52	78	2.00	695,497
FTM6090	60	62	90	2.00	875,750

Part number example: *FTM1632 is a metal backed metric thrust bearing, with 18 mm I.D. and 32 mm O.D.*
Different thicknesses and larger diameters can be supplied.

Series FTM

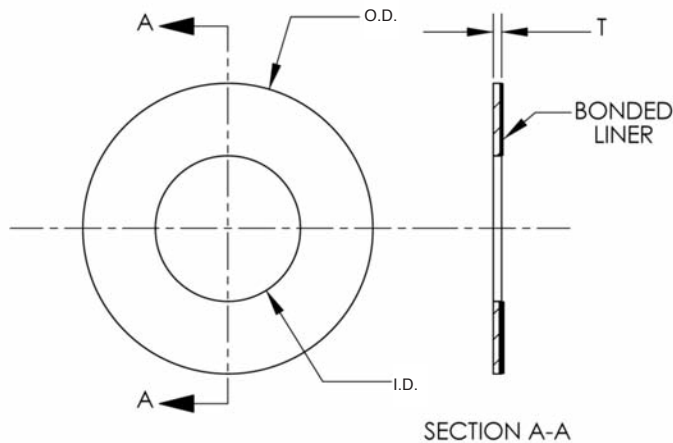



Fiberglide® Slim Pack thrust bearings are unique in the industry. They need no lubrication, can tolerate extremely high loads and require very little space. (Nominal thickness is only 1/8 in.) The advanced, patented design includes a self-contained dust seal and utilizes materials which resist corrosion. It provides its own smooth internal wear surface which is ideal where cast iron or other rough mating surfaces are present. Slim Pack thrust bearings are particularly suited for such applications as vehicle kingpin assemblies, and frame hinges. For bearing installation, see page 23.

Series FTP

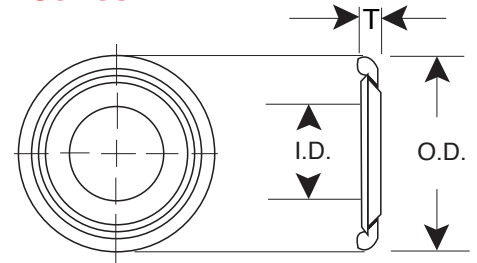

SLIM PACK THRUST BEARING ASSEMBLY

PART NUMBER	I.D. +.005 +.025 (in.)	O.D. +.010 -.020 (in.)	T ±.010 (in.)	AREA in. ²	MAX STATIC LOAD (lbf)
FTP1628	1.000	1.750	.130	1.25	47,500
FTP2032	1.250	2.000	.130	1.48	56,240
FTP2436	1.500	2.250	.130	1.72	65,360
FTP2638	1.625	2.375	.130	1.84	69,920
FTP2840	1.750	2.500	.130	1.96	74,480
FTP3244	2.000	2.750	.130	2.19	83,220
FTP3648	2.250	3.000	.130	2.43	92,340
FTP4052	2.500	3.250	.130	2.66	101,080
FTP4072	2.500	4.500	.130	10.03	381,140
FTP4874	3.000	4.625	.130	8.72	331,360

Part number example: *FTP3648 is a thrust pack with a 2.25 inch I.D. and 3 inch O.D.*

**T is measured with pack loaded*

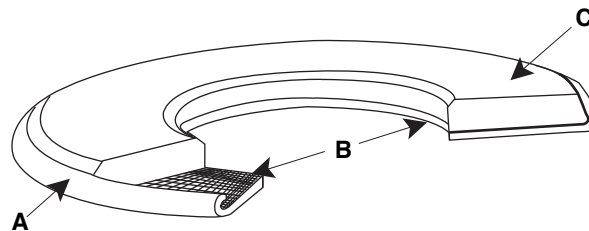

Diagram shows:

- A. Outer metal shell
 - B. Fiberglide®/Fabroid® self-lubricating liner
 - C. Inner metal ring hard plate wear surface.
- Ring rotates against Fiberglide®/Fabroid® liner which is bonded to outer shell.



The outer ring is swaged over the ball to provide maximum race to ball conformity. The inner ring, ball is a fully hardened ball which provides strength when clamped in the application. Aerospace-grade materials are used in our swaged bearings. The race is CRES 17-4PH, AMS5643, HRC 28 min, and the balls are CRES 440C, AMS5630, HRC 55min. The liner is Fibriloid® qualified to AS81820. Swaged bearings are constructed and equipped with a self-lubricating liner system to reduce friction. These bearings provide misalignment and high load carrying capacity. Features include high temperature-low wear -65°F to +325° (-53.9°C +162.8°C)

SELF-LUBRICATED SPHERICAL BEARINGS, NARROW

Dimensions — Tolerances								Load Ratings				
MS14104 Chamfered Part Numbers	B +.0000, -.0005 in.	D +.0000, -.0005 in.	H ±.005 in.	W +.000, -.002 in.	A Min. in.	C ⁽¹⁾ +.010, -.000 in.	X° Ref.	Oscillating Radial Load Rating ⁽¹⁾ lbf.	Radial Limit Load Rating* lbf.	Axial Limit Load Rating* lbf.	No Load Rotational Breakaway Torque in.-lbs.	Weight Max. Ref. lbs.
0382303	.1900	.6250	.218	.281	.293	.010	10	1,500	3,975	150	.25-5	.02
0382304	.2500	.6562	.250	.343	.364	.010	10	3,320	6,040	430	.25-5	.02
0382305	.3125	.7500	.281	.375	.419	.010	10	5,460	8,750	700	.25-8	.03
0382306	.3750	.8125	.312	.406	.475	.020	9	6,600	10,540	1100	.25-8	.04
0382307	.4375	.9062	.343	.437	.530	.020	8	8,050	13,200	1400	.25-8	.05
0382308	.5000	1.0000	.390	.500	.600	.020	8	10,400	17,900	2100	.25-8	.07
0382309	.5625	1.0937	.437	.562	.670	.020	8	13,000	23,200	3680	.25-8	.09
0382310	.6250	1.1875	.500	.625	.739	.020	8	16,450	30,500	4720	.25-8	.12
0382312	.7500	1.4375	.593	.750	.920	.030	8	23,600	46,400	6750	.25-8	.21
0382314	.8750	1.5625	.703	.875	.980	.030	8	32,050	62,200	9350	.25-12	.27
0382316	1.0000	1.7500	.797	1.000	1.118	.030	9	38,000	82,200	12160	.25-12	.39

⁽¹⁾Load rating based on AS81820. -3 and -4 sizes are limited by pin bending.

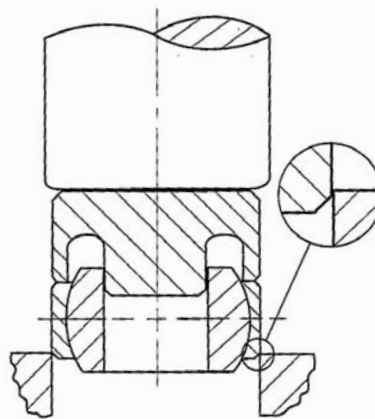
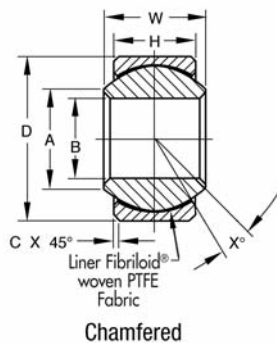

Spherical bearing assembly tool



The outer ring is swaged over the ball to provide maximum race to ball conformity. The inner ring, ball is a fully hardened ball which provides strength when clamped in the application. Aerospace-grade materials are used in our swaged bearings. The race is CRES 17-4PH, AMS5643, HRC 28 min, and the balls are CRES 440C, AMS5630, HRC 55min. The liner is Fibriloid® qualified to AS81820. Swaged bearings are constructed and equipped with a self-lubricating liner system to reduce friction. These bearings provide misalignment and high load carrying capacity. Features include high temperature-low wear -65°F to +325° (-53.9°C +162.8°C)

SELF-LUBRICATED SPHERICAL BEARINGS, WIDE

Dimensions — Tolerances								Load Ratings				
MS14102 Chamfered Part Numbers	B +.0000, -.0005 in.	D +.0000, -.0005 in.	H ±.005 in.	W +.000, -.002 in.	A Min. in.	C ⁽¹⁾ +.010, -.000 in.	X° Ref.	Oscillating Radial Load Rating* lbf.	Radial Limit Load Rating* lbf.	Axial Limit Load Rating* lbf.	No Load Rotational Breakaway Torque (Standard) in.-lbs.	Weight Max. Ref. lbs.
0382403	.1900	.6250	.327	.437	.300	.010	15	4,900	2,500	1,770	.25-5	.03
0382404	.2500	.6250	.327	.437	.300	.010	15	4,900	5,500	1,770	.25-5	.03
0382405	.3125	.6875	.317	.437	.360	.010	14	6,050	9,400	1,640	.25-8	.04
0382406	.3750	.8125	.406	.500	.466	.020	8	8,310	13,700	2,630	.25-8	.06
0382407	.4375	.9375	.442	.562	.537	.020	10	11,750	20,700	3,650	.25-8	.08
0382408	.5000	1.0000	.505	.625	.607	.020	9	14,950	21,400	4,970	.25-8	.10
0382409	.5625	1.1250	.536	.687	.721	.020	10	18,100	26,600	5,370	.25-8	.14
0382410	.6250	1.1875	.567	.750	.747	.020	12	20,250	29,000	6,130	.25-8	.16
0382412	.7500	1.3750	.630	.875	.845	.030	13	26,200	37,000	7,730	.25-8	.24
0382414	.8750	1.6250	.755	.875	.995	.030	6	33,600	65,200	10,800	.25-12	.35
0382416	1.0000	2.1250	1.005	1.375	1.269	.030	12	56,250	104,000	19,300	.25-12	.97

*Load rating based on AS81820. -3 and -4 sizes are limited by pin bending.

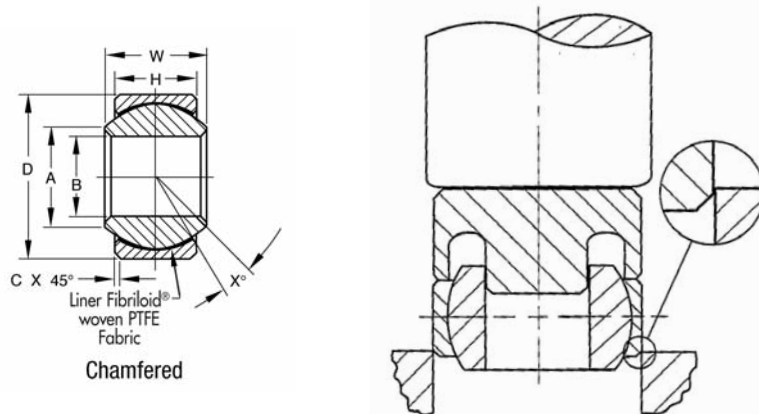

Spherical bearing assembly tool

MAINTENANCE-FREE SELF LUBRICATING BEARINGS

Many factors affect the overall performance of Fiberglide®/Fabroid® bearings. Those of primary concern include applied load, surface velocity, operating mode, surface temperature, mating surface finish and running clearance.

All performance values referred to in this section are based on dry operation. When running in a fluid atmosphere, Fiberglide®/Fabroid® bearings may have limitations. Where application requirements exceed those shown, consult Transport Dynamics engineering department for specific recommendations.

Fiberglide®/Fabroid® lined bearings are designed to be used under oscillating motion, interrupted start-stop, impact loading or axial motion. They are recommended where high loads, are combined with low surface speeds.

DESIGN CALCULATIONS

(journals-oscillating motion) CPM=cycles per minute

Proj. Area (sq.in.) = Shaft Dia. Max (or Nom. I.D.) x length

P Pressure (psi) = Load (Lbf) ÷ by Proj. Area

V. Velocity (FPM) = $\frac{\text{Shaft Dia. Max} \times \pi}{12} \times \frac{4 \times \text{osc. Angle} \times \text{CPM}}{360}$

BEARING WEAR

Bearing wear is affected by many factors. For the most part, tests conducted by Transport Dynamics subject journal bearings to 20,000 psi loads with the bearing fixed and the shaft oscillating. The values shown in the charts on page 21 are representative of the normal wear rate range that can be expected when amplitude is ±45°, frequency is 10 CPM, and shaft finish is 16 RMS under room temperature conditions.

It will be noted that a wear-in period takes place during the first few thousand cycles. During this period some PTFE is transferred to the mating surface. In addition, the fibers are generally reoriented, the high points of the weave are flattened and adjacent fibers tend to blend together. After the break-in period, the bearing surface will become smooth and shiny.

Because of the many variables which influence wear, it is extremely difficult to project bearing life for all types of applications. For this reason, the Transport Dynamics engineering department should be consulted when questions of this nature arise. Wear life calculations are based on rubbing distance of travel.

BEARING LOAD LIMITS (Standard Fiberglide®/Fabroid®)

Static Pressure Limit (Constant pressure*)

10,000 (70Mpa) psi with phenolic backing
38,000 (262 Mpa) psi with steel backing

Dynamic pressure limits while oscillating

20,000 psi (140 Mpa) suggested maximum with steel backing.

*Where repeated impact loading is applied, these values should be reduced to meet fatigue life requirements.

VELOCITY LIMIT

Under dry running conditions, the maximum allowable surface velocity will depend on the applied load and other operating parameters. In general, surface speed should be kept below 35 FPM (Feet Per Minute) (11 m/min) at 10,000 psi (70 Mpa) load or 600 FPM (183 m/min) at 100 psi (.7 Mpa) load.

PV FACTOR

For plain, dry-running bearings, it is often helpful to reference a pressure-velocity (PV) factor as a guide in determining bearing capability. It should be understood that this factor is actually a variable which reflects the point where surface temperatures are at a maximum, but are still stable. The maximum PV established for Fiberglide®/Fabroid® is:

PV continuous-50,000
PV intermittent-150,000

TEMPERATURE LIMIT

Normal operating temperatures should be kept below 300°F (149° C) for standard Fiberglide®/Fabroid® bearings. An increase in wear rates may be experienced at temperatures above 350°F (177° C). Note that at elevated operating temperatures, the PV limit will be decreased in order to prevent the surface temperature from exceeding 300°F (149° C), (environmental temperature plus friction heat generated). When temperatures exceed 300°F (149° C) or fall below -200°F (-129° C), consult Transport Dynamics engineering department for specific recommendations.

COEFFICIENT OF THERMAL EXPANSION

When bonded to a metal backing, Fiberglide®/Fabroid®'s coefficient of expansion can normally be regarded as identical to that of the backing, with steel backing 8.4×10^{-6} in/in/°F.

MATING SURFACES

Fiberglide®/Fabroid®, being non-metallic, will operate against most metals, but better performance is obtained with the hardest available mating surfaces. Hardened steel, hard anodized aluminum, hard chrome or nickel plate are recommended. A surface hardness of 45-50 R_C is desirable, but satisfactory performance can also be obtained with softer materials. Generally, a surface finish on the mating components of 16-32 μ inch (0.4-0.8μm) should be provided. Shaft materials or surface treatments should be selected that will effectively resist corrosion.

To determine the approximate reduction in life for different values of shaft finish and hardness, see below.

SURFACE FINISH μ in. / μ m	LIFE FACTOR	HARDNESS Rockwell Reading	LIFE FACTOR
8-16/0.2-0.4	1.00	R _C 50	1.00
32/0.8	0.55	R _C 40	0.60
63/1.6	0.20	R _C 30	0.40

COEFFICIENT OF FRICTION

Coefficient of friction depends upon type of movement, finish of mating surface, ambient temperature, bearing pressure, velocity and other variables. Figs. 1, 2, and 3 were obtained from flat specimens and may be used as a guide. Note in Fig. 1 that the coefficient drops off as bearing load increases. This offers the advantage of using the smallest bearing sizes to obtain the least amount of friction. Fig. 3 shows the coefficient of friction increasing as surface velocity increases from 2-20 FPM (0.6-6.1m/min.)

CONTAMINATION

Fiberglide®/Fabroid® can tolerate small amounts of dirt, but reduced bearing life will result. Optimum life is achieved if dirt or abrasive particles are excluded. If a dirty environment is likely, we recommend installation of a simple seal.

RUNNING CLEARANCE

As a general rule, close running fits, and often slight interference fits (.0005 in., .013 mm) are selected for oscillating motion when minimum starting torque is less important than the elimination of free play. For constant rotation, a free-running fit is normally recommended, the exact amount depending on bearing bore size. A rule of thumb would be 0.0015 inches per inch (.038 mm) of bore (bearing installed).

BEARING HOUSING & SHAFT SIZING

Standard Fiberglide®/Fabroid® journal bearings (CJS/CJT/CJM/CJH/SJS Type) are installed into the housing bore using a press fit. Recommended housing bores should be held to the tolerance shown to insure the proper fit and size.

The LJS Type bearing is hand slip fit into its recommended housing bore to provide optimum fit-up. CJS/CJT/CJM/CJH types can also be provided for slip fits on special order.

Transport Dynamics offers a free service to properly recommend housing and shaft sizes for each new application. Contact Transport Dynamics engineering department for details.

FLUID COMPATIBILITY

Fiberglide®/Fabroid® can tolerate most fluids or contaminants found in bearing applications, although some reduction of dry bearing life will result. Fluids tend to flush PTFE solid particle lubricants out of the bearing. Grease tends to act as a magnet to attract and retain dirt. Following are some of the environments in which these bearings have operated successfully:

Hydraulic Oils	Ammonium hydroxide
Mild acids	Liquid Nitrogen
Greases	Seawater
Gasoline	Toluene
Lubricating oils	Kerosene
Detergent solutions	Water

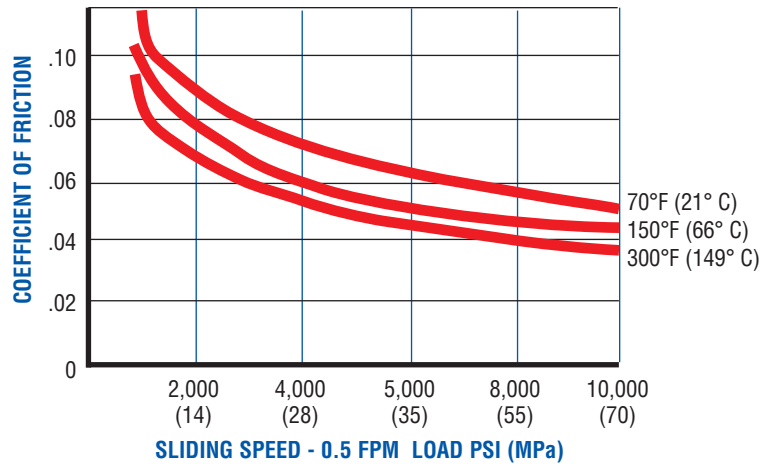

Fig. 1
Effect of load and temperature on Fiberglide® bearing

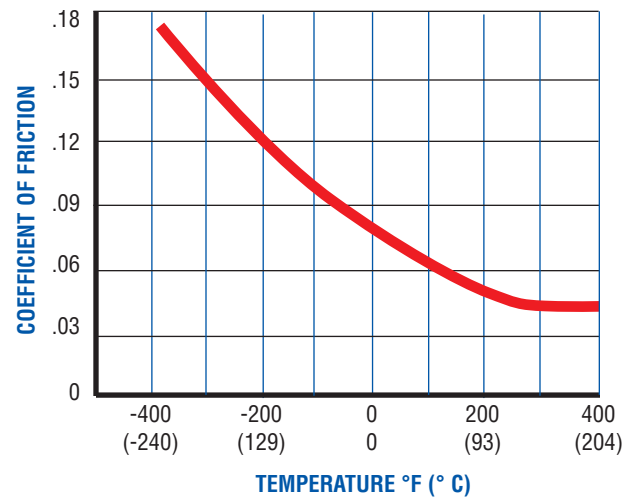

Fig. 2
Effect of temperature on coefficient of friction

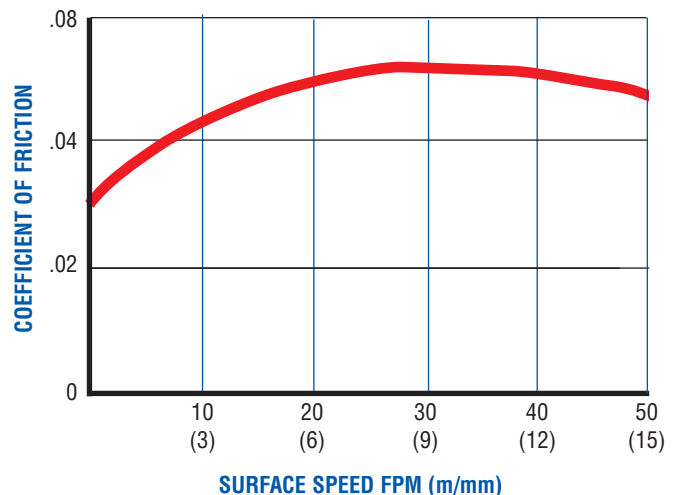

Fig. 3
Coefficient of friction at 10,000 psi. (70 MPa)
Normal unit load and 70°F (21°C) vs. surface speed

COMPARATIVE TESTING RESULTS

Tests were conducted to compare the load carrying capability and wear life of four standard self-lubricating bearing products. Transport Dynamics performed all testing on the same test machine and fixturing. Standard **Fiberglide®** and **Fabroid®** products are presented herein. Transport Dynamics offers other self-lubricating bearing products capable of dynamic loading to 40,000 psi (276 MPa) and ultimate static loading to 120,000 psi (827 MPa).

TEST CONDITIONS

The bearings were placed under a fixed load with an oscillating shaft. The test bearing size was 1.00 inch (25.4 mm) I.D. by .500 inch (12.7 mm) long. The test conditions were 10,000 psi (70 MPa) (5,000 lbs) (22kN) and 5,000 psi (35 MPa) (2,500 lbs) (11 kN) loads with an oscillation of ± 45 degrees and 30 cycles per minute at room temperature. Approximately every 10,000 cycles, the bearings were removed and inspected for wear.

Industrial Bearing Life Testing Cycles to Failure vs. Bearing Type

Total Life Cycles at 5,000 psi Load (35 MPa)

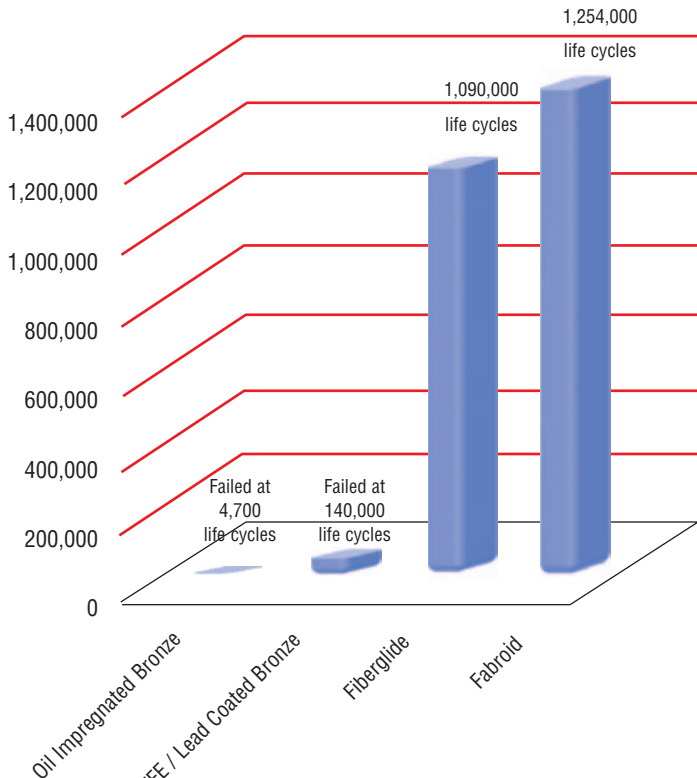

Test Condition:
5,000 PSI (35 MPa) (2,500 lbs.) (11kN) Journal Bearing
1.00 (25.4 mm) I.D. x .500 (12.7 mm) wide; oscillation $\pm 45^\circ$
30 CPM. Room Temperature.

Total Life Cycles at 10,000 psi Load (70 MPa)

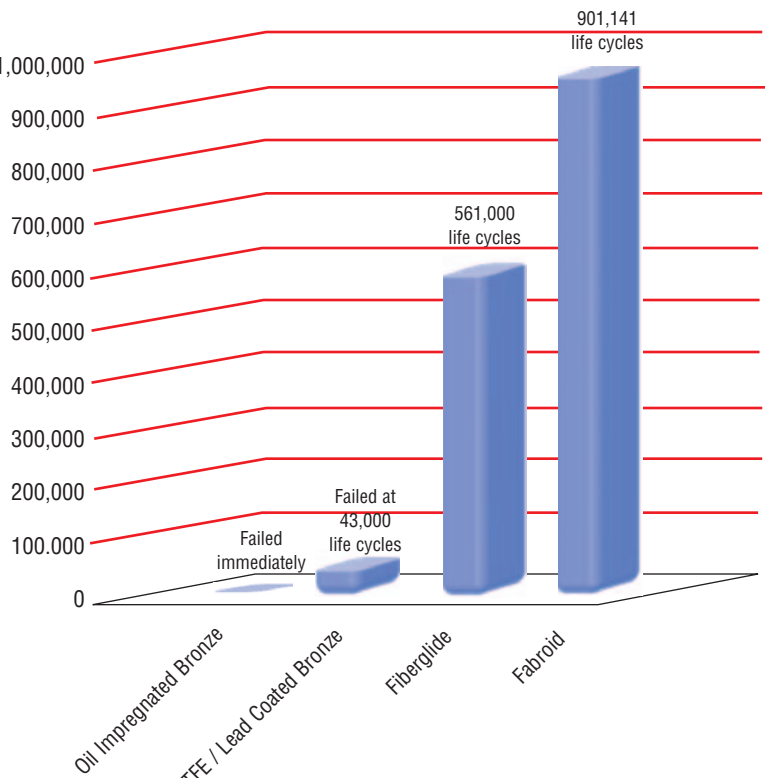

Test Condition:
10,000 PSI (70 MPa) (5,000 lbs.) (22kN) Journal Bearing
1.00 (25.4) I.D. x .500 (12.7 mm) wide; oscillation $\pm 45^\circ$
30 CPM. Room Temperature.

DU® is a registered trademark of GGB Inc.

COMPARATIVE TESTING RESULTS

Fiberglide®/Fabroid®

The graph below depicts typical wear curves for two types of self-lubricating liner materials; Standard Fiberglide® and Fabroid®. The standard Fiberglide® material is suitable for most applications and significantly outperforms other bearing types. But, should your

application include extraordinarily high static and/or dynamic loads, extreme temperatures, or chemical resistance requirements, Transport Dynamics manufactures a variety of liner materials and backing for critical service applications.

A Comparison of Fiberglide® and Fabroid® Bearings with Other Self-Lubricating Types

	METAL-BACKED Fiberglide®	METAL-BACKED FABROID®	FILLED PTFE	PTFE IMPREG-NATED BRONZE	OIL IMPREG-NATED BRONZE
TYP. DYNAMIC LOAD (psi)	2,000 TO 10,000 (14 TO 70 MPa)	5,000 TO 20,000 (34 TO 140 MPa)	0 TO 500 (0 TO 3.4 MPa)	500 TO 3,000 (3.4 TO 21 MPa)	100 TO 2,000 (.7 TO 14 MPa)
MAX. STATIC LOAD (psi)	38,000	60,000 ¹	10,000	20,000	11,000
MAXIMUM PV VALUE	50,000	60,000	10,000	50,000	50,000
TEMPERATURE RANGE (°F) (°C)	-320 (-195) +300 (145)	-320 (-195) +400 (204)	-400 (-240) +500 (260)	-320 (-195) +500 (260)	-65 (-54) +250 (121)
CHEMICAL RESISTANCE	GOOD	EXCELLENT	EXCELLENT	FAIR	POOR
MINIMUM COEFFICIENT OF FRICTION	.04	.03	.02	.03	.05

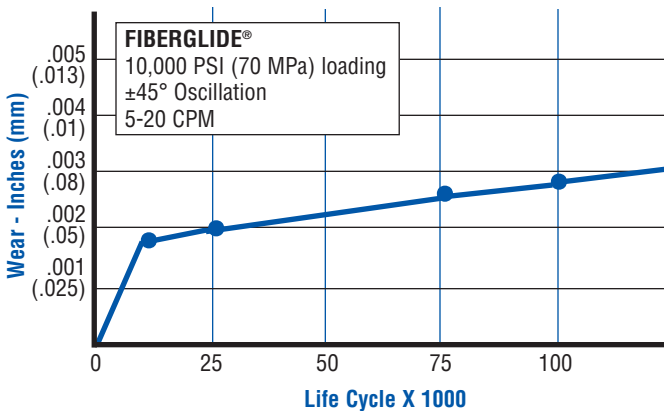

¹ FOR LOW SPEED OSCILLATING CONDITIONS - static loads over 38,000 PSI (262 MPa) or dynamic loads over 20,000 psi (140 MPa) require metal backing of high strength stainless steel or equivalent materials.

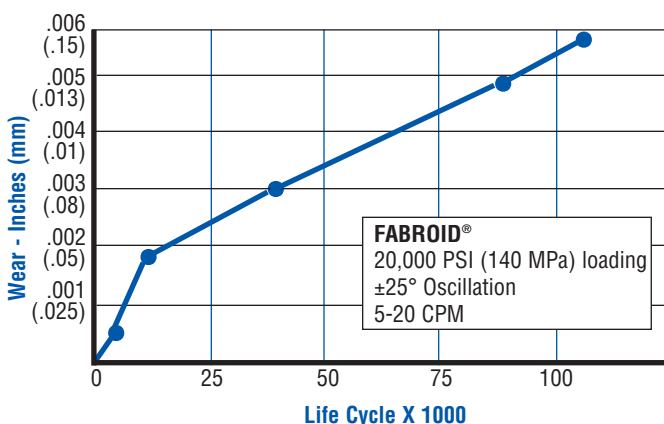

Transport Dynamics is the originator, innovator and leader in self-lubricating bearing technology with over fifty years of material development and application experience. The original Fabroid® Liner System was patented in 1958. Evolution in the development of materials has created three generations of self-lubrication liner technology.

Today's materials represent a significant advance in technology and their increased capabilities offer solutions in applications previously judged to be borderline or beyond material capability. Contact Transport Dynamics engineering department for a detail publication of all our 1 liner systems. Request Engineering Bulletin #106, Bearing Design Guide.

BEARINGS - INSTALLATION

Journal Bearings

Installation of solid journal bearings or closed seam coiled bearings (CJS, CJT, AND CJM series) should be accomplished with a stepped mandrel tool as illustrated. Housing bore should be provided with a lead-in chamfer. See Figure 1.

Entering corner of shaft must have a lead-in chamfer or radius as shown in Figure 2 to avoid damaging the bearing liner during assembly.

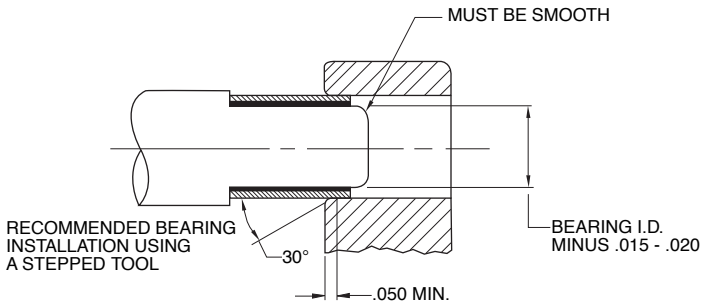

Fig. 1

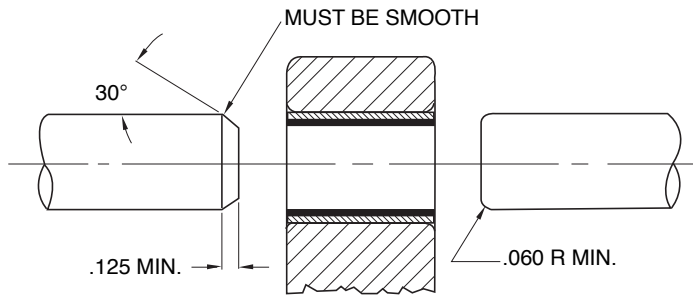

Fig. 2

When installation assembly design does not provide means for entrapment, liner type bearings (LJS series) should be positioned in the housing bore by undercutting the I.D. to form retaining steps as shown in figure 3 (upper). A separate sleeve type retainer, pressed into the housing, may be preferred in some cases as demonstrated in figure 3 (lower).

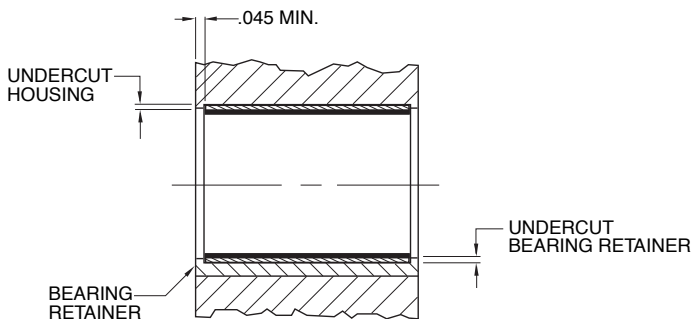

Fig. 3

Thrust Packs

Slim pack thrust bearings (FTP series) should be installed with the heavy wear washer on the bottom as indicated in Figure 4.

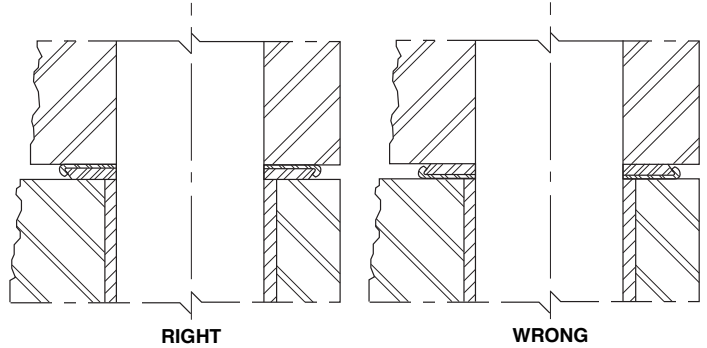

Fig. 4

When it is necessary to install this assembly below a heavy walled journal bearing, where repeated impact loads are involved, a special thrust pack having an enlarged liner plate I.D. may be preferred. See Figure 5.

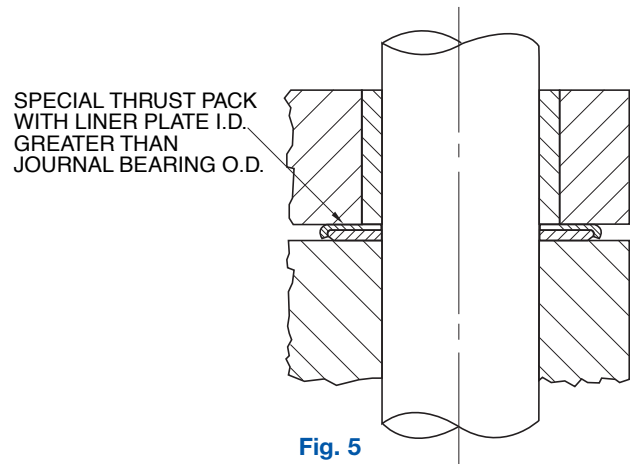

Fig. 5

Thrust Bearings

FTS/LTD series thrust bearings should run against a hard smooth-mating surface, which should be resistant to corrosion, otherwise moisture or high humidity tends to form surface rust.

Note that the standard I.D. dimensions are oversized in order to allow for corner radius of stepped shafts. See figure 6.

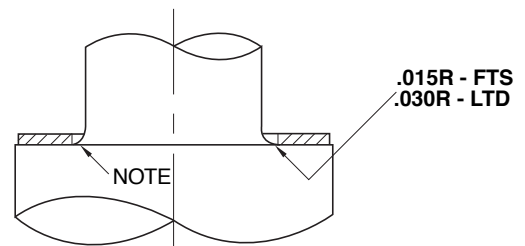

Fig. 6



Transport Dynamics

A Division of



BEARING APPLICATION DATA SHEET

COMPANY _____ DATE _____
STREET _____ CITY _____ STATE _____ ZIP _____
NAME _____ TITLE _____
PROJECT _____ PHONE () _____ EXT. _____
E-MAIL _____

IF PROPOSAL IS NOT TO BE SENT DIRECT TO ABOVE, STATE WHO AND WHERE

APPLICATION DESCRIPTION _____

NEW DESIGN [] REDESIGN [] BEARING NOW USED _____ P/N _____
REASON FOR CHANGE _____
TYPE OF BEARING: [] JOURNAL [] THRUST WASHER
[] SPHERICAL [] FLANGED JOURNAL [] OTHER _____

DESCRIPTION OF DUTY CYCLE (USE EXTRA SHEET IF NEEDED) _____

ENVIRONMENT (LIST CONTAMINATES AND/OR FLUIDS BEARINGS WILL BE EXPOSED TO) _____

DIMENSIONS:

HOUSING BORE ____ / ____ IN. SHAFT OR PIN O.D. ____ / ____ IN.
BEARING LENGTH OR BALL WIDTH _____ SHAFT MATERIAL _____ FINISH _____
WASHER ID _____ IN. OD _____ IN. THICKNESS _____ IN.

OPERATING TEMPERATURE RANGE LOW ____ °F HIGH ____ °F NORMAL ____ °F

LOAD: _____ LB. MAX STATIC OR IMPACT
_____ LB. MAX DYNAMIC
_____ LB. AVG. FOR DUTY CYCLE
_____ EST. PV (PSI X FPM)

LIFE DESIRED _____

SPEED: _____ MAX. RPM OR CYCLES PER MINUTE
_____ AVG. RPM OR CYCLES PER MINUTE
IF OSCILLATION, MAX. ANGLE _____ °
IF RECIPROCATING, MAX STROKE _____ IN.

Innovation. Commitment. Quality.

RBC Bearings has been producing bearings in the USA since 1919. In addition to unique custom bearings, RBC offers a full line of standard industrial and aerospace bearings, including:



Spherical Plain Bearings

Radial, angular contact, extended inner ring, high misalignment. QuadLube®, ImpactTuff®, SpreadLock® Seal, CrossLube®, DuraLube™, and self-lubricating bearings. Available in inch and metric sizes.



Thin Section Ball Bearings

Standard cross sections to one inch. Sizes to 40 inches. Stainless steel and other materials are available. Seals are available on all sizes and standard cross sections. Super duplex configurations.



Tapered Roller Bearings

Tyson® case-hardened and through-hardened tapered roller bearings. Available in many sizes. Used in Class 8 heavy truck and trailer wheel bearings, gear boxes, and final drive transmissions.



Tapered Roller Thrust Bearings

Case-hardened. Sealed and unsealed for truck, tractor, and construction equipment steer axles, and Class 8 trailer landing gear.



Integrated Assemblies

For robots and other process tool applications. Engineering design assistance. Production volume capacity.



Cam Followers

Standard stud, heavy stud, yoke type, caged roller followers. Patented RBC Roller® cylindrical roller cam followers, HexLube® universal cam followers, airframe track rollers.



Needle Roller Bearings

Pitchlign® caged heavy duty needle roller bearings, inner rings, TJ TandemRoller® bearings for long life.



Self-Lubricating Bearings

Radial, thrust, rod ends, spherical bearings, high temperature, high loads. Available in inch and metric sizes. Fiberglide®, Fabroid®, self-lubricating bearings.



Airframe Control Bearings

Ball bearing types, self-lubricating types, needle roller track rollers.



Dowel Pins, Loose Needle Rollers, Shafts

Precision Products dowel pins, loose needle rollers, and shafts.



Commercial Rod Ends

Commercial and industrial, precision, Mil-Spec series, self-lubricating, and aircraft. Sold under the Heim®, Unibal®, and Spherco® brands. Available in inch and metric sizes.



Ball Bearings

Precision ground, semi-ground, unground. High loads, long life, smooth operation. Nice® ball bearings are offered in caged and full complement configurations.



Specials

RBC manufactures many specialty bearings for the aerospace, oil and energy, semiconductor equipment, packaging, transportation, and other industries.