

# Rod Ends, Spherical Bearings, Self-Lubricating Bearings

**SPHERCO<sup>®</sup>**

The Brand You Know...The Brand You Trust.



**RBC<sup>®</sup>**  
BEARINGS

[www.rbcbearings.com](http://www.rbcbearings.com)  
800.390.3300

RBC Bearings Incorporated (RBC Bearings, RBC) has had a long tradition of innovation, commitment, and quality since the company was founded in 1919. Today, RBC Bearings has grown into a world-class manufacturer of standard and custom-engineered bearings and related products, with a product focus on research, testing, and development of the best product for specific applications.

## What We Manufacture

RBC Bearings, with facilities throughout North America and Europe, provides bearings and precision products for applications in the construction, mining, material handling, transportation and off-highway equipment, robotics and automation, farming, machine tool, and semiconductor equipment industries. Through RBC Aerospace Bearings, the company is a major manufacturer of highly-engineered bearings and precision products for military, defense, and commercial aerospace applications.

RBC's high-quality bearings include:

- **Heavy Duty Needle Roller Bearings** - Pitchlign® caged heavy duty needle roller bearings, inner rings, type TJ TandemRoller® bearings for long life.
- **Spherical Plain Bearings** - Radial, angular, contact, high misalignment, extended inner ring, DuraLube™ maintenance-free spherical plain bearings, QuadLube® long life bearings, ImpactTuff® case carburized bearings, ShimPack® double-acting angular contact bearings, CrossLube® lubrication groove systems, and SpreadLock® Seal.
- **Cam Followers and Yoke Rollers** - Standard stud, heavy stud, yoke type, caged roller followers, RBC Roller® long life cam followers, HexLube® universal cam followers, airframe track rollers. Mastguide rollers and carriage rollers, chain sheaves (for leaf chain), toothless sprockets (for roller chain), and heavy-duty roller bearing construction.
- **Rod Ends** - Commercial and aerospace, precision, Mil-Spec series, self-lubricating, inch and metric. Heim®, Unibal®, and Spherco® brands.
- **Self-Lubricating Bearings** - Radial, thrust, rod ends, spherical plain bearings, high temperature, high loads, inch and metric. Fiberglide® brand.
- **Thin Section Ball Bearings** - Standard cross sections to one inch. Sizes to 40 inches. Stainless steel and other materials available. Seals available on all sizes and standard cross sections.
- **Airframe Control Bearings** - Ball bearing types, self-lubricating types, needle rollers, track rollers.
- **Ground, Semiground, and Unground Ball Bearings** - Full complement, utilizes design and burnished races for higher loads, long life, and smooth operation.
- **Dowel Pins, Loose Needle Rollers, Shafts**
- **Tapered Roller and Tapered Thrust Bearings** - Case-hardened and through-hardened in a variety of sizes, used in Class 8 heavy truck and trailer wheel bearings, final drive transmissions and gear boxes.
- **Custom Designed Bearings** - RBC produces a wide range of custom bearings in various materials for specific applications.

## Spherco® Rod Ends

Spherco® offers a wide range of rod end types and sizes. Spherco®'s product range includes rod ends with brass race inserts in standard, precision and high capacity designs; high strength two-piece designs and self-lubricating rod end with engineered thermoplastic races or Teflon® liners with a wide range of optional features such as lubrication fittings, left hand threads, and keyway slots.

## Spherco® Spherical Bearings

Spherco® uses a wide variety of designs and materials to offer a comprehensive line of spherical bearings. Standard Spherco® Spherical Bearing designs include steel-on-steel precision spherical bearings with brass race inserts, high capacity and self-lubricating spherical bearings with Teflon® liners. Among the special bearings offered is the BTS LS Series.

## How We Can Serve You

RBC has implemented a total quality control system that uses statistical quality control at all facilities, and manufactures in high volume to a just-in-time program.

To serve the ongoing needs of customers, RBC has a network of over 1,600 distributors and sales engineers throughout North and South America and Europe, with authorized agents worldwide. For assistance with your bearing application, contact:

**Customer Service - 800.390.3300**

## Warranty

RBC products are warranted for material and workmanship for a period not to exceed 90 days from shipment and for a value not to exceed purchase price. No other warranty is in effect.

### Disclaimer and Intellectual Property Statement

The materials comprising this Catalog are provided by RBC Bearings Incorporated ("RBC Bearings, RBC") as a service to its customers on an "as-is" basis for informational purposes only. RBC assumes no responsibility for any errors or omissions in these materials. RBC makes no commitment to update the information contained herein.

RBC makes no, and expressly disclaims any, representations or warranties, express or implied, regarding the Catalog, including, without limitation, any implied warranties of merchantability or fitness for a particular purpose. RBC makes no, and expressly disclaims any, warranties, express or implied, regarding the correctness, accuracy, completeness, timeliness, and reliability of the text, graphics and any other items in the Catalog. Under no circumstances shall RBC, their affiliates, or any of their respective partners, officers, directors, employees, agents or representatives be liable for any damages, whether direct, indirect, special or consequential damages for lost revenues, lost profits, or otherwise, arising from or in connection with this Catalog and the materials contained herein.

All materials contained in the Catalog are protected by copyright laws, and may not be reproduced, republished, distributed, transmitted, displayed, broadcast or otherwise exploited in any manner without the express prior written permission of RBC.

RBC's names and logos and all related trademarks (including RBC Part Numbers, Series Number, and Cone and Cup Numbers), tradenames, and other intellectual property are the property of RBC Bearings and cannot be used without its express prior written permission.

Spherco® is a registered trademark of RBC Bearings.

Uniflon® is a registered trademark of Heim® Bearings Company.

Fiberglide® is a registered trademark of RBC Bearings.

Teflon® is a registered trademark of E.I. Du Pont de Nemours & Co.

# SPHERCO®

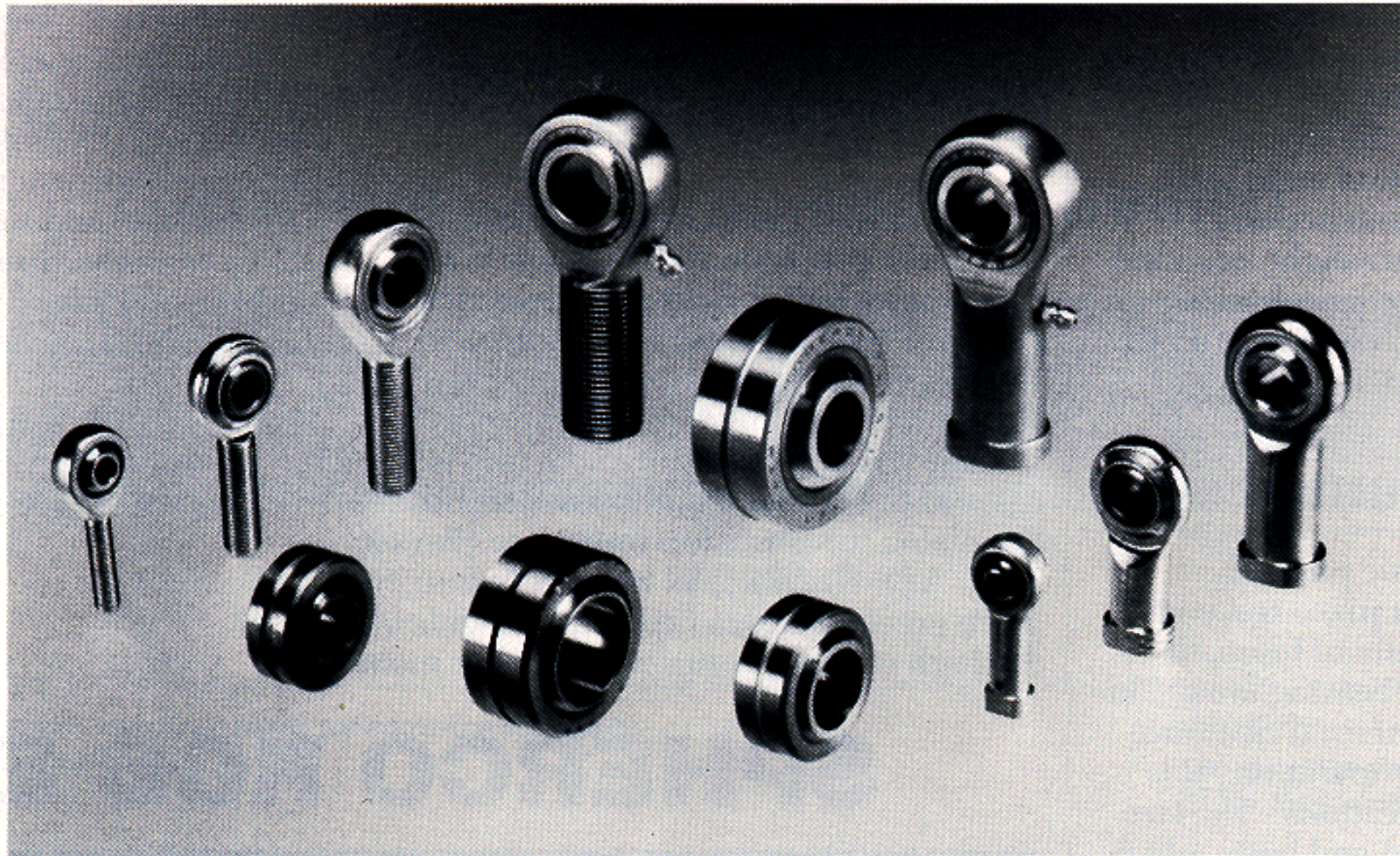

## TABLE OF CONTENTS

Page No.

### Rod Ends

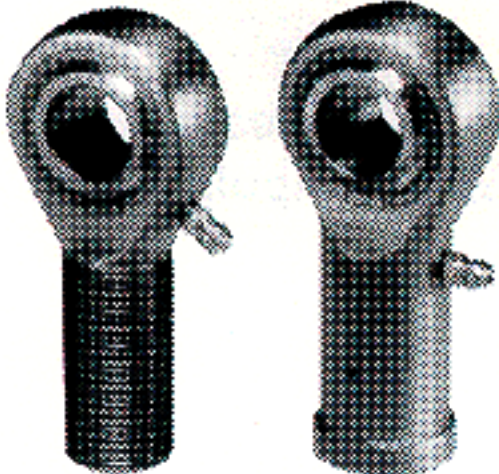
<b>Selection Guide</b> .....		2-3
 TRE, TR, ARE 20N, ARE, AR N	<b>Precision</b> .....	4-7
TM, TF, CFM, CFF	<b>Commercial</b> .....	8-11
CTMD, CTFD	<b>Engineered Thermoplastic Race</b> ..	12-13
<b>FEATURED PRODUCT</b> NOTES .....		14-15
CFM T, CFF T <b>New!</b>	<b>Self-Lubricating, Fiberglide®</b> ..	16-17
<b>Technical Section and Design Options</b> .....		18-21

### Spherical Bearings

<b>Selection Guide</b> .....		22-23
 FSBG, FLBG	<b>Precision</b> .....	24-25
SBG S, SBG, SBG SS, COR	<b>Precision</b> .....	26-27
COM, COM T, BH LS, BTS LS	<b>Commercial</b> .....	28-30
<b>Technical Section</b> .....		31-32



ROD ENDS

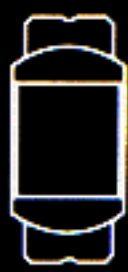

SPHERICAL

# S

pherco rod ends and spherical plain bearings are intended for linkage applications where a bearing must accommodate significant misalignment. While spherical plain bearings offer flexibility in housing and mounting design, the user bears the responsibility for housing design and the cost of housing manufacture. Rod ends offer greater mounting convenience and provide a compact, lightweight, economical design alternative to the spherical plain bearing. Spherco bearings offer the industry's widest selection of rod end types and sizes.

## Rod End Construction

Spherco offers three basic rod end constructions. The **four piece rod end** uses race inserts, typically of brass, to provide lubricity in the bearing area. This design offers reduced internal clearance and provides smoother operation. It is ideal for dynamic applications. The **two piece rod end** uses a rod end body which is formed around a spherical ball. The comparatively heavy cross section of the rod end body in the two piece design provides high strength. This makes the two piece rod end ideal for highly loaded, static applications where high strength is required. The **cartridge type rod end** consists of a spherical plain bearing mounted in a rod end body. This design allows the optimum selection of materials for ball, race and rod end body. The cartridge type rod end can also accommodate a PTFE liner for self-lubrication. This design is best suited for applications where lubrication is not practical.

## Self-lubricating Rod Ends

Spherco offers metal-to-metal rod ends and self-lubricating rod ends. All metal-to-metal rod ends, including brass insert four piece types, require regular lubrication. This can be accomplished by splash or immersion oil lubrication, or by greasing through optional lubricators (grease fittings). Self-lubricating types are used where relubrication is not practical or in applications where relubrication is not desirable such as on food processing machinery or in clean environments. Spherco self-lubricating rods ends are available with bonded PTFE fabric liners or with molded, engineered thermoplastic race inserts.

## Rod End Grades

Spherco rod ends are offered in three grades: precision, commercial and aircraft. **Precision** rod ends are manufactured to tight tolerances for applications requiring improved linkage accuracy and reduced looseness. **Commercial** rod ends are produced using standard materials

# SPHERCO®

and manufacturing methods, and are an economical choice for industrial applications. **Aircraft** rod ends use premium materials and have magnafluxed rod end bodies. Originally intended for aircraft applications, aircraft rod ends are used in many industrial applications where a high degree of reliability is required.

**Precision Rod Ends** Grade TRE and TR four piece precision rod ends use brass race inserts for lubricity and clearance control. They are produced to tight tolerances for applications requiring a more precise rod end; for example, a linkage where positioning accuracy is essential. These rod end bodies and balls are plated for corrosion resistance. Series ARE, ARE N, ARE 20N and AR N four piece precision extra capacity rod ends are the high strength series intended for more

heavily loaded, static and dynamic industrial applications. These rod ends have alloy steel heat treated bodies for increased strength and aluminum bronze race inserts for high bearing capacity. The rod end bodies are protective coated for corrosion resistance and the balls are heat treated and chrome plated for superior wear and corrosion resistance. Series ARE (male) and series AR N (female) have common thread sizes. Series ARE 20N (male) have oversized shanks for additional shank strength.

- Series TRE and TR: pages 4-5
- Series ARE, ARE 20N and AR N: pages 6-7

# SPHERCO ROD ENDS

## ROD END QUICK SELECTION GUIDE

Series Size Range	Product Features	Customer Benefits	Common Applications
TRE, TR 3/16" to 1"	Precision Grade, Brass Inserts, Four Piece Construction	Low Friction, Long Dynamic Life, Smooth Feel, Good Conformity	Control Linkages, For Reduced Play, Accelerator Linkages
ARE, ARE 20N, AR N, 1/4" to 3/4"	Precision Grade Aluminum Bronze Inserts, High Strength Body, Four Piece Construction	High Capacity Version	Heavy Duty Applications
TM, TF 3/16" to 3/4"	Commercial Grade Brass Inserts, Four Piece Construction	Low Friction, Long Dynamic Life, Smooth Feel, Good Conformity Cost Effective	Packaging Machine Linkages
CFM, CFF 3/16" to 3/4"	Commercial Grade Two Piece Construction	High Loads, Reversing Loads, Shock Loads, Cost Effective	Brake and Clutch Pedals For Heavy Machinery, Satellite Dish Controls
CTMD, CTFD 3/16" to 3/4"	Commercial Grade Self-Lubricating Thermoplastic Race	Maintenance Free Virtually No Radial Clearance, Dimensional Stability	Food Processing, Paper Machinery, Bus Door Closures, Marine Applications
CFM T, CFF T 1/4" to 5/8"	Commercial Grade Self-Lubricating Fiberglide®	Maintenance Free, High Loads, Reversing Loads, Shock Loads, Cost Effective	Packaging Machines, Robotics, Textile Equipment, Hydraulic Cylinders

ROD ENDS

## SPHERICAL BEARINGS CONSUMER GUIDE

- Best
- ⊖ Better
- Good
- ✓ Yes

SPHERCO SERIES	PAGE	LOADING				PRECISION	CORROSION RESISTANCE	SELF-LUBRICATING	MAXIMUM TEMPERATURE	SIZE RANGE	RACE MATERIAL	DESIGN
		STATIC	OSCILLATING	REVERSING	SHOCK							
TRE TR	4-5	⊖	⊖	○	○			250°F	3/16" b 1"	BRASS		
ARE AR N ARE 20N	6-7	●	●	●	⊖			250°F	1/4" b 3/4"	ALUMINUM BRONZE		
TM TF	8-9	⊖	⊖	○	○			250°F	3/16" b 3/4"	BRASS	FOUR PIECE	
CFM CFF	10-11	⊖	○	⊖	●			250°F	3/16" b 3/4"	STEEL	TWO PIECE	
CTMD CTFD	12-13	○	⊖	○	○		✓	125°F	3/16" b 3/4"	THERMO- PLASTIC	MOLDED RACE	
CFM T CFF T	18-19	⊖	●	●	⊖		✓	250°F	1/4" b 3/4"	FIBERGLIDE®	THREE PIECE	

**Commercial Rod Ends Series TM and TF** four piece commercial rod ends use Spherco's classic brass race insert design for lubricity and clearance control. These rod ends are preferred for dynamic applications. Spherco commercial rod ends have zinc plated bodies and nickel plated balls for corrosion resistance.

- Series TM and TF: pages 8-9

Series CFM and CFF two piece commercial rod ends offer high strength for heavy static loads. Heim's unique manufacturing process for two piece rod ends yields the industry's best conformity between ball and body for maximum bearing capacity.

- Series CFM and CFF: pages 10-11

Series CTMD and CTFD self-lubricating commercial rod ends use an engineered thermoplastic race for applications where relubrication is not practical or desirable. The rod end body and ball are plated for corrosion resistance. This series is also available in stainless steel for superior corrosion resistance.

- Series CTMD and CTFD: pages 12-13

### Optional Rod End Features

Spherco rod ends are available with male and female threaded shanks. Standard rod ends have right hand threads. Left hand threads are available as an option. Lubricators are standard on selected series and are available as an option on all other series. Shank keyways are optional on most series to engage lock washer tangs. A wide range of other optional features includes plain shanks, special plating, longer or shorter shanks, and tighter radial clearance.

### FEATURED PRODUCT

The CFM T and CFF T Series utilize the two piece rod end manufacturing process and a durable Fiberglide® liner system. This series offers a high strength rod end with a long lasting, self-lubricating liner. Radial clearance is minimal while rotating torque is low.

- Series CFM T and CFF T: pages 16-17



# SPHERCO®

## Precision Series Four Piece - Metal to Metal

### Series TRE

ROD END NUMBER	DIMENSIONS IN INCHES									MAXIMUM STATIC RADIAL LOAD LBF	APPROX WEIGHT LBS
	BORE	BALL WIDTH	HOUSING WIDTH	HEAD DIAMETER	LENGTH TO CENTER OF BALL	THREAD LENGTH	THREAD SIZE	BALL DIAMETER	BALL FLAT DIAMETER		
	B	W	H ④	D	F	A	M	E	O		
	+ .0015 - .0005	+ .000 - .005	+ .005 - .005	+ .010 - .010	+ .031 - .031	+ .062 - .031	UNF-3A	REF	REF		
TRE3	.1900	.312	.250	.625	1.250	.750	.1900-32	.437	.306	900	.03
TRE4	.2500	.375	.281	.750	1.562	1.000	.2500-28	.515	.353	1,700	.05
TRE5	.3125	.437	.344	.875	1.875	1.250	.3125-24	.625	.447	2,500	.08
TRE6	.3750	.500	.406	1.000	1.938	1.250	.3750-24	.718	.516	4,000	.12
TRE7	.4375	.562	.437	1.125	2.125	1.375	.4375-20	.812	.586	5,000	.17
TRE8	.5000	.625	.500	1.312	2.438	1.500	.5000-20	.937	.698	7,000	.26
TRE10	.6250	.750	.562	1.500	2.625	1.625	.6250-18	1.125	.839	8,050	.41
TRE12	.7500	.875	.687	1.750	2.875	1.750	.7500-16	1.312	.978	11,300	.64
TRE16	1.0000	1.375	1.000 ⑤	2.750 ⑤	4.125	2.125	1.2500-12	1.875	1.269	28,400	2.25

Outer Member: Carbon steel, with protective coating for corrosion resistance

Ball: 52100 Alloy steel, heat treated, chrome plated

Inserts: Brass  
16 size has a one piece carbon steel race

#### NOTES

- ① Add letter "L" to prefix to indicate Left Hand thread  
Example: TREL4
- ② For design options, see page 21
- ③ For Engineering data, see pages 18 thru 20
- ④ "H" tolerance across inserts is +/- .015
- ⑤ Tolerances for 16 size: "D" +.030  
-.010  
"H" +.030  
-.010

ROD ENDS

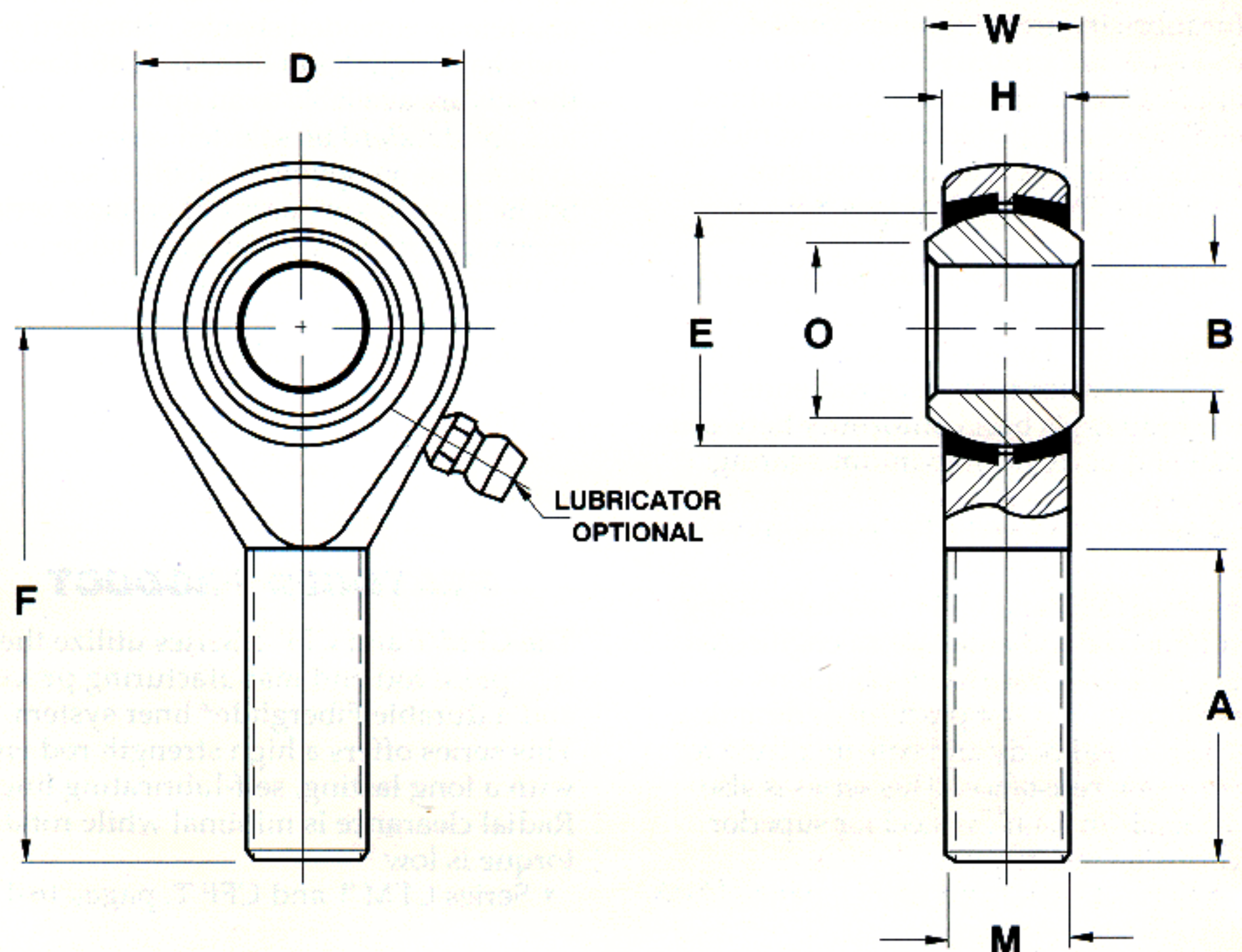

# SPHERCO®

## Precision Series Four Piece - Metal to Metal

### Series TR

ROD END NUMBER	DIMENSIONS IN INCHES												MAXIMUM STATIC RADIAL LOAD LBF	APPROX WEIGHT LBS
	BORE	BALL WIDTH	HOUSING WIDTH	HEAD DIAMETER	LENGTH TO CENTER OF BALL	THREAD LENGTH	THREAD SIZE	BALL DIAMETER	BALL FLAT DIAMETER	ACROSS WRENCH FLATS	OTHER DIMENSIONS			
	B	W	H ④	D	F	A	M	E	O	J	K	L		
	+0.0015 -0.0005	+0.000 -0.005	+0.005 -0.005	+0.010 -0.010	+0.031 -0.031	+0.062 -0.031	UNF-3B	REF	REF	+0.010 -0.010	+0.010 -0.010	+0.010 -0.010		
TR3	.1900	.312	.250	.625	1.062	.562	.1900-32	.437	.306	.312	.406	.187	1,850	.03
TR4	.2500	.375	.281	.750	1.312	.750	.2500-28	.515	.353	.375	.468	.187	2,700	.05
TR5	.3125	.437	.344	.875	1.375	.750	.3125-24	.625	.447	.437	.500	.187	3,350	.08
TR6	.3750	.500	.406	1.000	1.625	.937	.3750-24	.718	.516	.562	.687	.250	4,450	.12
TR7	.4375	.562	.437	1.125	1.812	1.062	.4375-20	.812	.586	.625	.750	.250	5,350	.17
TR8	.5000	.625	.500	1.312	2.125	1.187	.5000-20	.937	.698	.750	.875	.250	7,400	.26
TR10	.6250	.750	.562	1.500	2.500	1.500	.6250-18	1.125	.839	.875	1.000	.312	8,050	.41
TR12	.7500	.875	.687	1.750	2.875	1.750	.7500-16	1.312	.978	1.000	1.125	.312	11,300	.64
TR16	1.0000	1.375	1.000 ⑤	2.750 ⑤	4.125	2.125	1.2500-12	1.875	1.275	1.500 ⑤	1.625 ⑤	.437 ⑤	28,400	2.25

**Outer Member:** Carbon steel, with protective coating for corrosion resistance

**Ball:** 52100 Alloy steel, heat treated, chrome plated

**Inserts:** Brass  
16 size has a one piece carbon steel race

#### NOTES

- ① Add letter "L" to prefix to indicate Left Hand thread  
Example: TRL 4
- ② For design options, see page 21
- ③ For Engineering data, see pages 18 thru 20
- ④ "H" tolerance across inserts is +/- .015
- ⑤ Tolerances for 16 size: "D" +.030  
-.010  
"H" +.030  
-.010  
"K", "J", "L" +/- .015

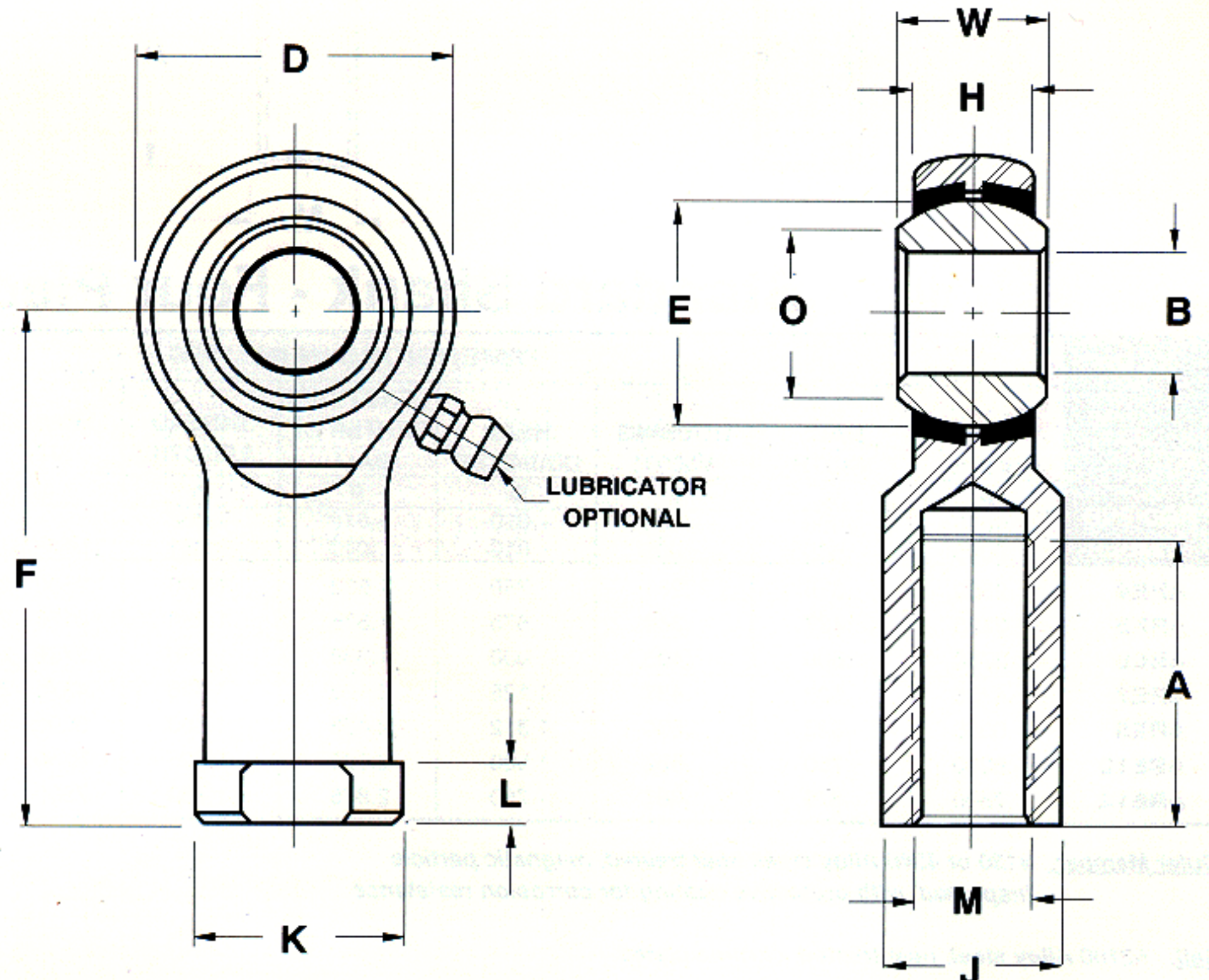
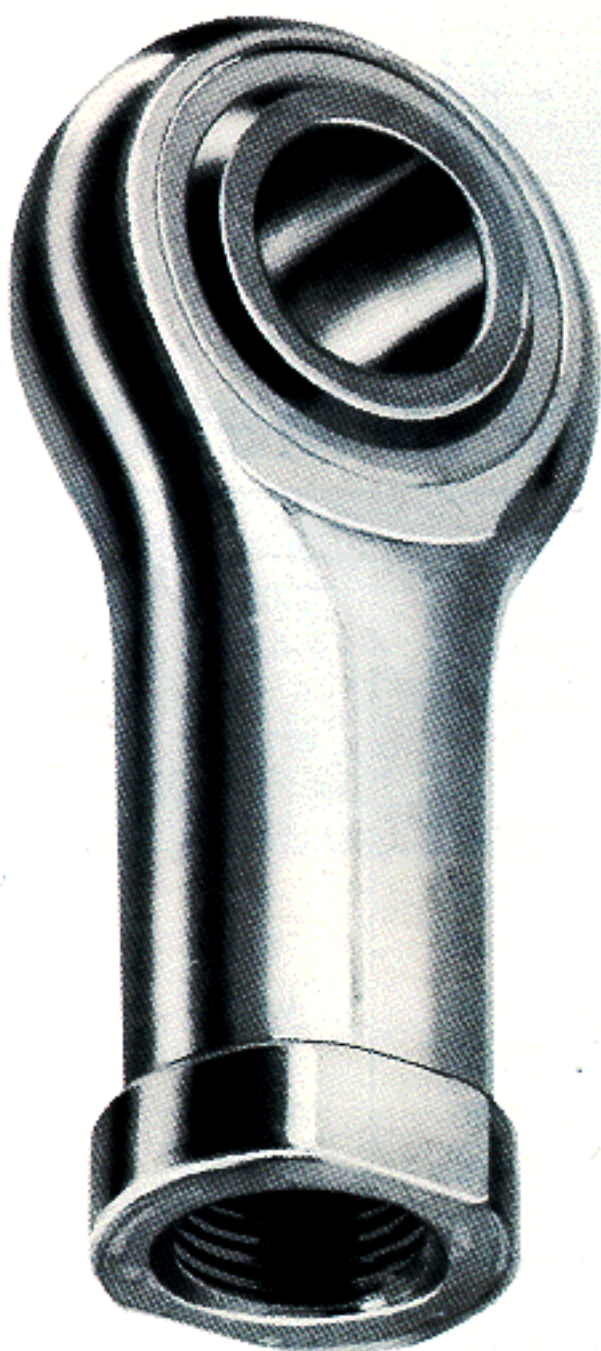

ROD ENDS

# SPHERCO®

## Precision Extra Capacity Series Oversize Shank - Four Piece - Metal to Metal

### Series ARE 20N

ROD END NUMBER	DIMENSIONS IN INCHES									MAXIMUM STATIC RADIAL LOAD		APPROX WEIGHT
	BORE	BALL WIDTH	HOUSING WIDTH	HEAD DIAMETER	LENGTH TO CENTER OF BALL	THREAD LENGTH	THREAD SIZE	BALL DIAMETER	BALL FLAT DIAMETER	WITH LUBRICATOR	WITHOUT LUBRICATOR	
	B	W	H ④	D	F	A	M	E	O	LBF		LBS
	+ .0015 - .0005	+ .000 - .005	+ .005 - .005	+ .010 - .010	+ .010 - .010	+ .062 - .031	UNF-3A	REF	REF			
ARE420N	.2500	.375	.281	.750	1.562	1.000	.3125-24	.515	.353	3,260	6,680	.06
ARE520N	.3125	.437	.344	.875	1.875	1.250	.3750-24	.625	.447	4,920	8,410	.09
ARE620N	.3750	.500	.406	1.000	1.938	1.250	.4375-20	.718	.516	7,240	11,160	.13
ARE720N	.4375	.562	.437	1.125	2.125	1.375	.5000-20	.812	.586	7,620	13,660	.18
ARE820N	.5000	.625	.500	1.312	2.438	1.500	.6250-18	.937	.698	11,920	19,340	.30
ARE1020N	.6250	.750	.562	1.500	2.625	1.625	.7500-16	1.125	.839	13,940	21,080	.46
ARE1220N	.7500	.875	.687	1.750	2.875	1.750	.8750-14	1.312	.978	21,570	29,800	.72

**Outer Member:** 4130 or 4340 Alloy steel, heat treated, magnetic particle inspected, with protective coating for corrosion resistance

**Ball:** 52100 Alloy steel, heat treated, chrome plated

**Inserts:** Copper alloy

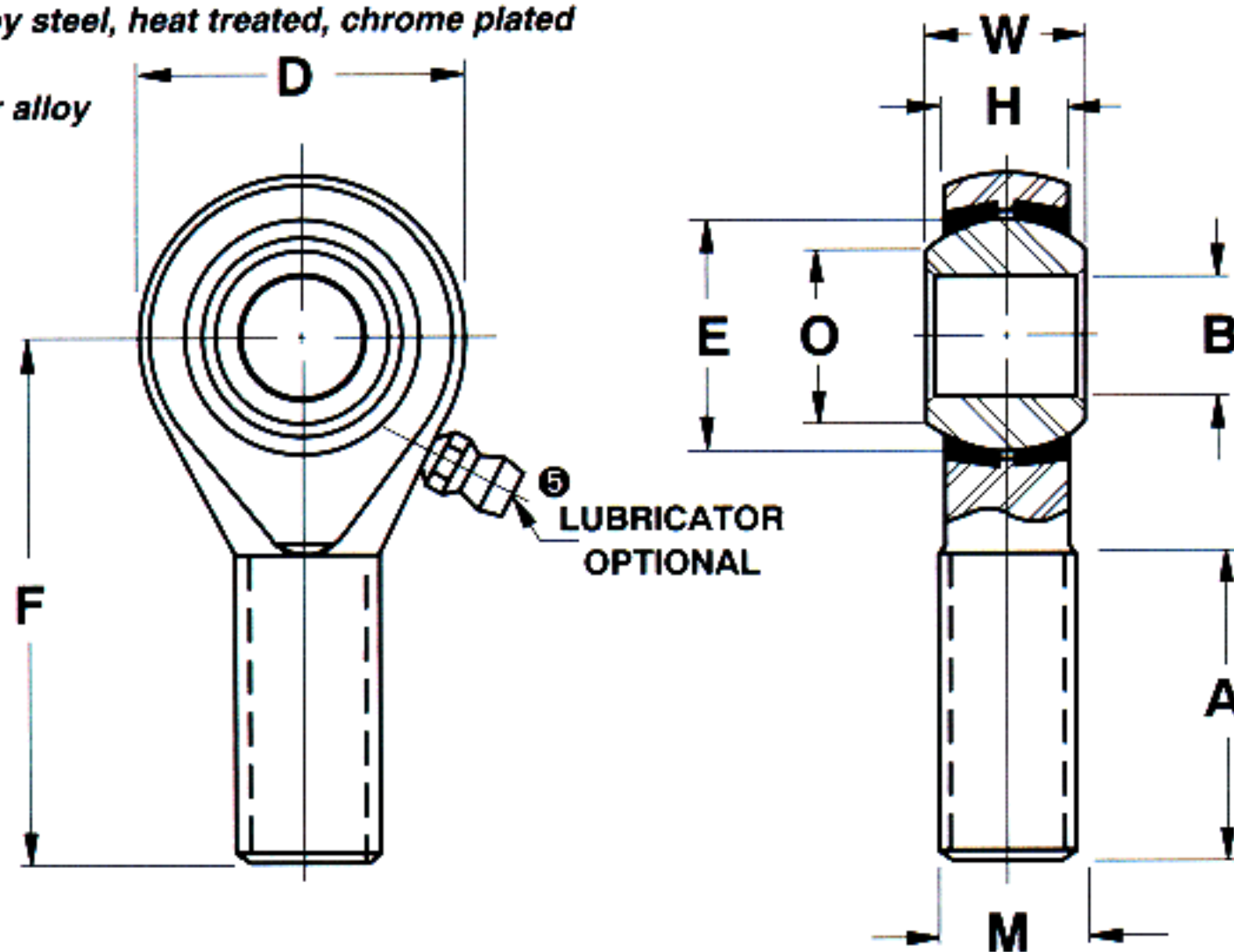

#### NOTES

- ① Add letter "L" to prefix to indicate Left Hand thread  
Example: AREL420N
- ② For design options, see page 21
- ③ For Engineering data, see pages 18 thru 20
- ④ "H" tolerance across inserts is +/- .015
- ⑤ Delete letter "N" from suffix to indicate no lubricator  
Example: ARE420



## Standard Shank - Four Piece - Metal to Metal

ROD END NUMBER	DIMENSIONS IN INCHES									MAXIMUM STATIC RADIAL LOAD		APPROX WEIGHT
	BORE	BALL WIDTH	HOUSING WIDTH	HEAD DIAMETER	LENGTH TO CENTER OF BALL	THREAD LENGTH	THREAD SIZE	BALL DIAMETER	BALL FLAT DIAMETER	WITHOUT LUBRICATOR		
	B	W	H ④	D	F	A	M ⑥	E	O	LBF	LBS	
	+ .0015 - .0005	+ .000 - .005	+ .005 - .005	+ .010 - .010	+ .010 - .010	+ .062 - .031	UNF-3A	REF	REF			
ARE4	.2500	.375	.281	.750	1.562	1.000	.2500 - 28	.515	.353	4,290		.05
ARE5	.3125	.437	.344	.875	1.875	1.250	.3125 - 24	.625	.447	6,880		.08
ARE6	.3750	.500	.406	1.000	1.938	1.250	.3750 - 24	.718	.516	10,500		.12
ARE7	.4375	.562	.437	1.125	2.125	1.375	.4375 - 20	.812	.586	13,660		.17
ARE8	.5000	.625	.500	1.312	2.438	1.500	.5000 - 20	.937	.698	19,340		.26
ARE10	.6250	.750	.562	1.500	2.625	1.625	.6250 - 18	1.125	.839	21,080		.41
ARE12	.7500	.875	.687	1.750	2.875	1.750	.7500 - 16	1.312	.978	29,800		.64

**Outer Member:** 4130 or 4340 Alloy steel, heat treated, magnetic particle inspected, with protective coating for corrosion resistance

**Ball:** 52100 Alloy steel, heat treated, chrome plated

**Inserts:** Copper alloy

#### NOTES

- ① Add letter "L" to prefix to indicate Left Hand thread  
Example: AREL4
- ② For design options, see page 21
- ③ For Engineering data, see pages 18 thru 20
- ④ "H" tolerance across inserts is +/- .015
- ⑤ Lubricator optional on ARE series  
Example: ARE4N
- ⑥ ARE has same thread size as AR N series



# SPHERCO®

## Precision Extra Capacity Series Standard Thread -Four Piece - Metal to Metal

### Series AR N

ROD END NUMBER	DIMENSIONS IN INCHES													MAXIMUM STATIC RADIAL LOAD		APPROX WEIGHT LBS
	BORE	BALL WIDTH	HOUSING WIDTH	HEAD DIAMETER	LENGTH TO CENTER OF BALL	THREAD LENGTH	THREAD SIZE	BALL DIAMETER	BALL FLAT DIAMETER	ACROSS WRENCH FLATS	OTHER DIMENSIONS			WITH LUBRICATOR	WITHOUT LUBRICATOR	
	B	W	H ④	D	F	A	M ⑥	E	O	J	K	N	L	LBF	LBS	
	+0.015 -0.005	+0.000 -0.005	+0.005 -0.005	+0.010 -0.010	+0.010 -0.010	+0.062 -0.031	UNF-3B	REF	REF	+0.010 -0.010	+0.010 -0.010	+0.020 -0.020	+0.010 -0.010			
AR4N	.2500	.375	.281	.750	1.312	.750	.2500 - 28	.515	.355	.375	.468	.312	.187	3,260	6,680	.06
AR5N	.3125	.437	.344	.875	1.375	.750	.3125 - 24	.625	.447	.437	.500	.406	.187	4,920	8,410	.08
AR6N	.3750	.500	.406	1.000	1.625	.937	.3750 - 24	.718	.517	.562	.687	.469	.250	7,240	11,160	.14
AR7N	.4375	.562	.437	1.125	1.812	1.062	.4375 - 20	.812	.586	.625	.750	.531	.250	7,620	13,660	.18
AR8N	.5000	.625	.500	1.312	2.125	1.187	.5000 - 20	.937	.698	.750	.875	.594	.250	11,920	19,340	.29
AR10N	.6250	.750	.562	1.500	2.500	1.500	.6250 - 18	1.125	.839	.875	1.000	.750	.312	13,940	21,080	.43
AR12N	.7500	.875	.687	1.750	2.875	1.750	.7500 - 16	1.312	.978	1.000	1.125	.875	.312	21,570	29,800	.64

**Outer Member:** 4130 or 4340 Alloy steel, heat treated, magnetic particle inspected, with protective coating for corrosion resistance

**Ball:** 52100 Alloy steel, heat treated, chrome plated

**Inserts:** Copper alloy

#### NOTES

- ① Add letter "L" to prefix to indicate Left Hand thread.  
Example: ARL4N
- ② For design options, see page 21
- ③ For Engineering data, see pages 18 thru 20
- ④ "H" tolerance across inserts is +/-0.015
- ⑤ Delete letter "N" from suffix on AR N Series to indicate no lubricator  
Example: AR 4
- ⑥ AR N series has same thread size as ARE series.

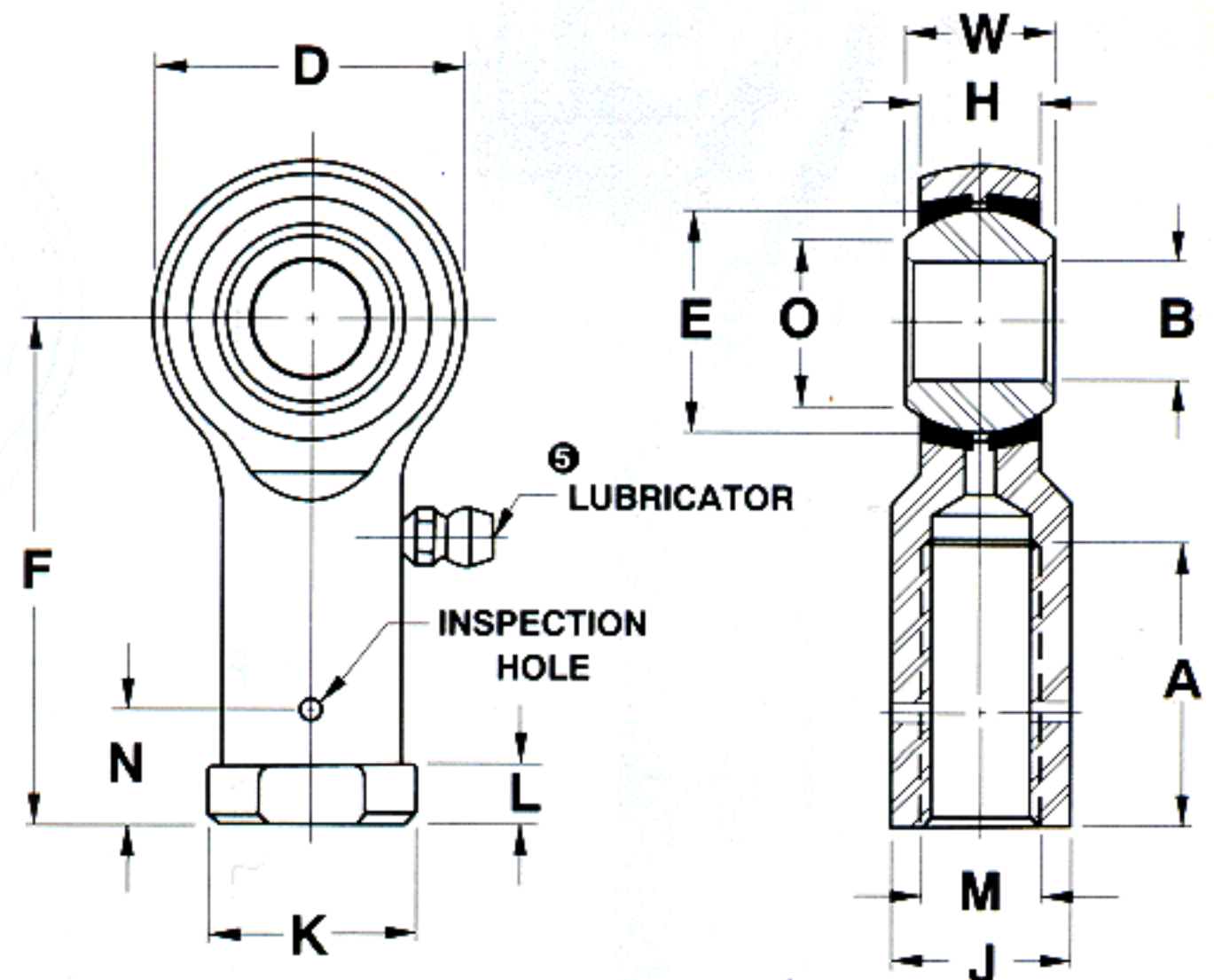
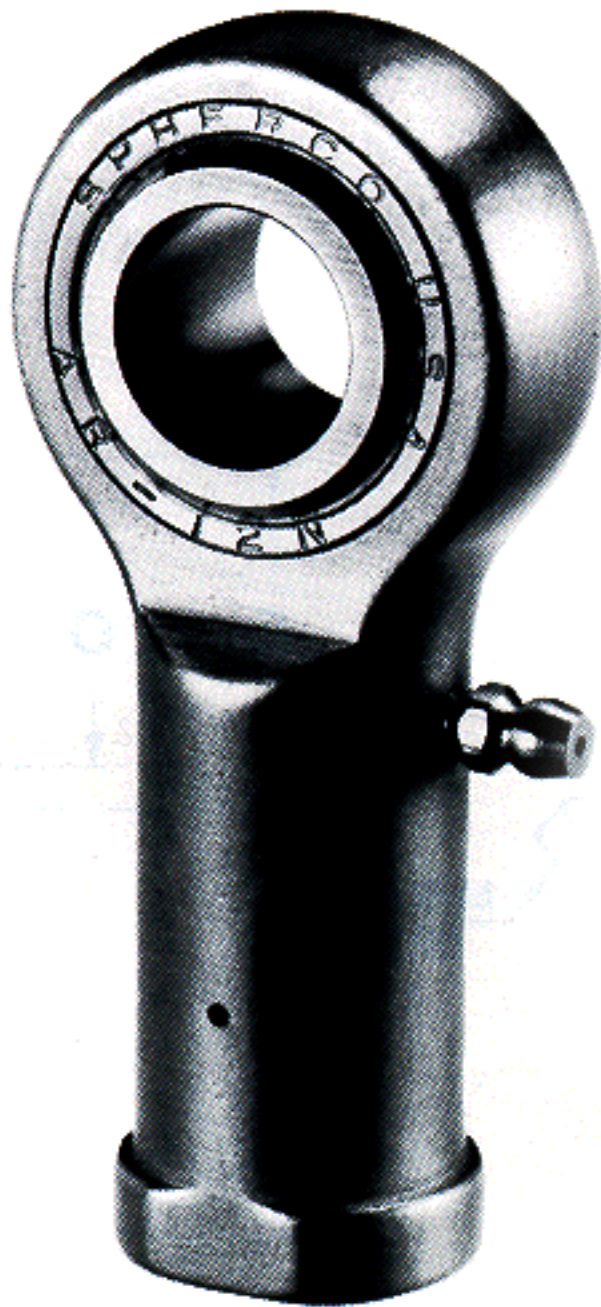

ROD ENDS

# SPHERCO®

## Commercial Series Four Piece - Metal to Metal

### Series TM

ROD END NUMBER	DIMENSIONS IN INCHES									MAXIMUM STATIC RADIAL LOAD LBF	APPROX WEIGHT LBS
	BORE	BALL WIDTH	HOUSING WIDTH	HEAD DIAMETER	LENGTH TO CENTER OF BALL	THREAD LENGTH	THREAD SIZE	BALL DIAMETER	BALL FLAT DIAMETER		
	B	W	H ④	D	F	A	M	E	O		
	+ .0025 - .0005	+ .005 - .005	+ .010 - .010	+ .031 - .031	+ .031 - .031	+ .062 - .062	UNF -3A	REF	REF		
TM3	.1900	.312	.250	.625	1.250	.750	.1900 - 32	.437	.306	900	.03
TM4	.2500	.375	.281	.750	1.562	1.000	.2500 - 28	.515	.353	1,700	.05
TM5	.3125	.437	.344	.875	1.875	1.250	.3125 - 24	.625	.447	2,500	.08
TM6	.3750	.500	.406	1.000	1.938	1.250	.3750 - 24	.718	.516	4,000	.12
TM7	.4375	.562	.437	1.125	2.125	1.375	.4375 - 20	.812	.586	5,000	.17
TM8	.5000	.625	.500	1.312	2.438	1.500	.5000 - 20	.937	.698	7,000	.25
TM10	.6250	.750	.562	1.500	2.625	1.625	.6250 - 18	1.125	.839	8,050	.41
TM12	.7500	.875	.687	1.750	2.875	1.750	.7500 - 16	1.312	.978	11,300	.64

**Outer Member:** Carbon steel, with protective coating for corrosion resistance

**Ball:** Carbon steel, case hardened, with protective coating for additional hardness and corrosion resistance

**Inserts:** Brass

#### NOTES

- ① Add letter "L" to prefix to indicate Left Hand thread  
Example: TML4
- ② For design options, see page 21
- ③ For Engineering data, see pages 18 thru 20
- ④ "H" tolerance across inserts is +/- .015

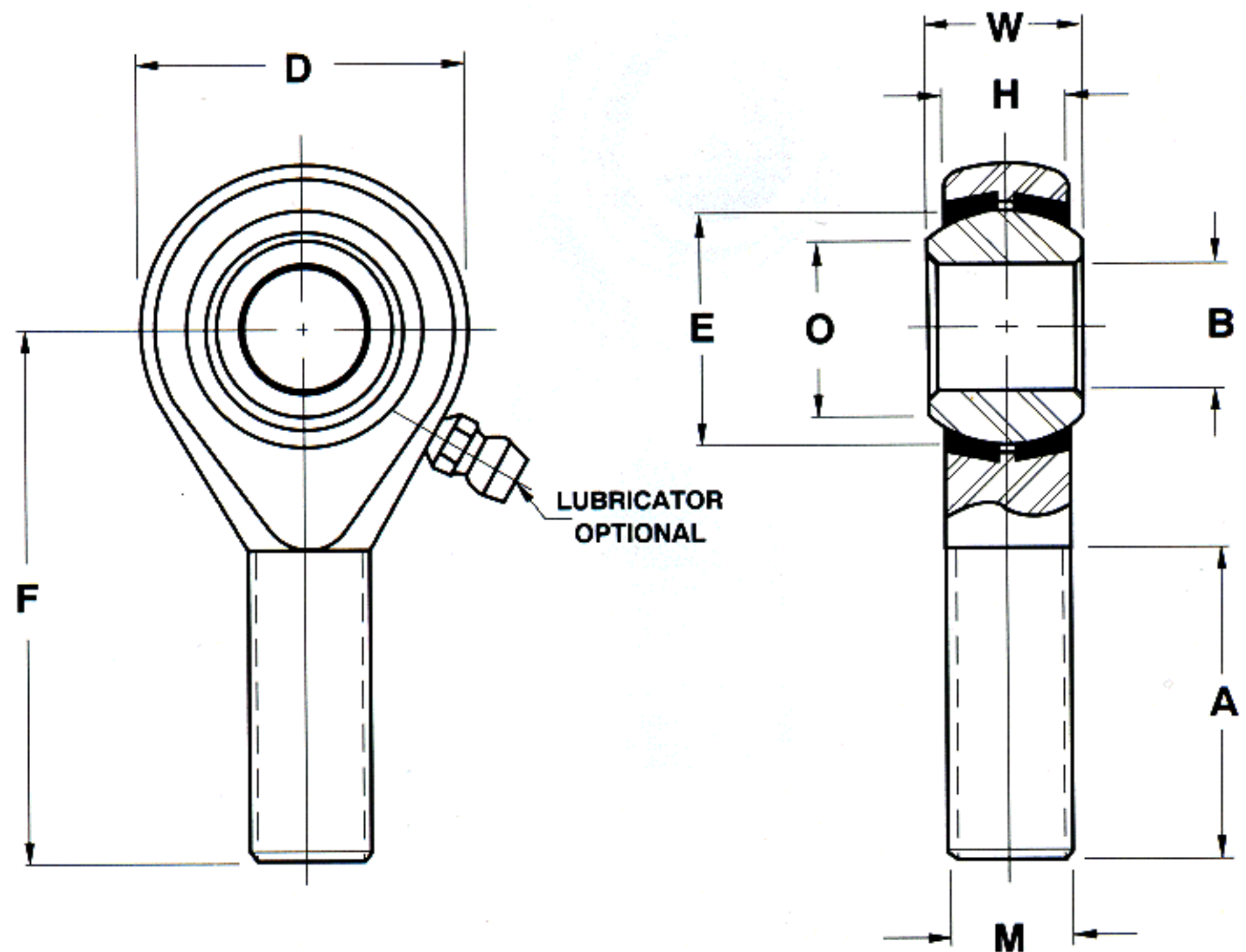

ROD ENDS

# SPHERCO®

## Commercial Series Four Piece - Metal to Metal

### Series TF

ROD END NUMBER	DIMENSIONS IN INCHES												MAXIMUM STATIC RADIAL LOAD	APPROX WEIGHT
	BORE	BALL WIDTH	HOUSING WIDTH	HEAD DIAMETER	LENGTH TO CENTER OF BALL	THREAD LENGTH	THREAD SIZE	BALL DIAMETER	BALL FLAT DIAMETER	ACROSS WRENCH FLATS	OTHER DIMENSIONS			
	B	W	H ④	D	F	A	M	E	O	J	K	L		
	+0.0025 -0.0005	+0.005 -0.005	+0.010 -0.010	+0.031 -0.031	+0.031 -0.031	+0.062 -0.062	UNF-3B	REF	REF	+0.010 -0.010	+0.010 -0.010	+0.010 -0.010	LBF	LBS
<b>TF3</b>	.1900	.312	.250	.625	1.062	.562	.1900-32	.437	.306	.312	.406	.187	1,850	.03
<b>TF4</b>	.2500	.375	.281	.750	1.312	.750	.2500-28	.515	.353	.375	.468	.187	2,700	.05
<b>TF5</b>	.3125	.437	.344	.875	1.375	.750	.3125-24	.625	.447	.437	.500	.187	3,350	.08
<b>TF6</b>	.3750	.500	.406	1.000	1.625	.937	.3750-24	.718	.516	.562	.687	.250	4,450	.12
<b>TF7</b>	.4375	.562	.437	1.125	1.812	1.062	.4375-20	.812	.586	.625	.750	.250	5,350	.17
<b>TF8</b>	.5000	.625	.500	1.312	2.125	1.187	.5000-20	.937	.698	.750	.875	.250	7,400	.26
<b>TF10</b>	.6250	.750	.562	1.500	2.500	1.500	.6250-18	1.125	.839	.875	1.000	.312	8,050	.41
<b>TF12</b>	.7500	.875	.687	1.750	2.875	1.750	.7500-16	1.312	.978	1.000	1.125	.312	11,300	.64

**Outer Member:** Carbon steel, with protective coating for corrosion resistance

**Ball:** Carbon steel, case hardened, with protective coating for additional hardness and corrosion resistance

**Inserts:** Brass

#### NOTES

- ① Add letter "L" to prefix to indicate Left Hand thread  
Example: TFL4
- ② For design options, see page 21
- ③ For Engineering data, see pages 18 thru 20
- ④ "H" tolerance across inserts is +/-0.015

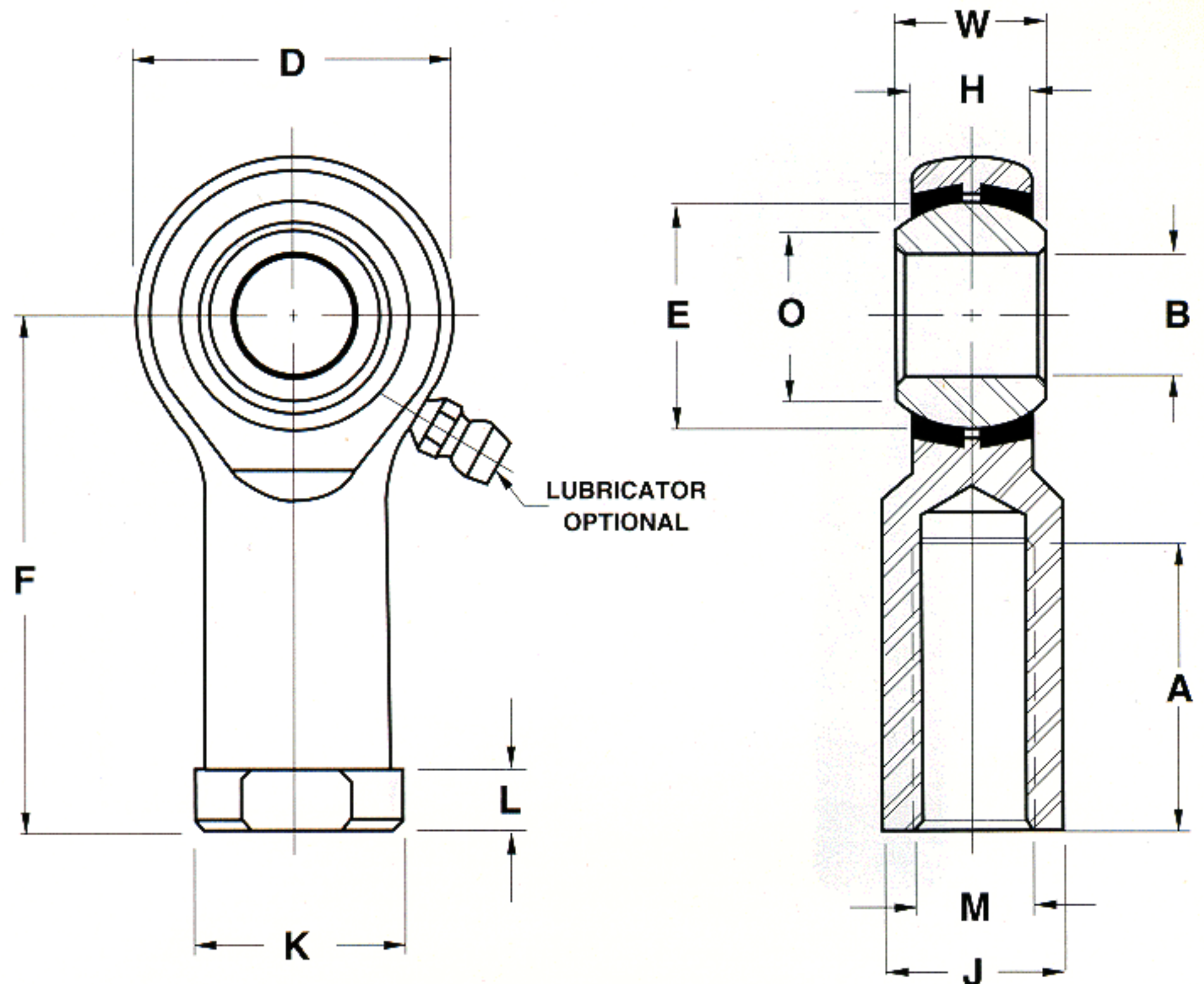

ROD ENDS

# SPHERCO®

## Commercial Extra Capacity Series Two Piece - Metal to Metal

### Series CFM

ROD END NUMBER	DIMENSIONS IN INCHES									MAXIMUM STATIC RADIAL LOAD LBF	APPROX WEIGHT LBS
	BORE	BALL WIDTH	HOUSING WIDTH	HEAD DIAMETER	LENGTH TO CENTER OF BALL	THREAD LENGTH	THREAD SIZE	BALL DIAMETER	BALL FLAT DIAMETER		
	B	W	H	D	F	A	M	E	O		
	+0.0025 -0.0005	+0.005 -0.005	+0.010 -0.010	+0.031 -0.031	+0.031 -0.031	+0.062 -0.062	UNF -3A	REF	REF		
<b>CFM3</b>	.1900	.312	.250	.625	1.250	.750	.1900 - 32	.437	.306	950	.03
<b>CFM4</b>	.2500	.375	.281	.750	1.562	1.000	.2500 - 28	.515	.353	2,000	.05
<b>CFM5</b>	.3125	.437	.344	.875	1.875	1.250	.3125 - 24	.625	.447	3,000	.08
<b>CFM6</b>	.3750	.500	.406	1.000	1.938	1.250	.3750 - 24	.718	.516	5,000	.11
<b>CFM7</b>	.4375	.562	.437	1.125	2.125	1.375	.4375 - 20	.812	.586	6,500	.16
<b>CFM8</b>	.5000	.625	.500	1.312	2.438	1.500	.5000 - 20	.937	.698	9,000	.24
<b>CFM10</b>	.6250	.750	.562	1.500	2.625	1.625	.6250 - 18	1.125	.839	10,000	.40
<b>CFM12</b>	.7500	.875	.687	1.750	2.875	1.750	.7500 - 16	1.312	.978	14,000	.63

**Outer Member:** Carbon steel, with protective coating for corrosion resistance

**Ball:** Carbon steel, case hardened, with protective coating for additional hardness and corrosion resistance

#### NOTES

- 1 Add letter "L" to prefix to indicate Left Hand thread  
Example: CFML4
- 2 For design options, see page 21
- 3 For Engineering data, see pages 18 thru 20

ROD ENDS

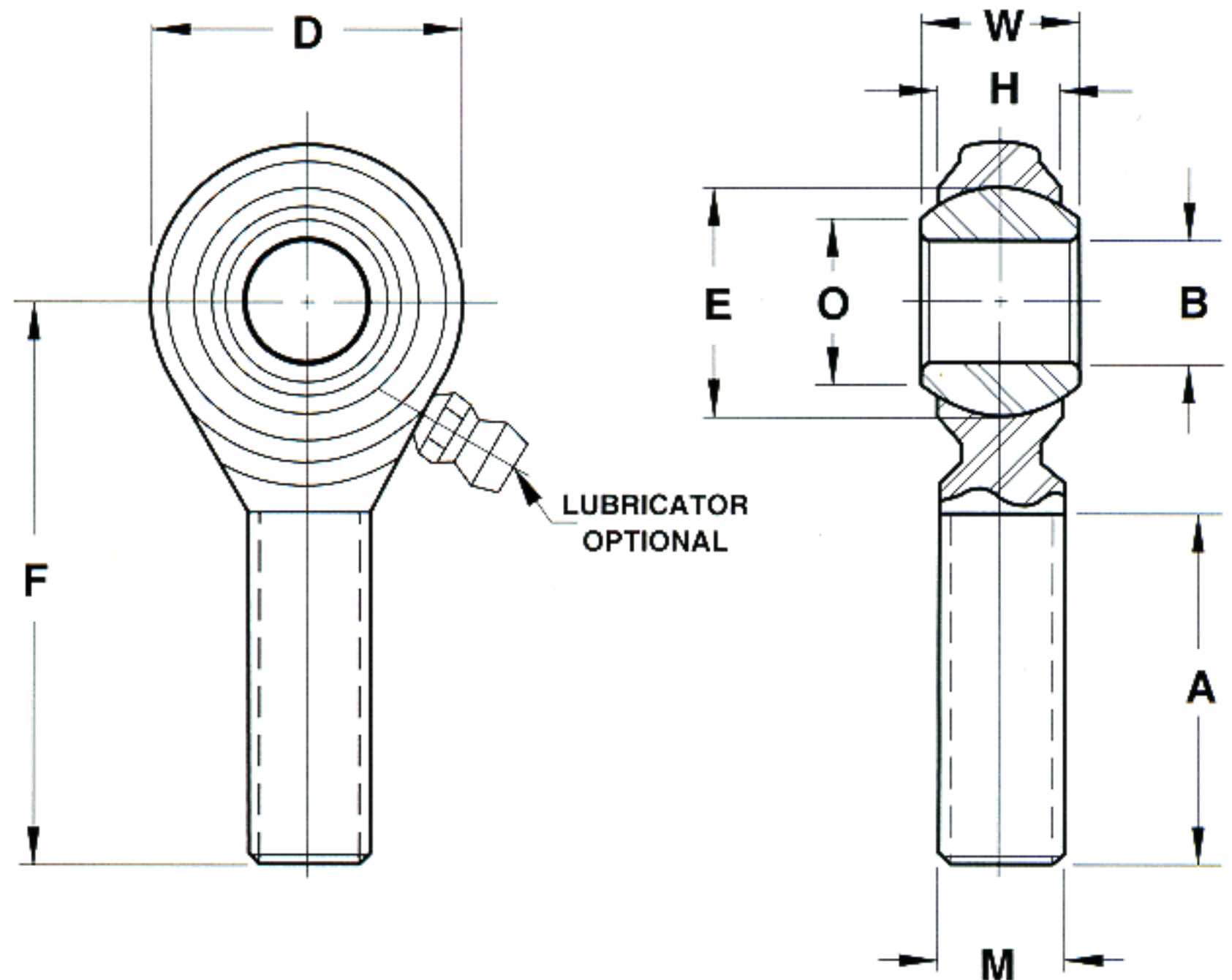

# SPHERCO®

## Commercial Extra Capacity Series

### Two Piece - Metal to Metal

#### Series CFF

ROD END NUMBER	DIMENSIONS IN INCHES											OTHER DIMENSIONS	MAXIMUM STATIC RADIAL LOAD	APPROX WEIGHT
	BORE	BALL WIDTH	HOUSING WIDTH	HEAD DIAMETER	LENGTH TO CENTER OF BALL	THREAD LENGTH	THREAD SIZE	BALL DIAMETER	BALL FLAT DIAMETER	ACROSS WRENCH FLATS				
	B	W	H	D	F	A	M	E	O	J	K			
	+0.0025 -0.0005	+0.005 -0.005	+0.010 -0.010	REF	REF	+0.062 -0.031	UNF-3B	REF	REF	REF	REF	REF	LBF	LBS
<b>CFF3</b>	.1900	.312	.250	.625	1.062	.500	.1900-32	.437	.306	.312	.406	.187	2,000	.03
<b>CFF4</b>	.2500	.375	.281	.750	1.312	.625	.2500-28	.515	.355	.375	.468	.187	3,200	.05
<b>CFF5</b>	.3125	.437	.344	.875	1.375	.625	.3125-24	.625	.447	.437	.500	.187	3,800	.08
<b>CFF6</b>	.3750	.500	.406	1.000	1.625	.687	.3750-24	.718	.517	.562	.687	.250	5,000	.12
<b>CFF7</b>	.4375	.562	.437	1.125	1.812	.812	.4375-20	.812	.586	.625	.750	.250	6,500	.17
<b>CFF8</b>	.5000	.625	.500	1.312	2.125	.937	.5000-20	.937	.698	.750	.875	.250	9,000	.26
<b>CFF10</b>	.6250	.750	.562	1.500	2.500	1.187	.6250-18	1.125	.839	.875	1.000	.312	10,000	.41
<b>CFF12</b>	.7500	.875	.687	1.750	2.875	1.375	.7500-16	1.312	.978	1.000	1.125	.312	14,000	.64

**Outer Member:** Carbon steel, with protective coating for corrosion resistance.

**Ball:** Carbon steel, case hardened, with protective coating for additional hardness and corrosion resistance.

#### NOTES

- 1 Add letter "L" to prefix to indicate Left Hand thread  
Example: CFFL4
- 2 For design options, see page 21
- 3 For Engineering data, see pages 18 thru 20

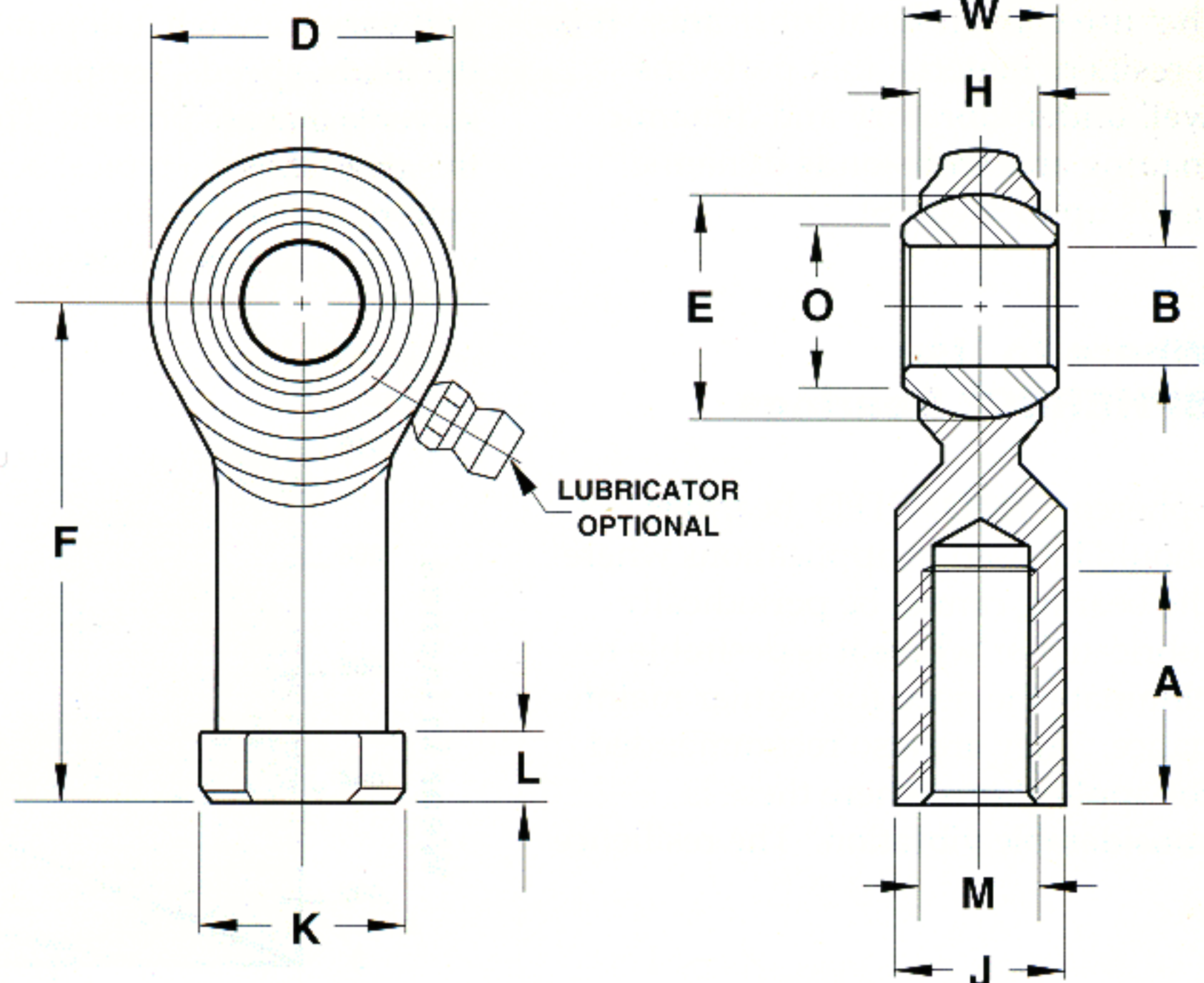

ROD ENDS

# SPHERCO®

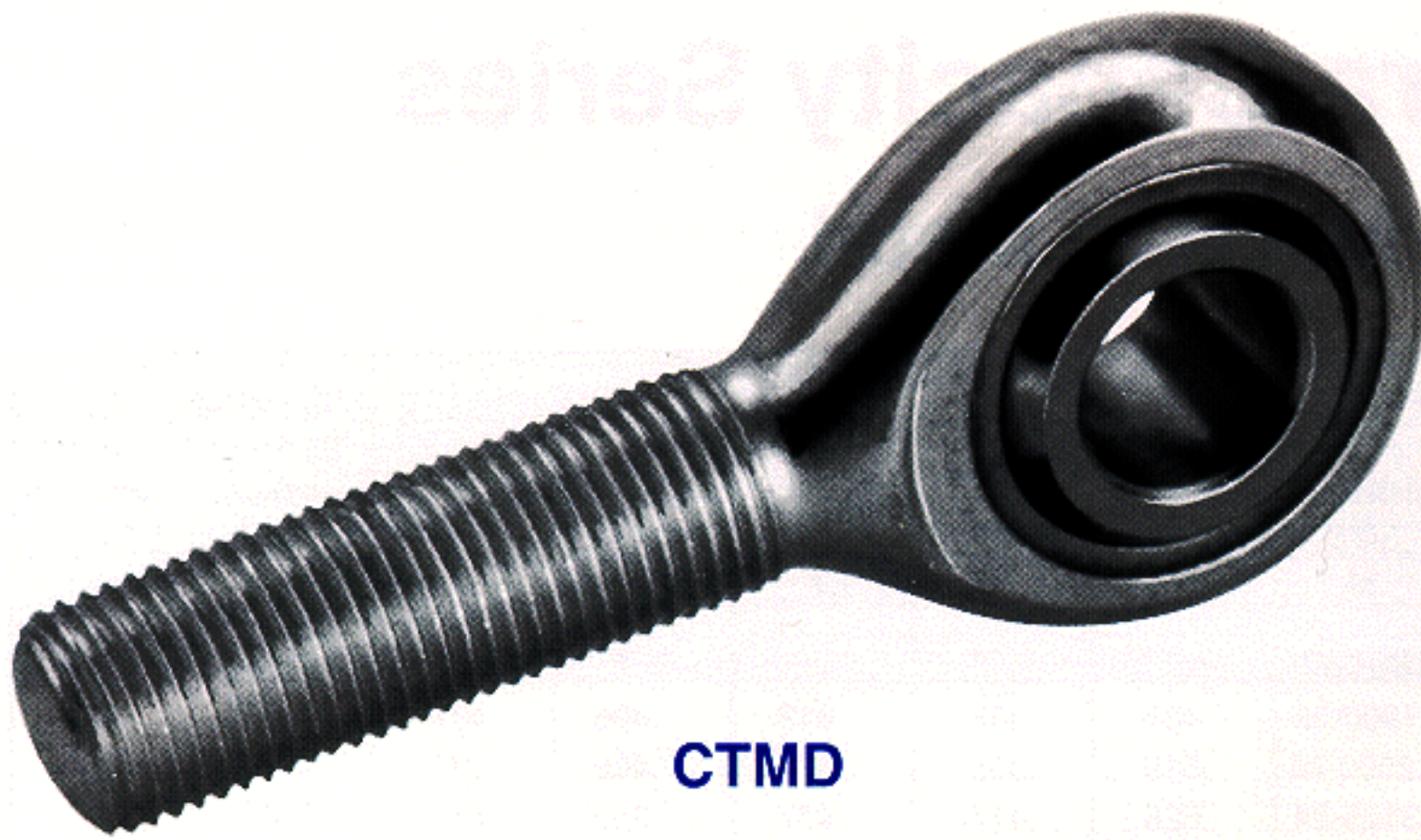

CTMD



CTFD

## SPHERCO® Self-Lubricating Series

For commercial applications where a self-lubricating bearing is either desirable or necessary, Spherco developed Spherco CTMD/CTFD Series bearings. Spherco CTMD/CTFD bearings are designed with an engineered thermoplastic race material and offer a lower coefficient of friction than metal-to-metal types that use conventional lubricants. It is a resilient material that performs well under vibratory and dynamic loading and withstands dynamic loads up to 3500 PSI.

## Where to Use SPHERCO® Bearings

Spherco CTMD/CTFD bearings should be used in applications where the bearing cannot be periodically lubricated or where it is desirable to eliminate the need for regular maintenance. They are also recommended for applications where there is considerable vibration. The resilience

of the engineered thermoplastic race absorbs vibration without causing fretting or galling of the surface. The torque level of the bearing will be low because of the low coefficient of friction of the hardened steel ball on the engineered thermoplastic race. The coefficient of friction for these bearings is approximately 0.1, but will vary somewhat depending on the loads, speeds, temperatures, and solvents that are present. The chart on this page shows a typical bearing wear pattern of these bearings and how they vary with number of oscillations.

## Environmental Characteristics

Spherco CTMD/CTFD bearings have good environmental tolerances. They offer advantages over bearings that use a nylon race because the Spherco engineered thermoplastic race absorbs very little moisture. It is generally resistant to alcohols, aldehydes, esters, ethers, hydrocarbons, weak acids and bases, water and agricultural chemicals. Dimensional stability is quite good when exposed to these substances, however the Heim engineering department should be contacted for recommendations on specific performance characteristics.

## Wear vs. Oscillations

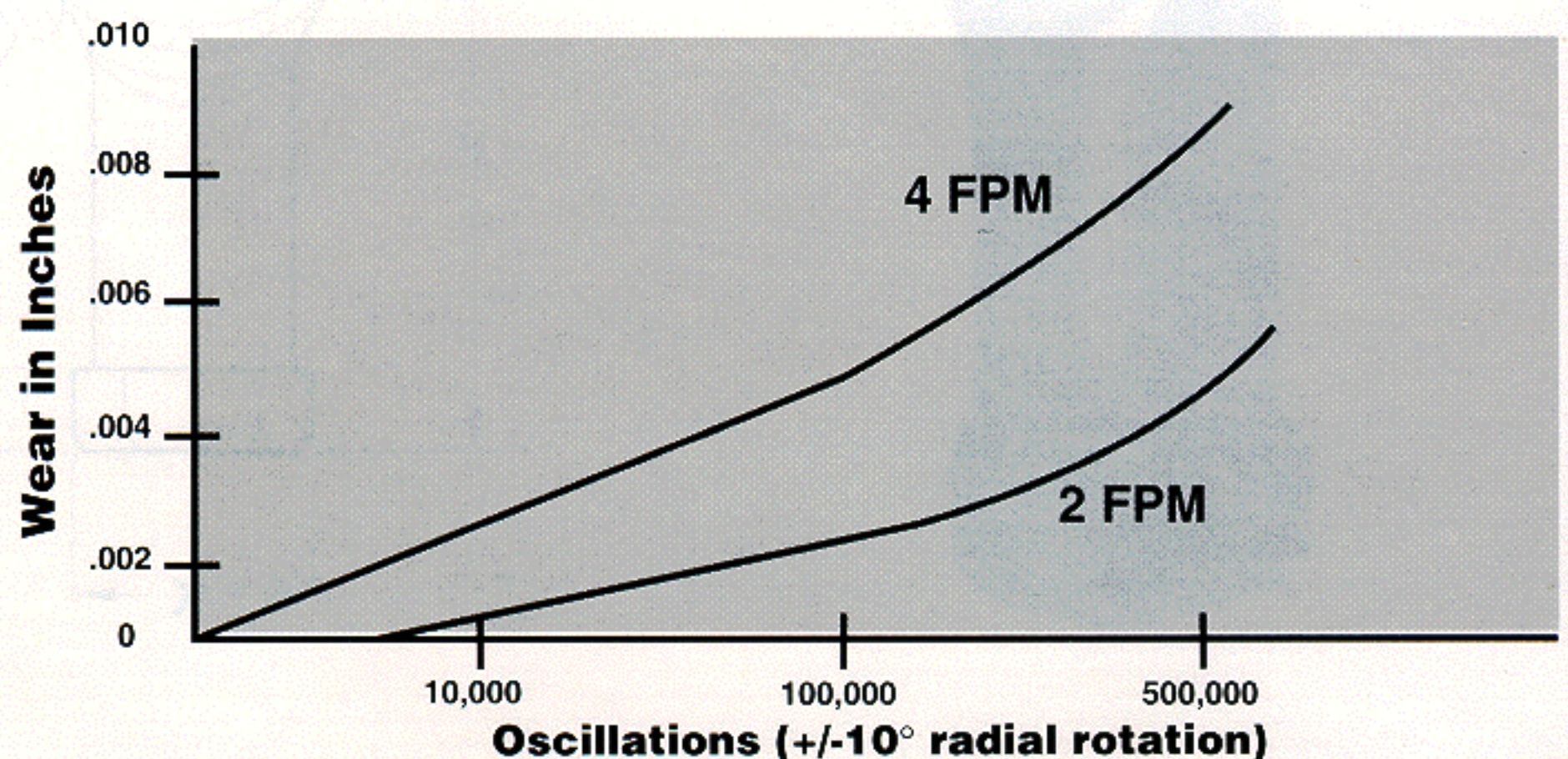

This chart shows typical wear of engineered thermoplastic race bearings (load at one-half static rating - ball surface velocity as noted),

# SPHERCO

## Commercial Series

### Light Duty - Self-Lubricating - Thermoplastic

#### Series CTMD

ROD END NUMBER	DIMENSIONS IN INCHES									MAXIMUM STATIC RADIAL LOAD	APPROX WEIGHT	
	BORE	BALL WIDTH	HOUSING WIDTH	HEAD DIAMETER	LENGTH TO CENTER OF BALL	THREAD LENGTH	THREAD SIZE	BALL DIAMETER	BALL FLAT DIAMETER			
	B	W	H	D	F	A	M	E	O			
	+0.0025 -.0005	+0.005 -.005	+0.010 -.010	REF	REF	+0.062 -.062	UNF-3A	REF	REF		LBF	LBS
CTMD3	.1900	.313	.250	.625	1.250	.750	.1900-32	.437	.306	800	.03	
CTMD4	.2500	.375	.281	.750	1.562	1.000	.2500-28	.515	.353	1,060	.05	
CTMD5	.3125	.437	.344	.875	1.875	1.250	.3125-24	.625	.447	1,575	.08	
CTMD6	.3750	.500	.406	1.000	1.938	1.250	.3750-24	.718	.516	2,150	.12	
CTMD7	.4375	.562	.437	1.125	2.125	1.375	.4375-20	.812	.586	2,600	.17	
CTMD8	.5000	.625	.500	1.312	2.438	1.500	.5000-20	.937	.698	3,425	.26	
CTMD10	.6250	.750	.562	1.500	2.625	1.625	.6250-18	1.125	.839	4,625	.41	
CTMD12	.7500	.875	.687	1.750	2.875	1.750	.7500-16	1.312	.978	6,600	.64	

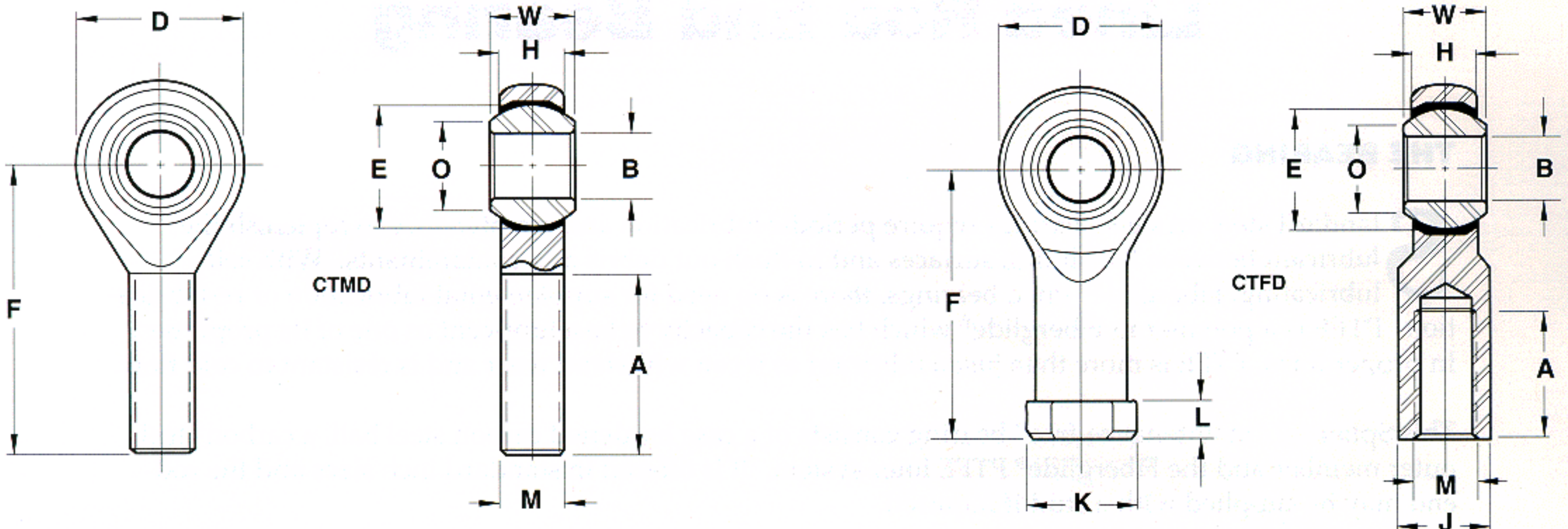

**Outer Member:** Carbon steel, with protective coating for corrosion resistance  
**Ball:** Carbon steel, case hardened, with protective coating for additional hardness and corrosion resistance  
**Race:** Engineered thermoplastic

**NOTES**  
 ① Add letter "L" to prefix to indicate Left Hand thread  
 Example: CTMDL4 or CTFDL4  
 ② For design options, see page 21  
 ③ For Engineering data, see pages 12, 18 thru 20

#### Series CTFD

ROD END NUMBER	DIMENSIONS IN INCHES											MAXIMUM STATIC RADIAL LOAD	APPROX WEIGHT	
	BORE	BALL WIDTH	HOUSING WIDTH	HEAD DIAMETER	LENGTH TO CENTER OF BALL	THREAD LENGTH	THREAD SIZE	BALL DIAMETER	BALL FLAT DIAMETER	ACROSS WRENCH FLATS	OTHER DIMENSIONS			
	B	W	H	D	F	A	M	E	O	J	K			L
	+0.0025 -.0005	+0.005 -.005	+0.010 -.010	REF	REF	+0.062 -.062	UNF-3B	REF	REF	REF	REF	REF	LBF	LBS
CTFD3	.1900	.313	.250	.625	1.062	.562	.1900 - 32	.437	.306	.312	.406	.187	800	.03
CTFD4	.2500	.375	.281	.750	1.312	.750	.2500 - 28	.515	.355	.375	.468	.187	1,060	.05
CTFD5	.3125	.437	.344	.875	1.375	.750	.3125 - 24	.625	.447	.437	.500	.187	1,575	.08
CTFD6	.3750	.500	.406	1.000	1.625	.937	.3750 - 24	.718	.517	.562	.687	.250	2,150	.12
CTFD7	.4375	.562	.437	1.125	1.812	1.062	.4375 - 20	.812	.586	.625	.750	.250	2,600	.17
CTFD8	.5000	.625	.500	1.312	2.125	1.187	.5000 - 20	.937	.698	.750	.875	.250	3,425	.26
CTFD10	.6250	.750	.562	1.500	2.500	1.500	.6250 - 18	1.125	.839	.875	1.000	.312	4,625	.41
CTFD12	.7500	.875	.687	1.750	2.875	1.750	.7500 - 16	1.312	.978	1.000	1.125	.312	6,600	.64

# FEATURED PRODUCT

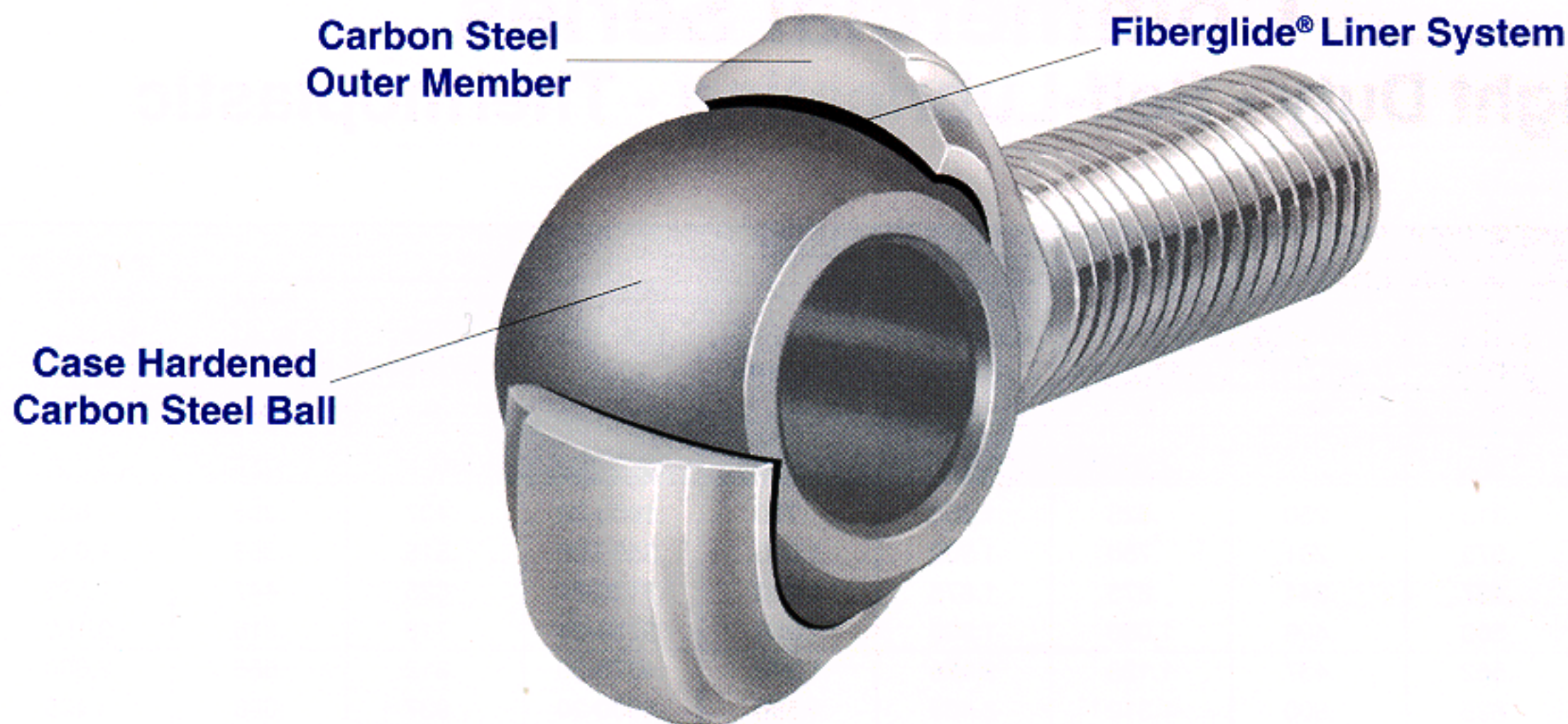

## The Spherco® Self-Lubricated, Fiberglide® Lined Rod End Bearing

### THE BEARING

Standard steel on steel bearings require periodic lubrication and maintenance to replenish the lubricant between the sliding surfaces and to flush out debris and contaminants. With self-lubricating, Fiberglide® lined bearings, there is no need for supplemental lubrication or re-lubrication. PTFE is a polymer in Fiberglide® which has the capacity to be a lubricant as one of its properties. In proper form, PTFE is more than just a lubricant as it can withstand wear and is resistant to cold flow.

This Spherco® "maintenance-free" bearing consists of a case hardened carbon steel ball, a carbon steel outer member and the Fiberglide® PTFE liner system. It is offered in standard inch sizes and the rod end may be supplied with a stud if required.

### WHAT IS FIBERGLIDE®?

Fiberglide® is the trademark used for a proprietary bearing material manufactured by RBC's Transport Dynamics Division. This material utilizes Teflon (Polytetrafluoroethylene) fibers in a woven or cloth-like form. Fiberglide® is used in many variations and may be adapted for use in broad and varied fields of applications.

Fiberglide® bearings are self-lubricating and can be run either dry or with fluids over a wide range of loads and speeds. Unlike most conventional bearings, the coefficient of friction decreases in Fiberglide® bearings as the load increases, while galling of the ball is eliminated.

Fiberglide's PTFE fibers have a tensile strength near 50,000 psi, as compared to the 4,000 to 5,000 psi for standard Teflon resin. This strength is a direct result of Fiberglide's high molecular orientation and accounts, in part, for its very high load-carrying capacity and the elimination of the usual Teflon resin cold flow problems. An equally important aspect of Fiberglide® is the superior manner in which its PTFE fibers are mechanically locked in place.



# FEATURED PRODUCT

## The Spherco® Self-Lubricated, Fiberglide® Lined Rod End Bearing

The Fiberglide® liner system is a unique PTFE fabric consisting of a special weave of PTFE Teflon® and Dacron fibers bonded to a rigid metallic backing. The weave of the fabric incorporates Dacron (B) thread bundles in one direction and a Teflon® thread (T) in the same and crossing directions. Advantages of this system versus earlier generation liner systems include:

**Low Wear** rates at **High Loads**

**High Temperature** (250°F) performance capability

**High static Strength**

**Good Resistance** to a variety of **Fluids** encountered in various applications

The Dacron fibers in the liner backing result in a matrix that is particularly resistant to breakdown caused by high vibration.

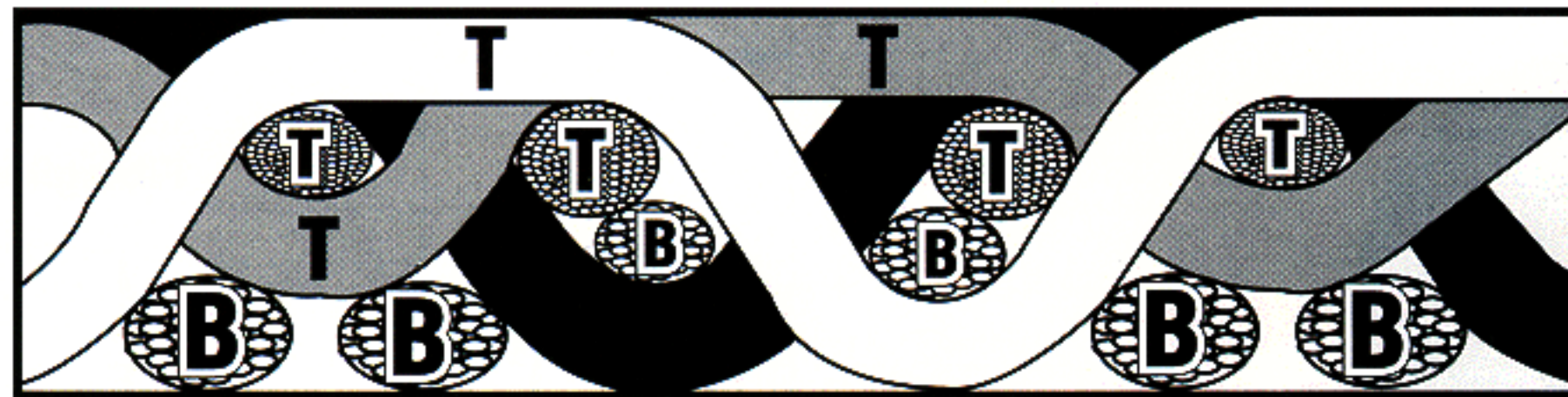

### THE SPHERCO® ADVANTAGE

Spherco Fiberglide® lined bearings have many distinct and valuable advantages over conventional metal-to-metal plain bearings. They provide the answer for many difficult applications.

Spherco Fiberglide® lined bearings:

1. Operate without lubrication while tolerating all common and many special lubricating fluids in the bearing area, as well as most non-lubricant fluids.
2. Have a low and consistent coefficient of friction.
3. Have little or no radial play.
4. Are free from stick-slip.
5. Have a high load-carrying capacity.
6. Show a high resistance to fatigue under shock.
7. Have a high resistance to wear (over 1,000,000 cycles tested).
8. Have inherent damping properties.

# SPHERCO®

## Commercial Series Extra Duty - Self-Lubricating - Fiberglide®

### Series CFM T

ROD END NUMBER	DIMENSIONS IN INCHES									MAXIMUM STATIC RADIAL LOAD	APPROX WEIGHT
	BORE	BALL WIDTH	HOUSING WIDTH	HEAD DIAMETER	LENGTH TO CENTER OF BALL	THREAD LENGTH	THREAD SIZE	BALL DIAMETER	BALL FLAT DIAMETER		
	B	W	H	D	F	A	M	E	O		
	+0.0025 -0.0005	+0.005 -0.005	+0.010 -0.010	+0.031 -0.031	+0.031 -0.031	+0.062 -0.062	UNF -2A ④	REF	REF	LBF	LBS
<b>CFM4T</b>	.2500	.375	.281	.750	1.562	1.000	.2500 - 28	.515	.353	2,000	.05
<b>CFM5T</b>	.3125	.437	.344	.875	1.875	1.250	.3125 - 24	.625	.447	3,000	.08
<b>CFM6T</b>	.3750	.500	.406	1.000	1.938	1.250	.3750 - 24	.718	.516	5,000	.11
<b>CFM8T</b>	.5000	.625	.500	1.312	2.438	1.500	.5000 - 20	.937	.698	9,000	.24
<b>CFM10T</b>	.6250	.750	.562	1.500	2.625	1.625	.6250 - 18	1.125	.839	10,000	.40
<b>CFM12T</b>	.7500	.875	.687	1.750	2.875	1.750	.7500 - 16	1.312	.978	14,000	.63

**Outer Member:** Carbon steel, with protective coating for corrosion resistance

**Ball:** Carbon steel, case hardened, with protective coating for additional hardness and corrosion resistance

**Liner:** Fiberglide®

#### NOTES

- ① Add letter "L" to prefix to indicate Left Hand thread  
Example: CFML4T
- ② For design options, see page 21
- ③ For Engineering data, see pages 18 thru 20
- ④ UNF-3A threads may be supplied at manufacturers option

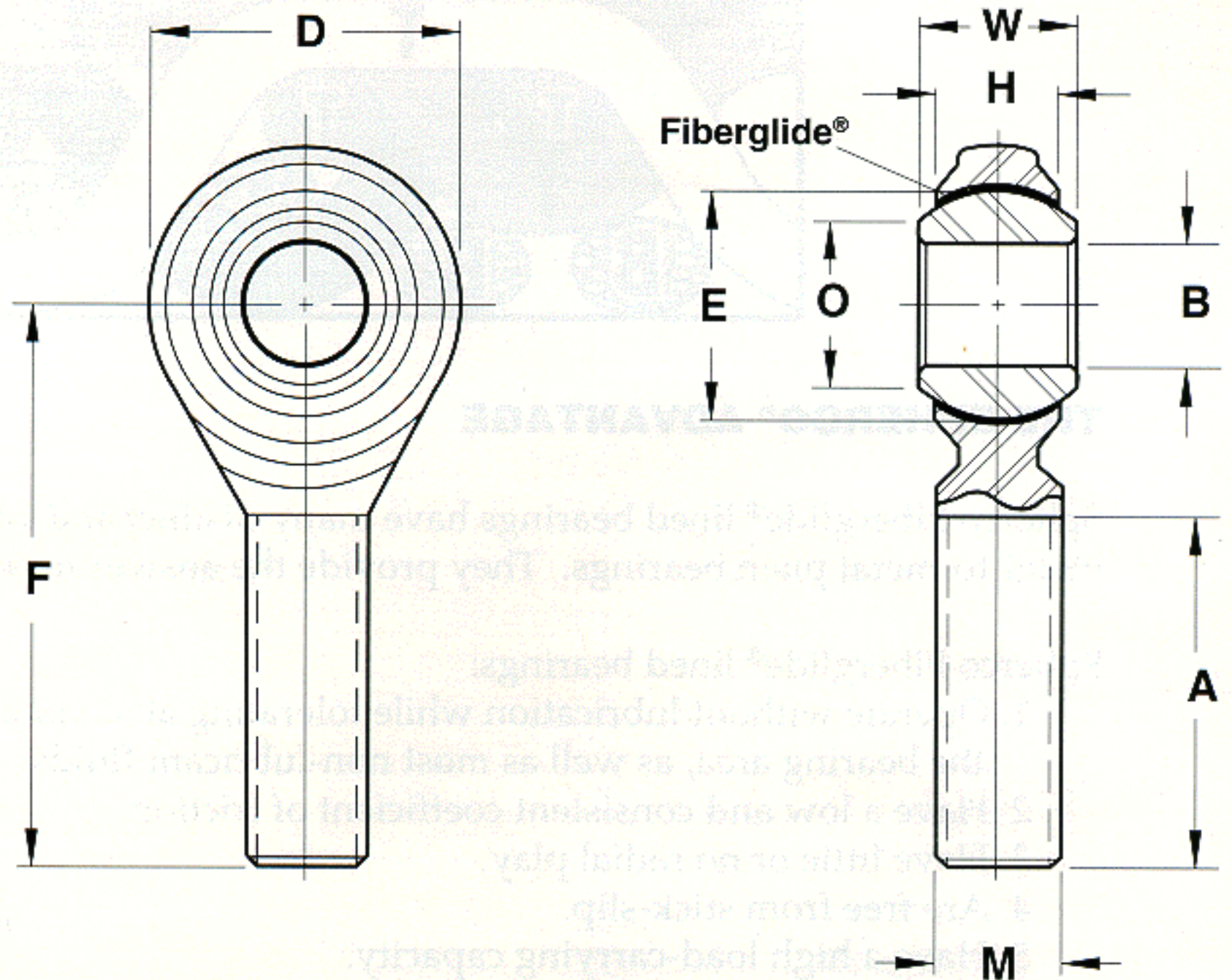

# SPHERCO®

## Commercial Series Extra Duty - Self-Lubricating - Fiberglide®

### Series CFF T

ROD END NUMBER	DIMENSIONS IN INCHES											OTHER DIMENSIONS	MAXIMUM STATIC RADIAL LOAD	APPROX WEIGHT
	BORE	BALL WIDTH	HOUSING WIDTH	HEAD DIAMETER	LENGTH TO CENTER OF BALL	THREAD LENGTH	THREAD SIZE	BALL DIAMETER	BALL FLAT DIAMETER	ACROSS WRENCH FLATS				
	B	W	H	D	F	A	M	E	O	J	K			
	+0.0025 -0.0005	+0.005 -0.005	+0.010 -0.010	REF	REF	+0.062 -0.031	UNF-2B <sup>④</sup>	REF	REF	REF	REF	REF	LBF	LBS
<b>CFF4T</b>	.2500	.375	.281	.750	1.312	.625	.2500-28	.515	.355	.375	.468	.187	3,200	.05
<b>CFF5T</b>	.3125	.437	.344	.875	1.375	.625	.3125-24	.625	.447	.437	.500	.187	3,800	.08
<b>CFF6T</b>	.3750	.500	.406	1.000	1.625	.687	.3750-24	.718	.517	.562	.687	.250	5,000	.12
<b>CFF8T</b>	.5000	.625	.500	1.312	2.125	.937	.5000-20	.937	.698	.750	.875	.250	9,000	.26
<b>CFF10T</b>	.6250	.750	.562	1.500	2.500	1.187	.6250-18	1.125	.839	.875	1.000	.312	10,000	.41
<b>CFF12T</b>	.7500	.875	.687	1.750	2.875	1.375	.7500-16	1.312	.978	1.000	1.125	.312	14,000	.64

**Outer Member:** Carbon steel, with protective coating for corrosion resistance

**Ball:** Carbon steel, case hardened, with protective coating for additional hardness and corrosion resistance

**Liner:** Fiberglide®

#### NOTES

- ① Add letter "L" to prefix to indicate Left Hand thread  
Example: CFFL4T
- ② For design options, see page 21
- ③ For Engineering data, see pages 18 thru 20
- ④ UNF-3B threads may be supplied at manufacturers option

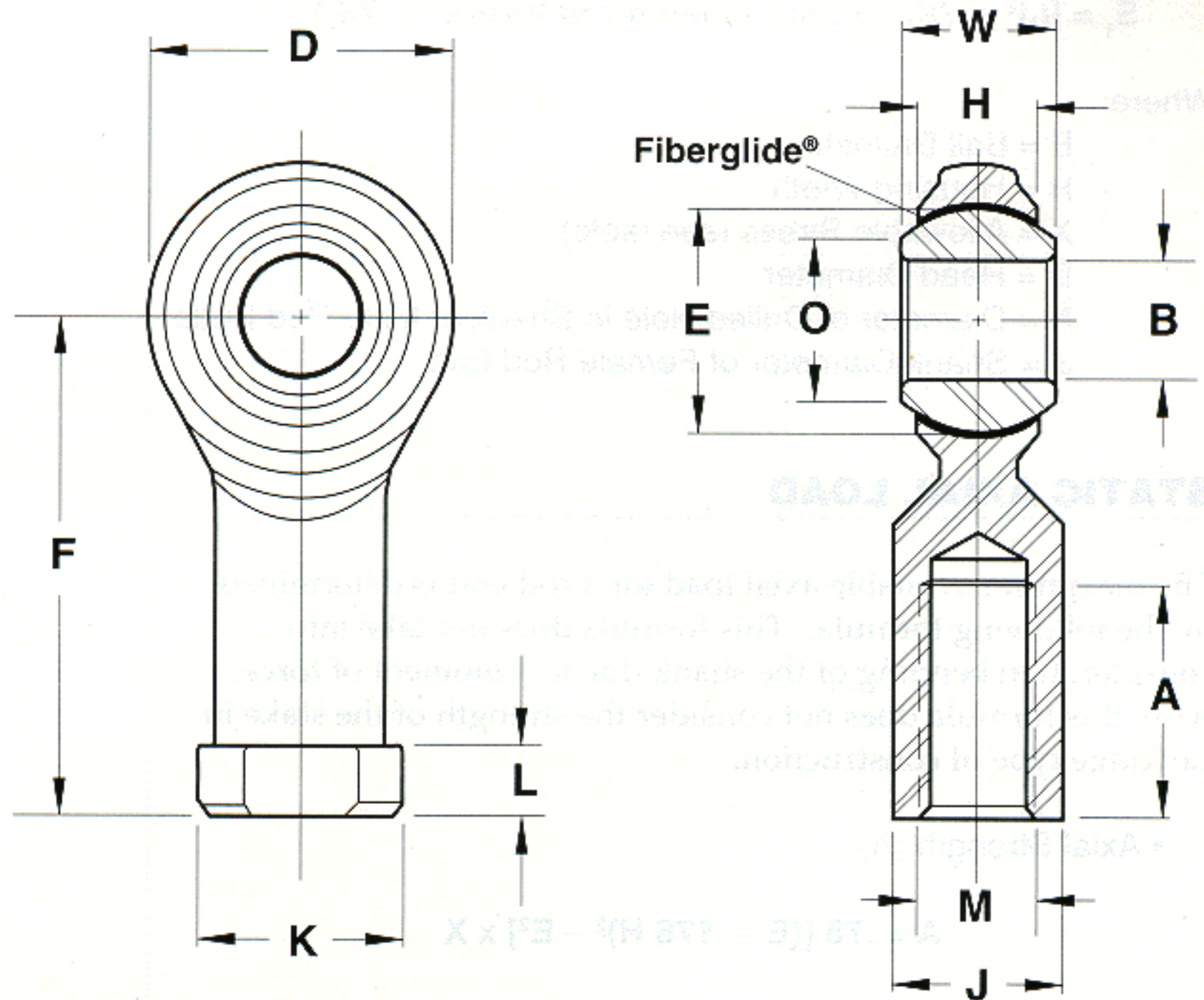

ROD ENDS

# SPHERCO

## Technical Data

### STATIC RADIAL LOAD

The maximum static radial load permissible for a rod end depends on three factors: race material compressive strength, rod end head strength, and shank strength. The maximum static radial load is determined by taking the *lowest* of the three following values:

- Race material compressive strengths (R)

$$R = E \times H \times X$$

- Rod end head strength (T)

*insert construction*

$$T = [D - (E + .176 H)] \times H \times X$$

*cartridge type construction*

$$T = \left[ \left( \frac{H}{2} \sqrt{D^2 - H^2} \right) + \left( \frac{D^2}{2} \times \sin^{-1} \frac{H}{D} \right) - (\text{O.D. of bearing} \times H) \right] \times X$$

angle of  $\frac{H}{D}$  expressed in radians

- Shank Strength (S)

*male threaded rod end*

$$S = [(\text{root diameter of thread}^2 \times .78) - (N^2 \times .78)] \times X$$

*female threaded rod end*

$$S_1 = [(J^2 \times .78) - (\text{major diameter of thread}^2 \times .78)] \times X$$

Where:

- E = Ball Diameter
- H = Housing Width
- X = Allowable Stress (see table)
- D = Head Diameter
- N = Diameter of Drilled Hole in Shank of Male Rod Ends
- J = Shank Diameter of Female Rod End

### STATIC AXIAL LOAD

The maximum available axial load for a rod end is determined by the following formula. This formula does not take into consideration bending of the shank due to a moment of force. Also, this formula does not consider the strength of the stake in cartridge type of construction.

- Axial Strength (A)

$$A = .78 [(E + .176 H)^2 - E^2] \times X$$

Where:

- X = Allowable Stress (See Table)
- E = Ball Diameter
- H = Housing Width

### MATERIAL STRESS TABLE

Material	Allowable Stress (PSI)
Brass	30,000
Aluminum Bronze	35,000
300 Series Stainless Steel	35,000
Low Carbon Steel	52,000
Alloy Steel	140,000

### MISALIGNMENT

The angle of misalignment in a rod end is controlled by the outside diameter of the head. The maximum degree of misalignment is obtained when the head contacts the side of the fork or clevis in which it is mounted.

Maximum misalignment is calculated by the following formula.

- Rod End Angle ( $\alpha$ ):

$$\alpha = \sin^{-1} \frac{W}{D} - \sin^{-1} \frac{H}{D}$$

Where:

- D = Head diameter or diameter of outer race
- H = Housing width
- W = Ball width

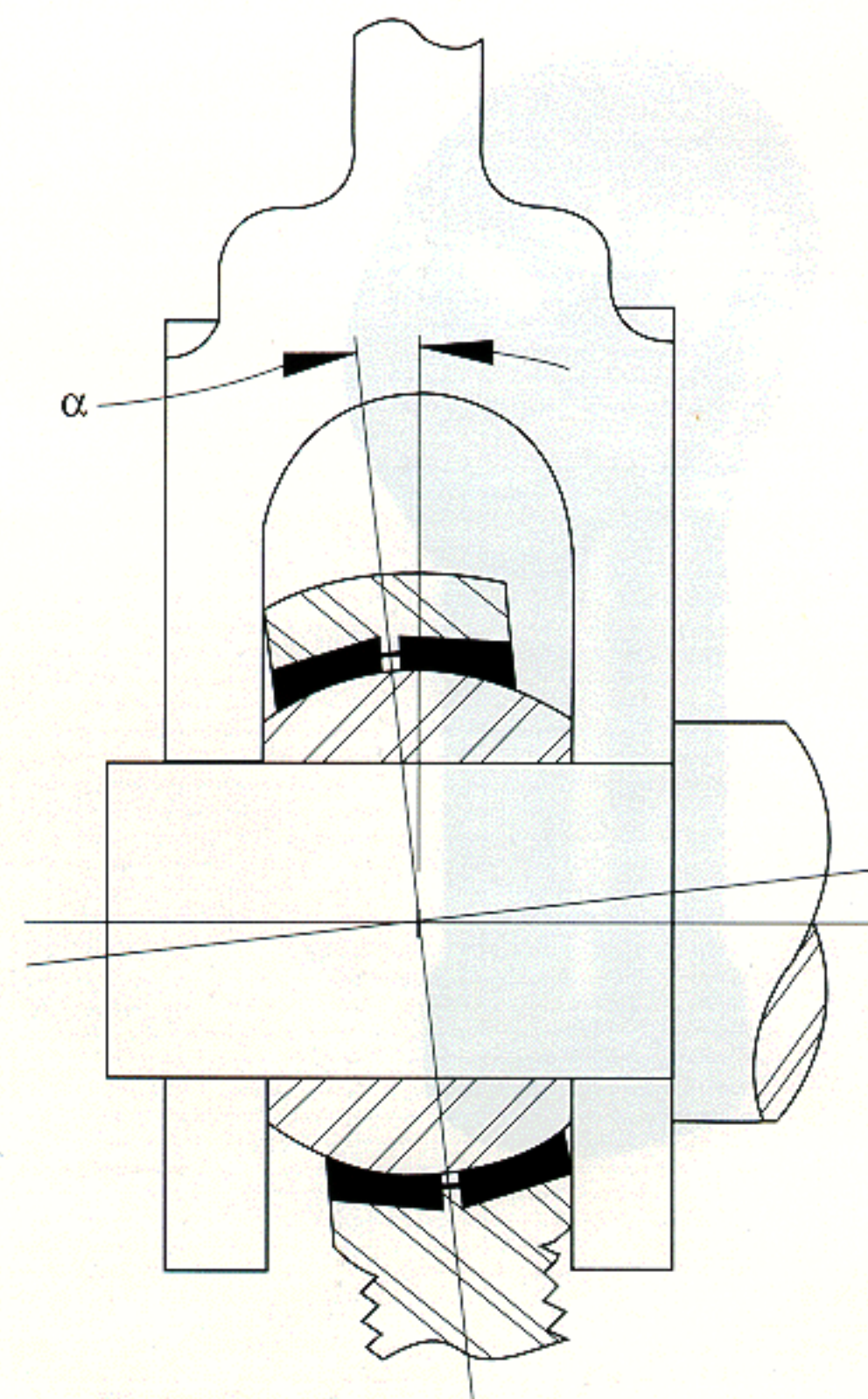

ROD ENDS

# SPHERCO

• Angles of misalignment for series:

TRE	TR	CTMD	CTFD
TM	TF	CFM	CFF
ARE 20N	AR N	ARE	CFM T
CFF T			

ROD END SIZE	MISALIGNMENT +/- DEGREES
2	8.5
2A	7.0
3	6.5
4	8.0
5	7.0
6	6.0
7	7.0
8	6.0
10	8.0
12	7.0
16	8.5

## STUDS

Studs are used in combination with Spherco rod ends to simplify mounting. Studs are compatible with the following Spherco rod end series:

CFM	CFF
TM	TF
TRE	TR
CTMD	CTFD
CFM T	CFF T

The stud is designed to accommodate up to  $\pm 25^\circ$  misalignment in any direction and has a wrench flat to facilitate tightening. Add letter "Y" to suffix to indicate stud. Example: CTMD10Y

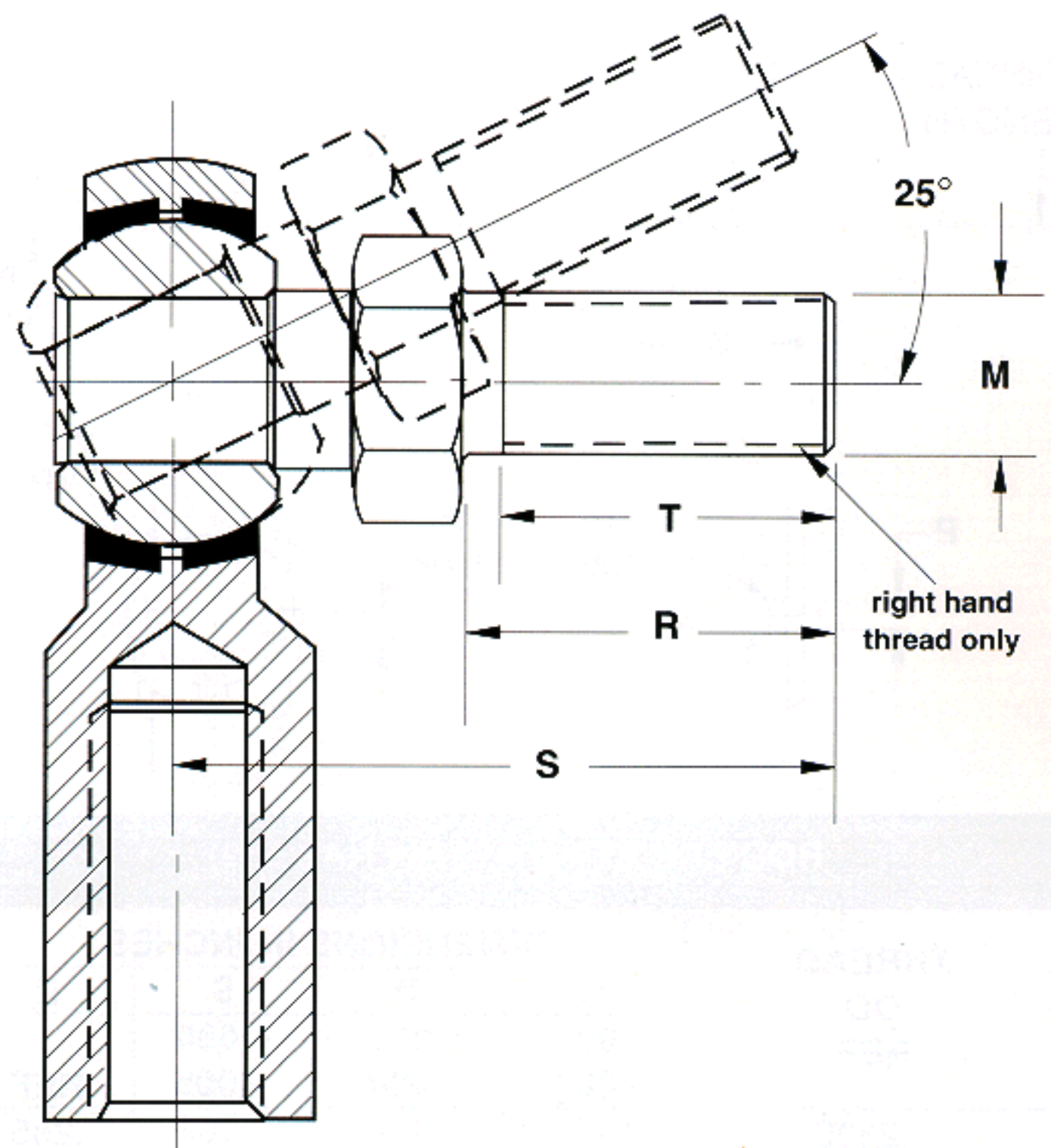

## STUD DIMENSIONS

TO FIT ROD END SIZE	DIMENSIONS IN INCHES			
	R	S	T	M
	+0.010 -0.010	+0.030 -0.030	REF	UNF-2A
3	.500	.969	.437	.1900-32
4	.562	1.047	.500	.2500-28
5	.687	1.234	.594	.3125-24
6	.906	1.540	.812	.3750-24
7	1.125	1.930	1.000	.4375-20
8	1.125	2.000	1.000	.5000-20
10	1.500	2.500	1.375	.6250-18
12	1.812	3.000	1.625	.7500-16

ROD ENDS

## KEYWAYS

Keyway slots, where available, are dimensioned as follows. Contact the Heim Engineering Department to determine keyway slot availability on a particular size.

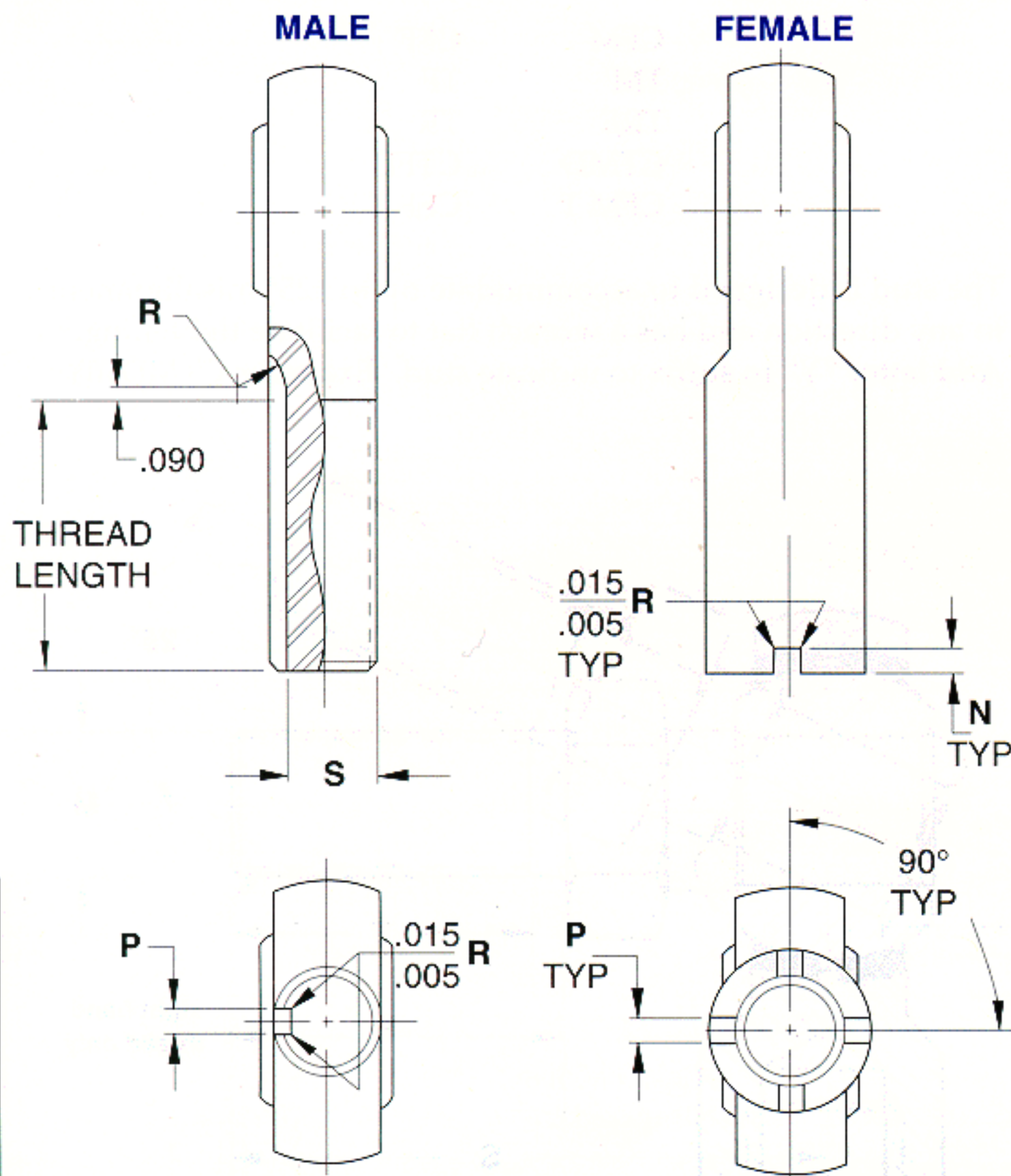

## MILITARY SPECIFICATIONS

Many of the processes used by Heim in the manufacture of rod ends are performed to U.S. Military Specifications. A partial list of these specifications follows:

PROCESS	
Anodize	MIL-A-8625 Type 1 or 2
Cadmium Plate	QQ-P-416 Type 1 Class 2
Chrome Plate	QQ-C-320 Class 2 (.0002 min)
Heat Treat	MIL-H-6875 MIL-H-7199
Magnetic Particle Inspection	ASTM-E-1444
Penetrant Inspection	ASTM-E-1417
Zinc Plate	ASTM B633 Type III, SC 1 or 2, with chromate coating

ROD END KEYWAY (Ref NAS 559)

THREAD OD REF	DIMENSIONS IN INCHES			
	N +.005 -.000	P +.005 -.000	S +.000 -.005	R REF
.2500	.056	.062	.201	.255
.3125	.056	.062	.260	.255
.3750	.056	.093	.311	.255
.4375	.069	.093	.370	.255
.5000	.069	.093	.436	.255
.5625	.077	.125	.478	.255
.6250	.077	.125	.541	.255
.7500	.077	.125	.633	.255
.8750	.086	.156	.777	.318
1.0000	.094	.156	.900	.318
1.1250	.094	.187	1.010	.382
1.2500	.116	.187	1.136	.382
1.3750	.116	.250	1.236	.445
1.5000	.116	.250	1.361	.445
1.6250	.129	.250	1.477	.445
1.7500	.129	.312	1.589	.508
1.8750	.129	.312	1.714	.508
2.0000	.129	.312	1.839	.508
2.1250	.129	.312	1.955	.508
2.2500	.129	.312	2.080	.508

ROD ENDS

## Design Options

Spherco rod end and spherical bearings can be ordered with the following design options at extra cost.

DESIGN OPTIONS	OPTION OFFERED ON THESE SERIES	ORDERING INSTRUCTIONS & PART NUMBER EXAMPLE FOR SPECIFYING DESIGN OPTIONS
Keyway/Keyslot (per NAS 559)	TRE      TR TM      TF ARE 20N    AR N ARE	add "V" to part number suffix Example: TRE8 with a keyway would be a TRE8V. (See page 20 for Keyway/Keyslot specifications)
Lubricators      -Zerk Type	TRE      TR TM      TF CFM      CFF ARE      AR	add "N" to part number suffix Example: TM6 with a zerk type lubricator would be a TM6N (available on sizes 4 through 16, male) (available on sizes 3 through 16, female)
Cross Drilled Oil Hole	SBG      SBG S SBG SS	add "A" to part number suffix Example: SBG8S would be an SBG8SA
Lubricators      -Flush type	TRE      TR TM      TF ARE 20N    AR CFM      CFF ARE	add "FN" to part number suffix Example: TM6 with a flush type lubricator would be a TM6FN (available on sizes 4 through 16 only)
Stainless Steel Inserts (300 Series)	TRE      TR TM      TF ARE 20N    AR N ARE      FSBG FLBG	add "SS" to part number suffix Example: TR6 with 300 series stainless steel inserts would be a TR6SS
Stud	TM      TF CTMD      CTFD TRE      TR CFM      CFF CFM T      CFF T	add "Y" to part number suffix Example: TM8 with a stud would be a TM8Y (See page 19 for stud specifications.)



# SPHERCO®

Spherco spherical plain bearings are intended for linkage applications where a bearing must accommodate significant misalignment. Spherical plain bearings offer flexibility in housing and mounting design. Spherco offers the industry's widest selection of spherical bearings types and sizes.

## Spherical Bearing Construction

Spherco offers two basic spherical bearing constructions. The four piece spherical bearing uses race inserts (typically of brass) to provide lubricity in the bearing area. This design offers reduced internal clearance, and provides smoother operation. It is ideal for dynamic applications. The two piece spherical bearing uses an outer race which is formed around a spherical ball. This type uses a large variety of race materials to accommodate high loads, corrosive environments, etc. and can also accommodate a PTFE liner for self-lubrication.

## Lubricating Spherical Bearings

Spherco produces both metal-to-metal and self-lubricating bearings. All metal-to-metal spherical bearings, including brass insert four piece types, require regular lubrication. This can be accomplished by splash or immersion oil lubrication, or by greasing through the housing where the spherical bearing is installed. Self-lubricating types are used where relubrication is not practical, or in applications where relubrication is not desirable (such as food processing machinery).

## Spherical Bearing Grades

These spherical bearings are offered in two grades: precision and commercial. Precision spherical bearings are manufactured to tight tolerances for applications requiring improved linkage accuracy and reduced looseness. Commercial spherical bearings are produced using standard materials and manufacturing methods and are an economical choice for industrial applications.

Precision spherical bearings series FSBG and FLBG are four piece construction which use bronze race inserts for lubricity and clearance control. They are produced to tight tolerances for applications requiring a more precise spherical bearing. Series SBG S, SBG, SBG SS and COR are two piece bearings which offer a variety of materials for the one piece race and the ball. In general, these are high strength series intended for more heavily loaded, static and dynamic applications.

Commercial spherical bearings series COM, BH LS and BTS LS are two piece spherical bearings which use steel races and balls. They are used in applications which are less demanding than those which require the precision series of spherical bearings. The BTS LS series incorporates rubber seals to protect the bearing from contamination. If you have any questions regarding the application of these spherical bearings, please contact the Heim Engineering Department.

## SPHERCO SPHERICAL BEARINGS CONSUMER GUIDE

- Best
- ⊖ Better
- Good
- ✓ Yes

	SPHERCO SERIES	LOADING				PRECISION	CORROSION RESISTANCE	SELF-LUBRICATING	MAXIMUM TEMPERATURE	SIZE RANGE	RACE MATERIAL	DESIGN
		STATIC	OSCILLATING	REVERSING	SHOCK							
PRECISION	FSBG	●	●	●	⊖	✓	⊖		250°F	1/8" to 1"	ALUMINUM BRONZE	FOUR PIECE
	FLBG	⊖	⊖	○	○	✓	⊖		250°F	3/16" to 1 7/8"	BRASS	
	SBG S	●	○	⊖	●	✓	⊖		250°F	1/8" to 1"	4130 H.T.	TWO PIECE
	SBG	●	●	●	⊖	✓	⊖		250°F	1/8" to 1"	ALUMINUM BRONZE	
	SBG SS	⊖	○	○	○	✓	●		750°F	1/8" to 1"	300 SERIES	
	COR	●	○	●	●	✓	●		750°F	3/16" to 1"	17-4 PH, H.T.	
COMMERCIAL	COM T	●	⊖	●	●		⊖	✓	250°F	3/16" to 1"	CARBON STEEL PTFE LINED	THREE PIECE
	COM	●	○	●	●		○		250°F	3/16" to 1"	CARBON STEEL	TWO PIECE
	BH LS	●	○	●	●		⊖		250°F	1" to 2"	CARBON STEEL	
	BTS LS	●	○	●	●		⊖		250°F	3/4" to 1 1/2"	CARBON STEEL	



# SPHERCO®

## SPHERICAL BEARINGS

### SPHERICAL BEARING QUICK SELECTION GUIDE

Series Size Range	Product Features	Customer Benefits	Common Applications
FSBG 1/8" to 1" FLBG 3/16" to 1 7/8"	Precision Grade, FSBG Bronze Inserts, FLBG Brass Inserts, Four Piece Construction	Low Friction Long Dynamic Life Smooth Feel Good Conformity	Packaging Equipment Textile Equipment
SBG S 1/8" to 1"	Alloy steel, heat treated, race and ball	High Loads, Shock Loads	Packaging Equipment Textile Equipment Industrial Trucks Off-the-road Equipment Hydraulic Cylinder
SBG 1/8" to 1"	Aluminum bronze race, alloy steel heat treated ball	Low Friction, Long Dynamic Life	
	Stainless steel race and ball	Corrosion Resistant	
	Stainless steel, heat treated, race and ball	Corrosion Resistant, High Loads	
COM T 3/16" to 1"	Commercial Grade Three Piece Construction, Fiberglide® Liner	High Loads, Reversing Loads, Shock Loads, Cost Effective, Self-Lubricating	Packaging Equipment Textile Equipment Robotics Hydraulic Cylinder
COM 3/16" to 1" BH LS 1" to 2" BTS LS 3/4" to 1 1/2"	Commercial Grade Two Piece Construction	High Loads, Reversing Loads, Shock Loads	Packaging Equipment Textile Equipment Industrial Trucks Off-the-road Equipment Hydraulic Cylinder



SPHERICAL

# SPHERCO®

## Precision Series Four Piece - Metal to Metal

### Series FSBG

SPHERICAL BEARING NUMBER	DIMENSIONS IN INCHES							MAXIMUM STATIC RADIAL LOAD	APPROX WEIGHT
	BORE	OUTSIDE DIAMETER	BALL WIDTH	HOUSING WIDTH	CHAMFER	BALL DIAMETER	BALL FLAT DIAMETER		
	<b>B</b>	<b>D</b>	<b>W</b>	<b>H</b> ③	<b>C</b>	<b>E</b>	<b>O</b>		
	+0.0000 -0.0005	+0.0000 -0.0005	+0.000 -0.005	+0.000 -0.005	+0.015 -0.000	REF	REF	LBF	LBS
<b>FSBG2</b>	.1650	.4687	.250	.187	.020	.343	.235	2,000	.01
<b>FSBG3</b>	.1900	.5625	.281	.218	.020	.406	.293	2,750	.02
<b>FSBG4</b>	.2500	.6562	.343	.250	.022	.500	.364	4,200	.02
<b>FSBG5</b>	.3125	.7500	.375	.281	.022	.562	.419	5,800	.03
<b>FSBG6</b>	.3750	.8125	.406	.312	.032	.625	.475	7,150	.04
<b>FSBG7</b>	.4375	.9062	.437	.343	.032	.687	.530	8,625	.05
<b>FSBG8</b>	.5000	1.0000	.500	.390	.032	.781	.600	11,200	.07
<b>FSBG9</b>	.5625	1.0937	.562	.437	.032	.875	.670	14,000	.09
<b>FSBG10</b>	.6250	1.1875	.625	.500	.032	.968	.739	17,700	.12
<b>FSBG12</b>	.7500	1.4375	.750	.593	.044	1.187	.920	25,750	.21
<b>FSBG14</b>	.8750	1.5625	.875	.703	.044	1.312	.980	33,600	.27
<b>FSBG16</b>	1.0000	1.7500	1.000	.797	.044	1.500	1.118	37,520	.38

**Outer Member:** 4130 or 4340 Alloy steel, heat treated, with protective coating for corrosion resistance on all surfaces exposed after installation

**Ball:** 52100 Alloy steel, heat treated, chrome plated

**Inserts:** Copper alloy

#### NOTES

- 1 For design options, see page 21
- 2 For Engineering data, see pages 32 and 33
- 3 "H" tolerance across inserts is +/-0.015

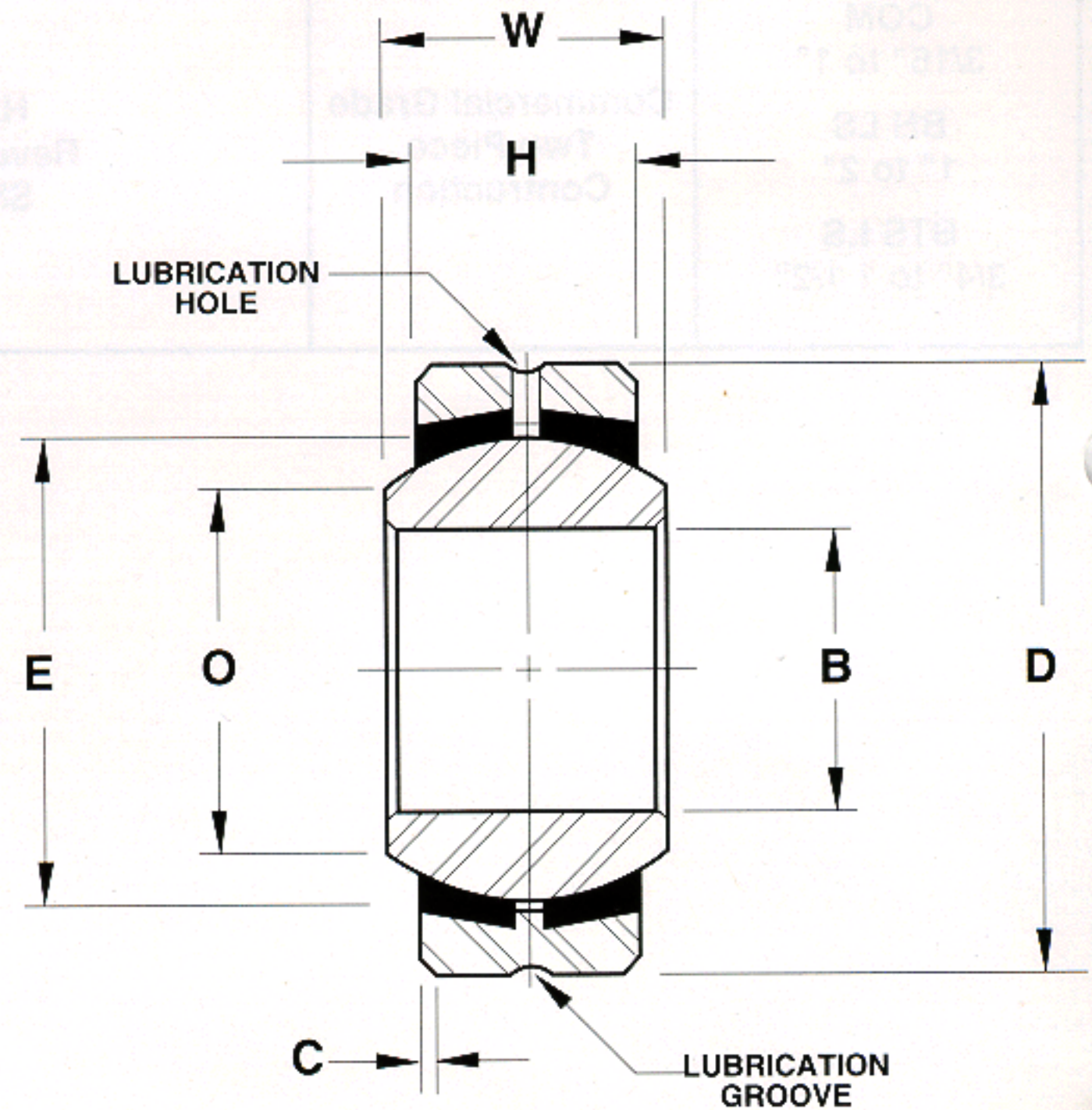

SPHERICAL

# SPHERCO®

## Precision Extra Capacity Series Four Piece - Metal to Metal

### Series FLBG

SPHERICAL BEARING NUMBER	DIMENSIONS IN INCHES							MAXIMUM STATIC RADIAL LOAD LBF	APPROX WEIGHT LBS
	BORE	OUTSIDE DIAMETER	BALL WIDTH	HOUSING WIDTH	CHAMFER	BALL DIAMETER	BALL FLAT DIAMETER		
	B	D	W	H ③	C	E	O		
	+ .0000 - .0005	+ .0000 - .0005	+ .000 - .005	+ .000 - .005	+ .015 - .000	REF	REF		
<b>FLBG3</b>	.1900	.6250	.281	.187	.016	.406	.293	2,960	.02
<b>FLBG4</b>	.2500	.7500	.375	.281	.016	.515	.354	5,245	.04
<b>FLBG5</b>	.3125	.8750	.437	.313	.016	.625	.447	6,550	.05
<b>FLBG6</b>	.3750	1.0000	.500	.375	.016	.718	.517	8,605	.08
<b>FLBG7</b>	.4375	1.1875	.562	.437	.032	.812	.586	11,100	.12
<b>FLBG8</b>	.5000	1.3125	.687	.531	.044	.937	.637	15,600	.18
<b>FLBG10</b>	.6250	1.5625	.875	.687	.044	1.187	.802	25,700	.33
<b>FLBG12</b>	.7500	2.2500	1.250	.937	.044	1.625	1.038	47,600	.97
<b>FLBG16</b>	1.0000	2.3750	1.125	.875	.062	1.750	1.345	48,200	.94
<b>FLBG19</b>	1.1875	2.6250	1.250	1.000	.085	2.000	1.562	63,000	1.27
<b>FLBG24</b>	1.5000	3.2500	1.500	1.250	.085	2.500	2.000	98,000	2.38
<b>FLBG30</b>	1.8750	4.0000	1.625	1.313	.125	3.000	2.521	123,500	3.75

**Outer Member:** Carbon steel, with protective coating for corrosion resistance on all surfaces exposed after installation

**Ball:** 52100 Alloy steel, heat treated, chrome plated

**Inserts:** Brass

#### NOTES

- ① For design options, see page 21
- ② For Engineering data, see pages 32 and 33
- ③ "H" tolerance across inserts is +/- .015

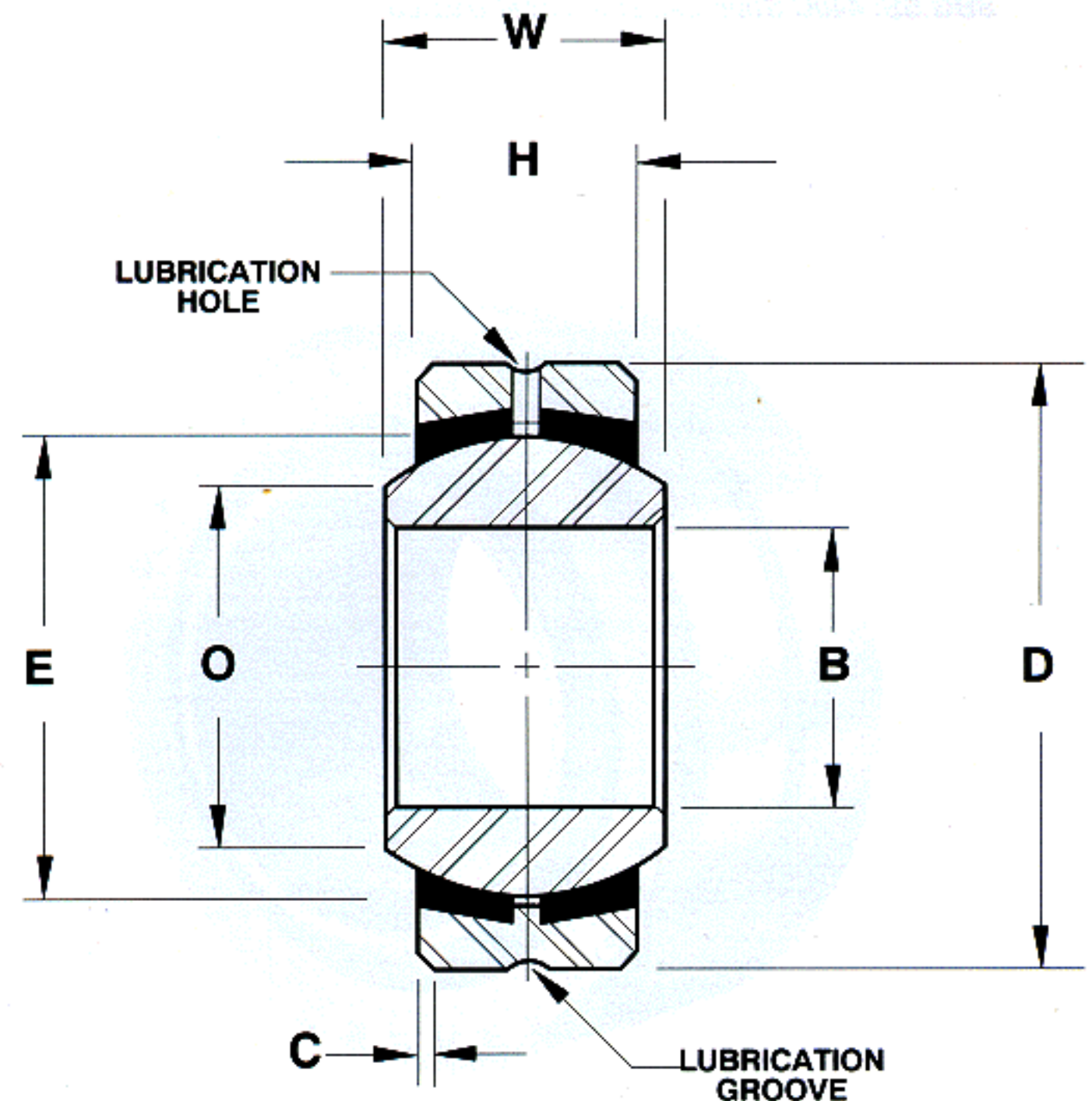
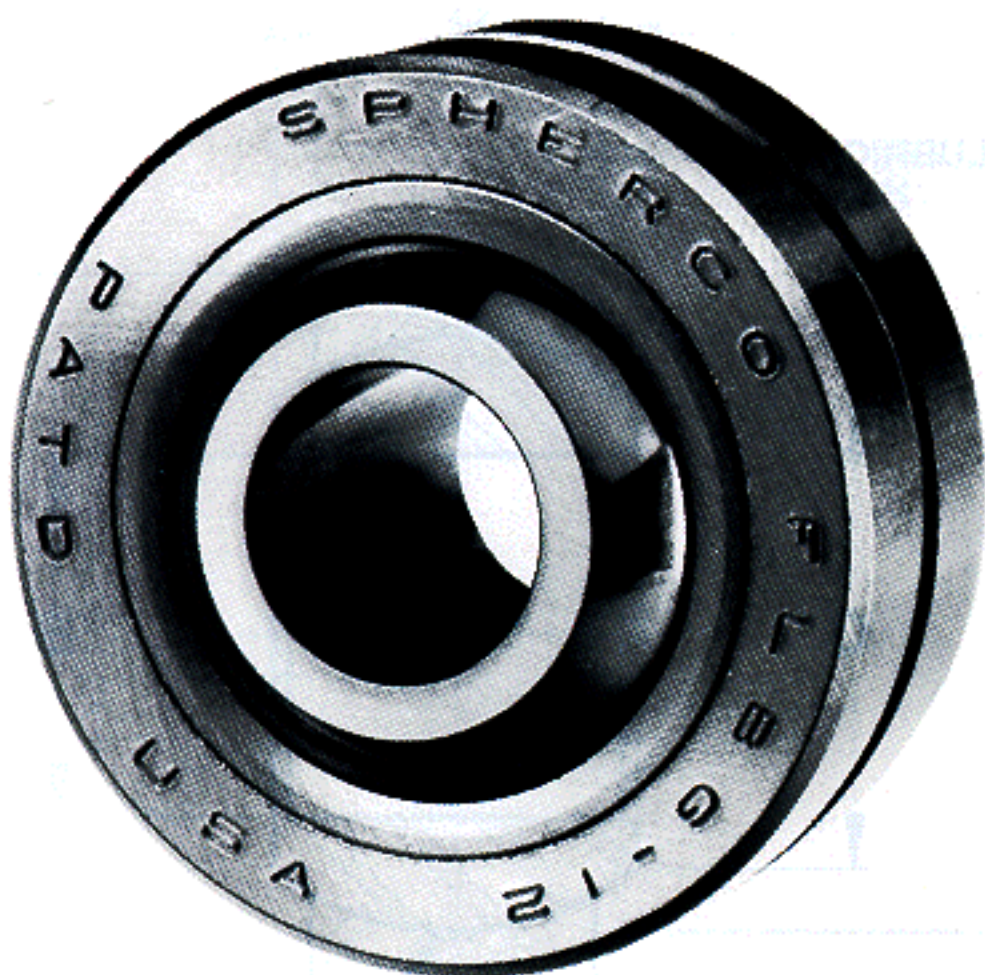

SPHERICAL

# SPHERCO

## Precision Series Two Piece - Metal to Metal

### Series SBG S, SBG, SBG SS

SPHERICAL BEARING NUMBER			DIMENSIONS IN INCHES							MAXIMUM STATIC RADIAL LOAD			APPROX WEIGHT
			BORE	OUTSIDE DIAMETER	BALL WIDTH	HOUSING WIDTH	CHAMFER	BALL DIAMETER	BALL FLAT DIAMETER	LBF			
			B	D	W	H	C	E	O	SBG S SERIES	SBG SERIES	SBG SS SERIES	LBS
			+0.0000 -0.0005	+0.0000 -0.0005	+0.000 -0.005	+0.005 -0.005	+0.015 -0.000	REF	REF				
<b>SBG2S</b>	<b>SBG2</b>	<b>SBG2SS</b>	.1650	.4687	.250	.187	.020	.343	.235	4,400	2,000	3,200	.01
<b>SBG3S</b>	<b>SBG3</b>	<b>SBG3SS</b>	.1900	.5625	.281	.218	.020	.406	.293	6,480	2,750	4,400	.02
<b>SBG4S</b>	<b>SBG4</b>	<b>SBG4SS</b>	.2500	.6562	.343	.250	.022	.500	.364	10,000	4,200	6,700	.02
<b>SBG5S</b>	<b>SBG5</b>	<b>SBG5SS</b>	.3125	.7500	.375	.281	.022	.562	.419	13,900	5,800	9,200	.03
<b>SBG6S</b>	<b>SBG6</b>	<b>SBG6SS</b>	.3750	.8125	.406	.312	.032	.625	.475	18,750	7,750	12,400	.04
<b>SBG7S</b>	<b>SBG7</b>	<b>SBG7SS</b>	.4375	.9062	.437	.343	.032	.687	.530	22,300	9,300	14,900	.05
<b>SBG8S</b>	<b>SBG8</b>	<b>SBG8SS</b>	.5000	1.0000	.500	.390	.032	.781	.600	26,900	11,200	17,900	.07
<b>SBG9S</b>	<b>SBG9</b>	<b>SBG9SS</b>	.5625	1.0937	.562	.437	.032	.875	.670	36,000	14,800	23,700	.09
<b>SBG10S</b>	<b>SBG10</b>	<b>SBG10SS</b>	.6250	1.1875	.625	.500	.032	.968	.739	48,000	20,000	32,000	.12
<b>SBG12S</b>	<b>SBG12</b>	<b>SBG12SS</b>	.7500	1.4375	.750	.593	.044	1.187	.920	78,000	30,000	48,000	.21
<b>SBG14S</b>	<b>SBG14</b>	<b>SBG14SS</b>	.8750	1.5625	.875	.703	.044	1.312	.980	103,000	43,000	69,000	.27
<b>SBG16S</b>	<b>SBG16</b>	<b>SBG16SS</b>	1.0000	1.7500	1.000	.797	.044	1.500	1.118	125,000	52,000	83,000	.38

**Outer Member:** SBG S: 4130 or 4340 Alloy steel, heat treated, with protective coating for corrosion resistance on all surfaces exposed after installation  
 SBG: Aluminum bronze  
 SBG SS: 300 Series stainless steel

**Ball:** SBG S: 52100 Alloy steel, heat treated, chrome plated  
 SBG: 52100 Alloy steel, heat treated, chrome plated  
 SBG SS: 440C Stainless steel, heat treated

#### NOTES

- For design options, see page 21
- For Engineering data, see pages 32 and 33

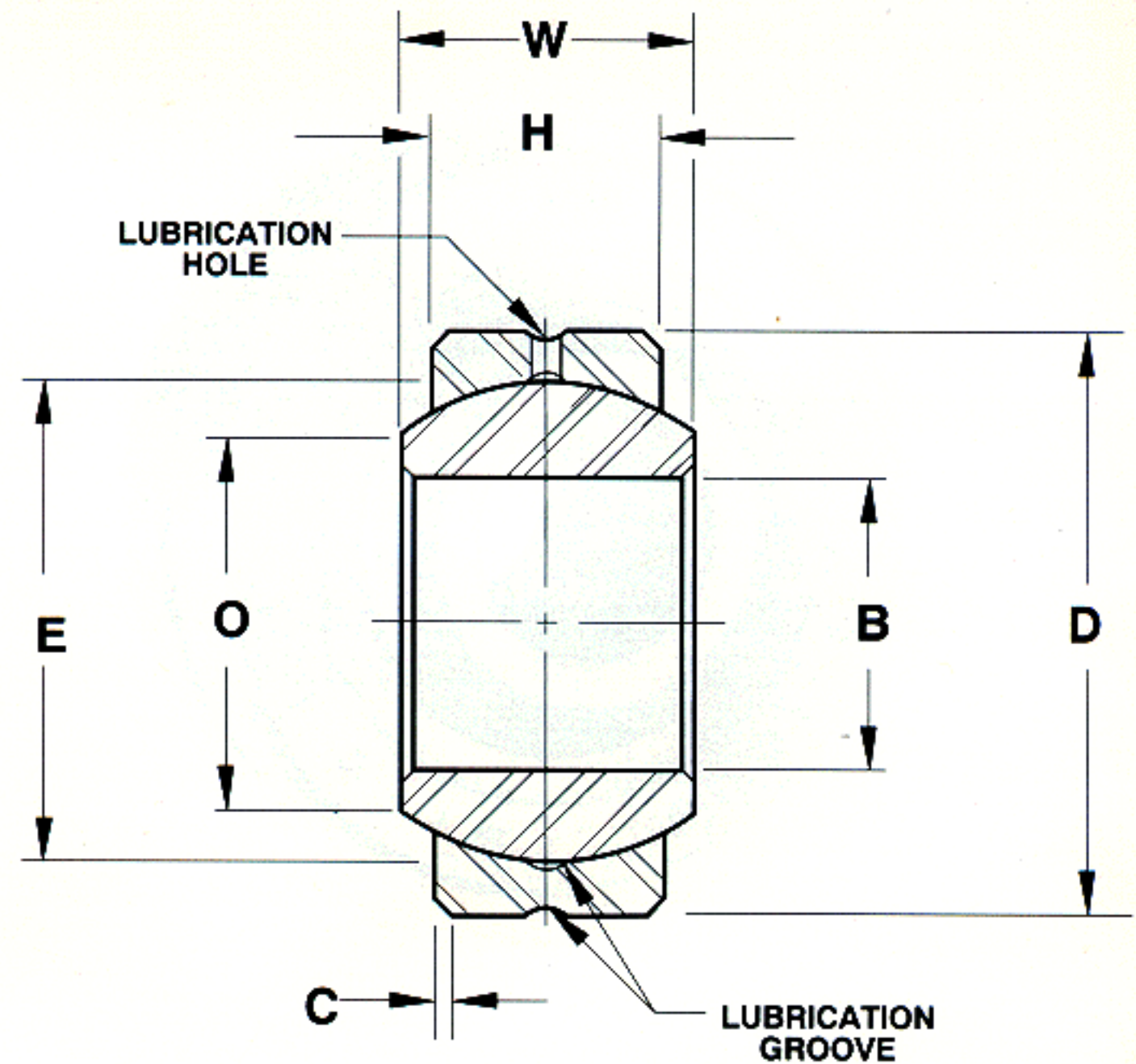

SPHERICAL



# SPHERCO®

## Precision Series Two Piece - Corrosion Resistant - Metal to Metal

### Series COR

SPHERICAL BEARING NUMBER	DIMENSIONS IN INCHES							MAXIMUM STATIC RADIAL LOAD LBF
	BORE B	OUTSIDE DIAMETER D	BALL WIDTH W	HOUSING WIDTH H	CHAMFER C	BALL DIAMETER E	BALL FLAT DIAMETER O	
	+ .0000 - .0005	+ .0000 - .0005	+ .000 - .005	+ .005 - .005	+ .015 - .000	REF	REF	
<b>COR3</b>	.1900	.5625	.281	.218	.020	.406	.293	4,800
<b>COR4</b>	.2500	.6562	.343	.250	.022	.500	.364	7,500
<b>COR5</b>	.3125	.7500	.375	.281	.022	.562	.419	10,400
<b>COR6</b>	.3750	.8125	.406	.312	.032	.625	.475	14,000
<b>COR7</b>	.4375	.9062	.437	.343	.032	.687	.530	16,750
<b>COR8</b>	.5000	1.0000	.500	.390	.032	.781	.600	20,000
<b>COR9</b>	.5625	1.0937	.562	.437	.032	.875	.670	27,000
<b>COR10</b>	.6250	1.1875	.625	.500	.032	.968	.739	36,000
<b>COR12</b>	.7500	1.4375	.750	.593	.044	1.187	.920	54,000
<b>COR14</b>	.8750	1.5625	.875	.703	.044	1.312	.980	77,000
<b>COR16</b>	1.0000	1.7500	1.000	.797	.044	1.500	1.118	93,500

**Outer Member:** 17-4 PH Stainless steel, heat treated

**Ball:** 440C Stainless steel, heat treated, chrome plated

#### NOTES

- For design options, see page 21
- For Engineering data, see pages 32 and 33

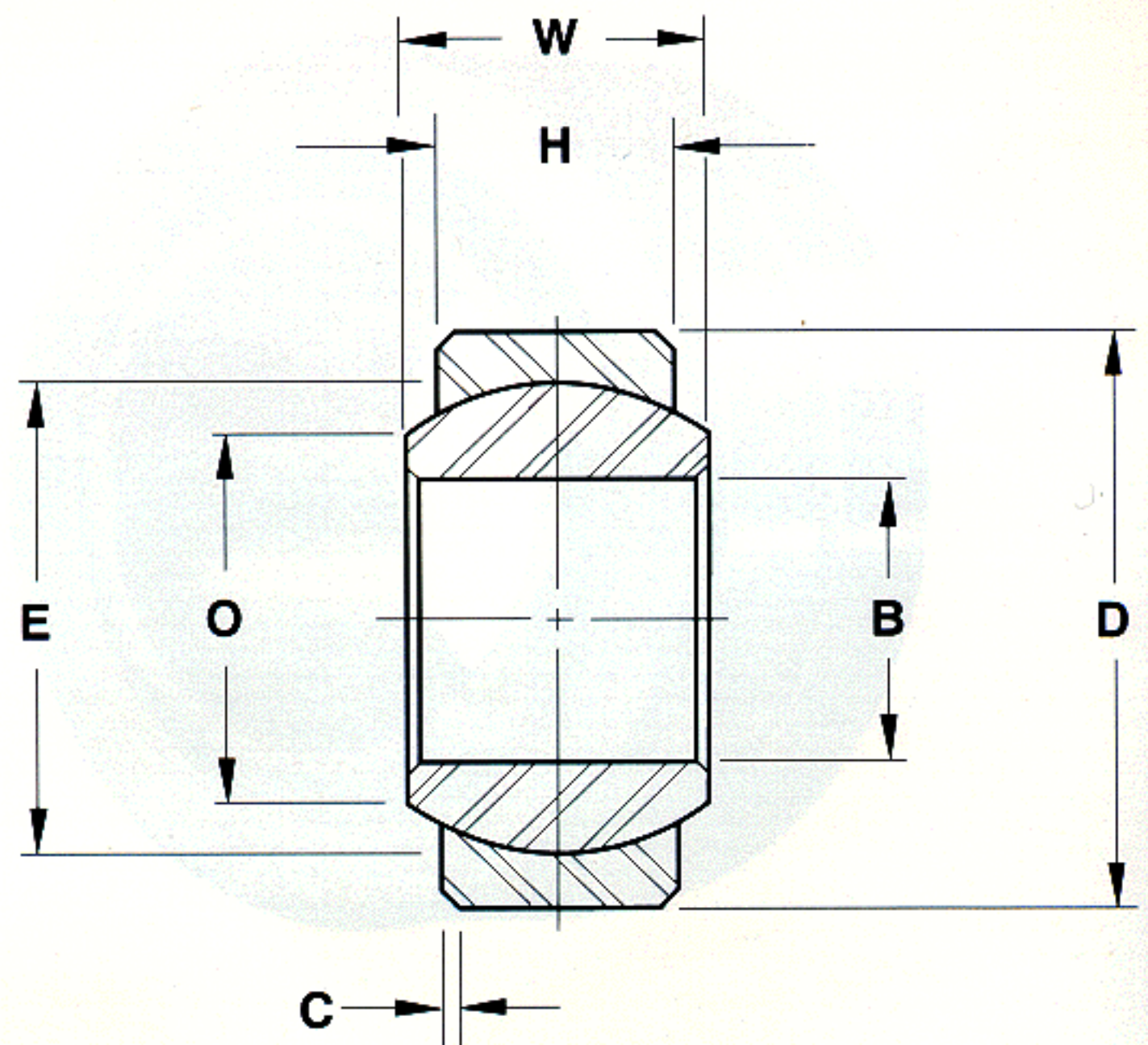
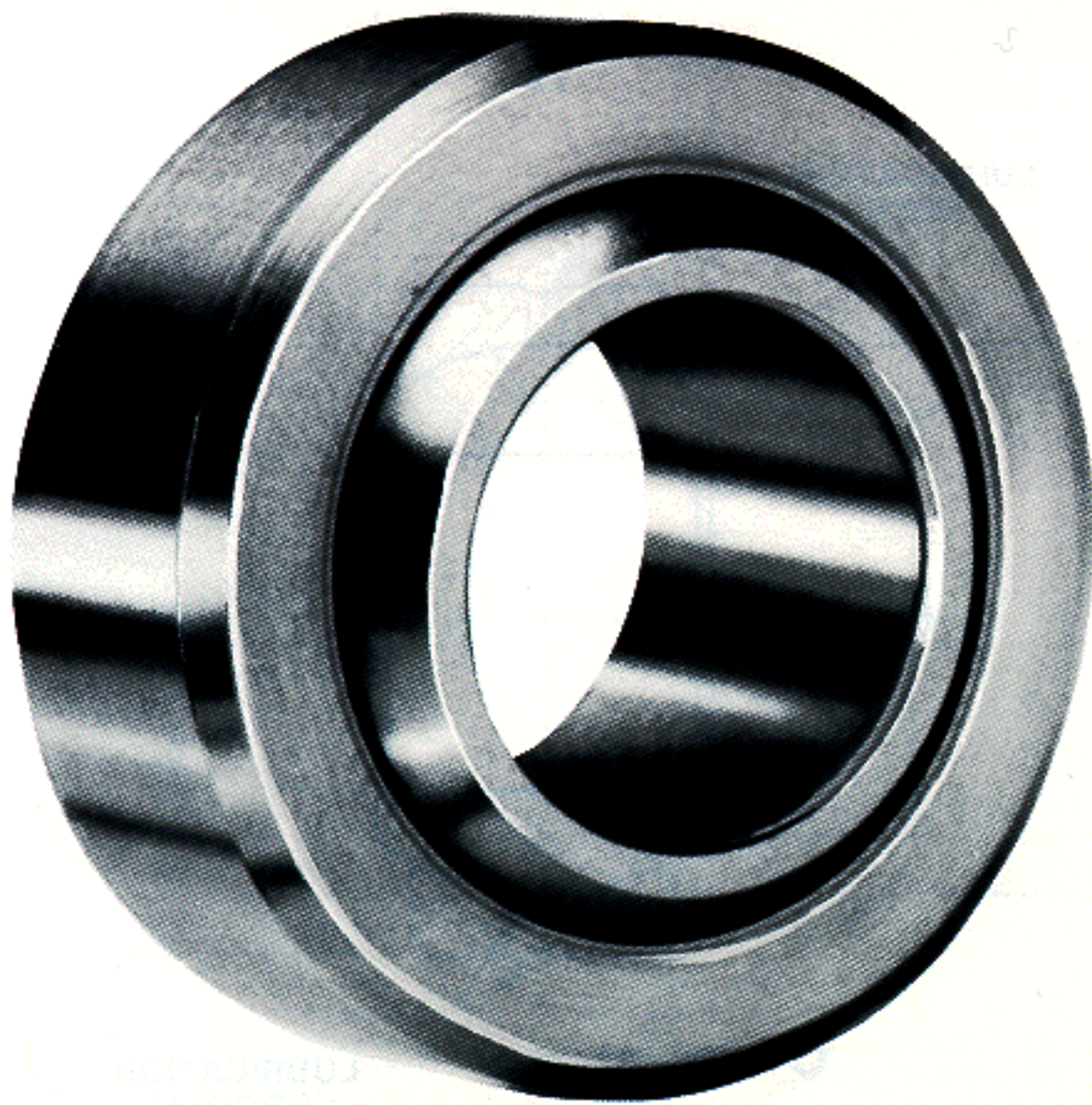

SPHERICAL BEARINGS

# SPHERCO®

## Commercial Series Two Piece - Metal to Metal

### Series COM

SPHERICAL BEARING NUMBER	DIMENSIONS IN INCHES							MAXIMUM STATIC RADIAL LOAD LBF	APPROX WEIGHT LBS
	BORE	OUTSIDE DIAMETER	BALL WIDTH	HOUSING WIDTH	CHAMFER	BALL DIAMETER	BALL FLAT DIAMETER		
	B	D	W	H	C	E	O		
	+0.0015 -0.0005	+0.0000 -0.0007	+0.005 -0.005	+0.010 -0.010	+0.015 -0.000	REF	REF		
COM3	.1900	.5625	.281	.218	.020	.406	.293	3,250	.02
COM4	.2500	.6562	.343	.250	.022	.500	.364	4,900	.02
COM5	.3125	.7500	.375	.281	.032	.562	.419	6,450	.03
COM6	.3750	.8125	.406	.312	.032	.625	.475	8,250	.04
COM7	.4375	.9062	.437	.343	.032	.687	.530	10,200	.05
COM8	.5000	1.0000	.500	.390	.032	.781	.600	13,600	.07
COM9	.5625	1.0937	.562	.437	.032	.875	.670	15,900	.09
COM10	.6250	1.1875	.625	.500	.032	.968	.739	21,000	.12
COM12	.7500	1.4375	.750	.593	.044	1.187	.920	30,000	.21
COM14	.8750	1.5625	.875	.703	.044	1.312	.980	41,100	.27
COM16	1.0000	1.7500	1.000	.797	.044	1.500	1.118	54,700	.38

**Outer Member:** Carbon steel, with protective coating for corrosion resistance on all surfaces exposed after installation

**Ball:** 52100 Alloy steel, heat treated, chrome plated

#### NOTES

- ① For design options, see page 21
- ② For Engineering data, see pages 32 and 33

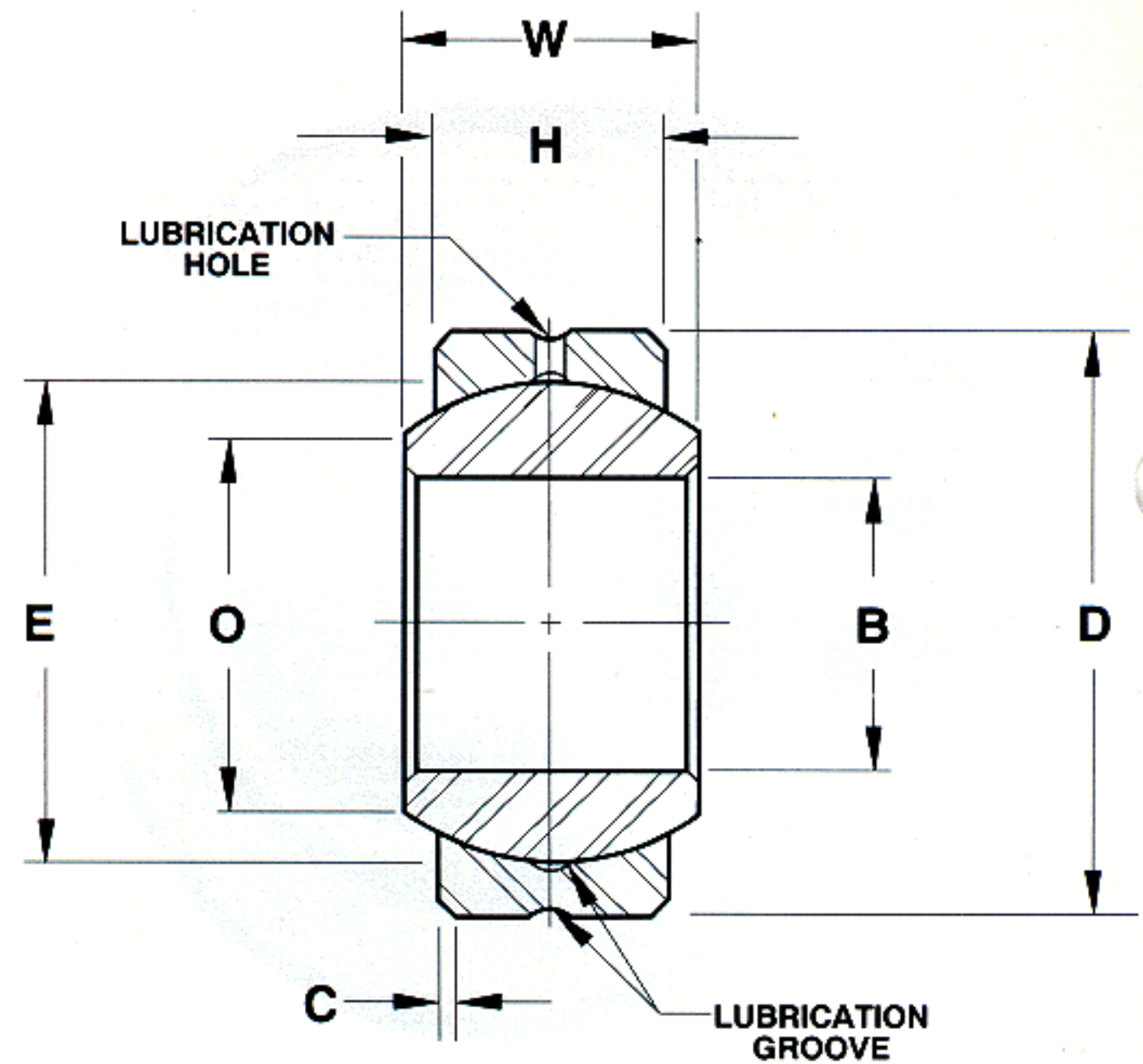
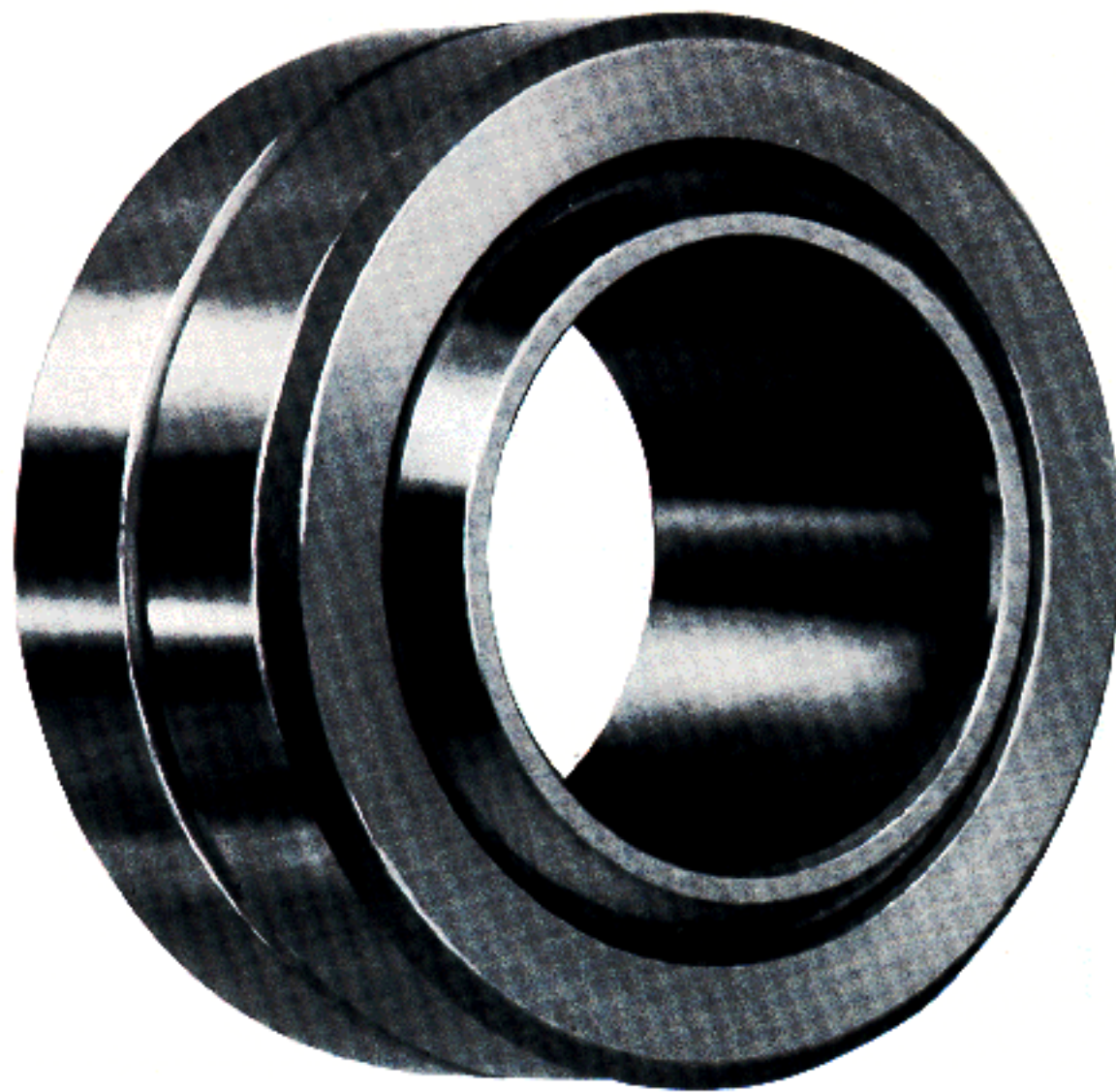

SPHERICAL

# SPHERCO®

## Commercial Series Self-Lubricating - Fiberglide®

### Series COM T

SPHERICAL BEARING NUMBER	DIMENSIONS IN INCHES							MAXIMUM STATIC RADIAL LOAD	APPROX WEIGHT
	BORE	OUTSIDE DIAMETER	BALL WIDTH	HOUSING WIDTH	CHAMFER	BALL DIAMETER	BALL FLAT DIAMETER		
	B	D	W	H	C	E	O		
	+0.0015 -0.0005	+0.0000 -0.0007	+0.005 -0.005	+0.010 -0.010	+0.015 -0.000	REF	REF		
COM3T	.1900	.5625	.281	.218	.020	.406	.293	3,250	.02
COM4T	.2500	.6562	.343	.250	.022	.500	.364	4,900	.02
COM5T	.3125	.7500	.375	.281	.032	.562	.419	6,450	.03
COM6T	.3750	.8125	.406	.312	.032	.625	.475	8,250	.04
COM7T	.4375	.9062	.437	.343	.032	.687	.530	10,200	.05
COM8T	.5000	1.0000	.500	.390	.032	.781	.600	13,600	.07
COM9T	.5625	1.0937	.562	.437	.032	.875	.670	15,900	.09
COM10T	.6250	1.1875	.625	.500	.032	.968	.739	21,000	.12
COM12T	.7500	1.4375	.750	.593	.044	1.187	.920	30,000	.21
COM14T	.8750	1.5625	.875	.703	.044	1.312	.980	41,100	.27
COM16T	1.0000	1.7500	1.000	.797	.044	1.500	1.118	54,700	.38

**Outer Member:** Carbon steel, with protective coating for corrosion resistance on all surfaces exposed after installation

**Ball:** 52100 Alloy steel, heat treated, chrome plated

**Liner:** Fiberglide®

#### NOTES

- ① For design options, see page 21
- ② For Engineering data, see pages 32 and 33
- ▶ See Featured Product Notes, Pages 14 and 15

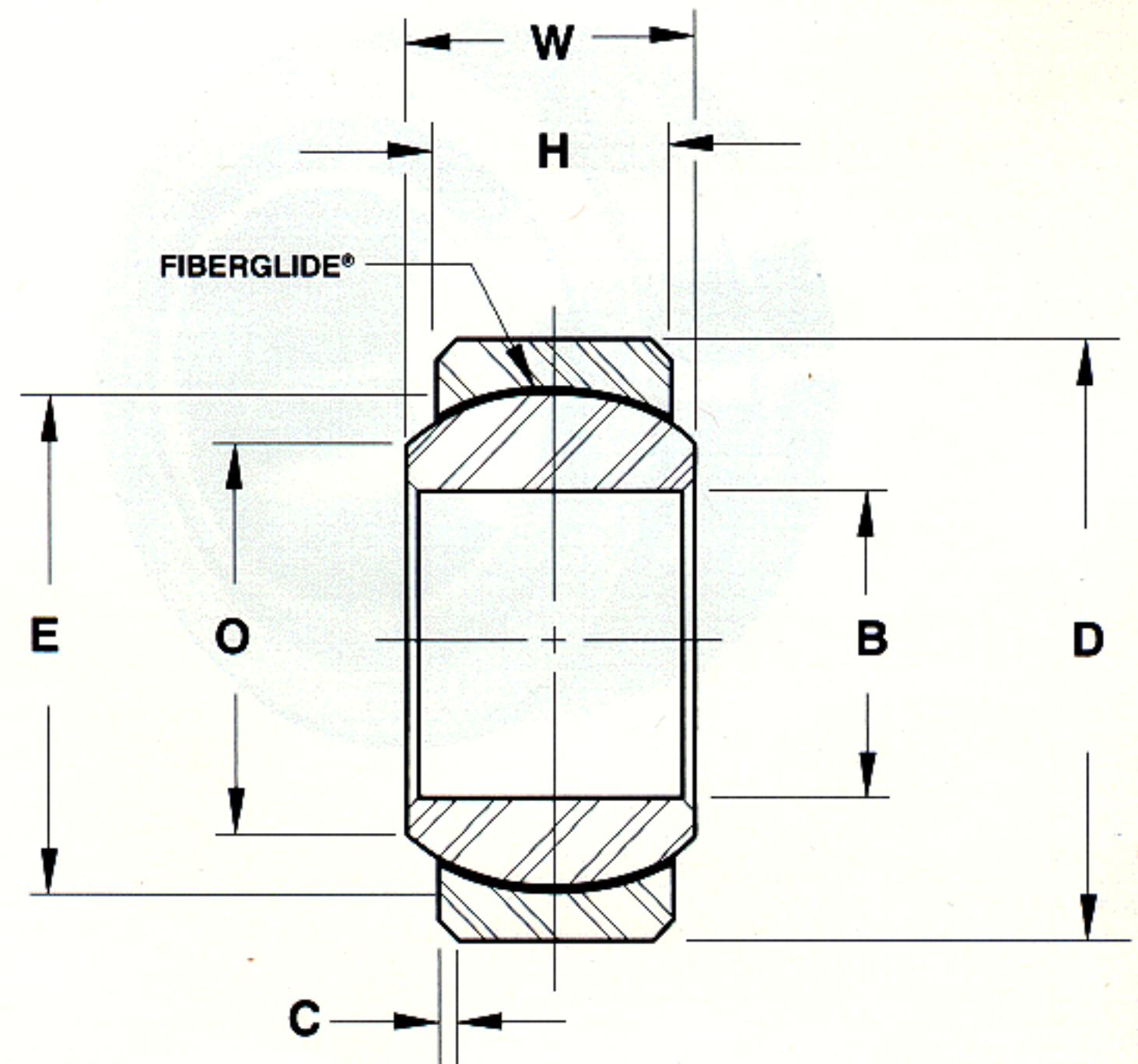
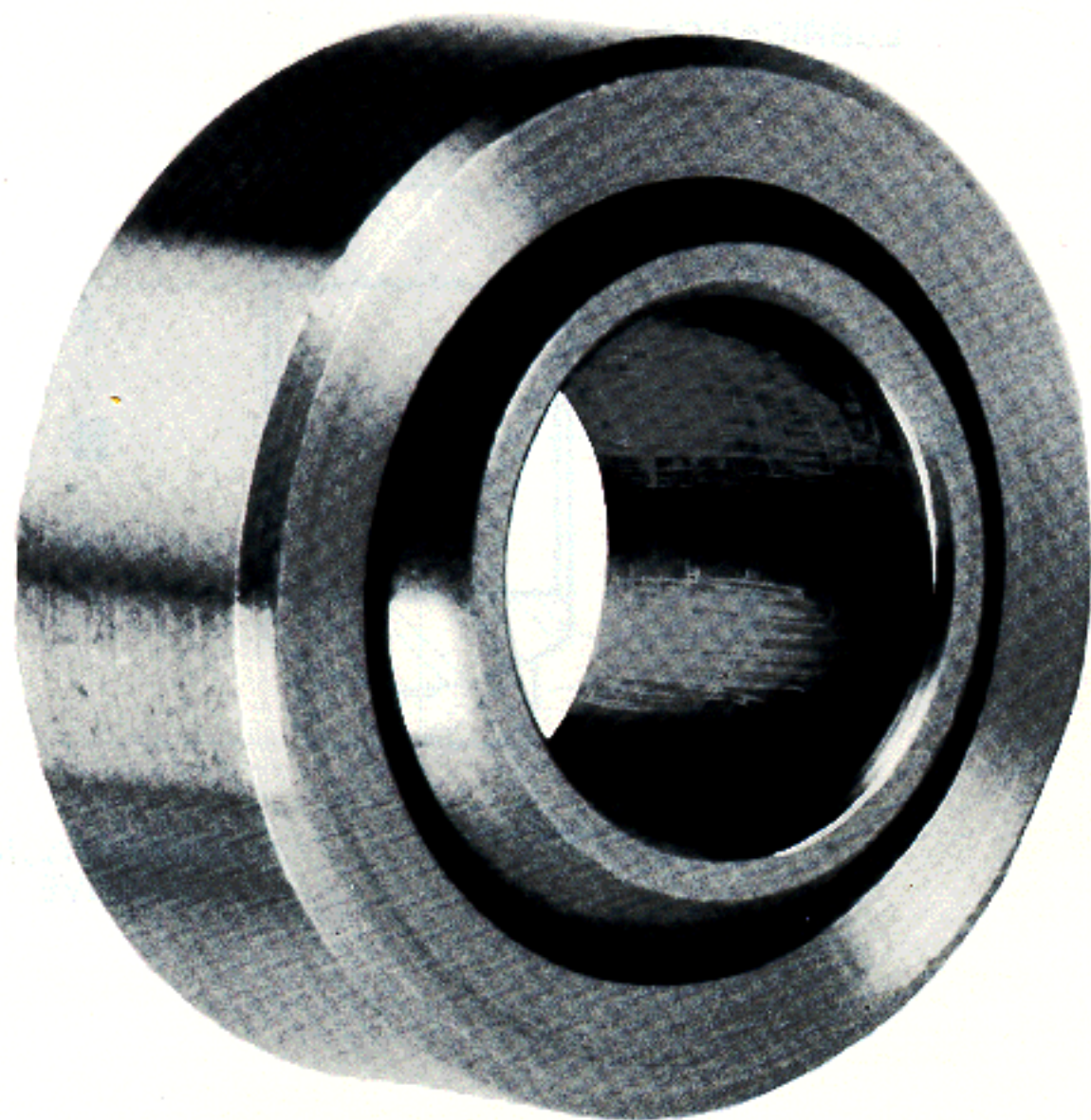

SPHERICAL BEARINGS

# SPHERCO

## Commercial Extra Duty Series Two Piece - Metal to Metal

### Series BH LS

SPHERICAL BEARING NUMBER	DIMENSIONS IN INCHES							MAXIMUM STATIC RADIAL LOAD
	BORE	OUTSIDE DIAMETER	BALL WIDTH	HOUSING WIDTH	CHAMFER	BALL DIAMETER	BALL FLAT DIAMETER	
	B	D	W	H	C	E	O	LBF
	+0.0015 -0.0005	+0.0000 -0.0007	+0.000 -0.005	+0.007 -0.007	+0.015 -0.000	REF	REF	
<b>BH16LS</b>	1.0000	2.0000	1.000	.781	.035	1.688	1.360	68,525
<b>BH19LS</b>	1.1875	2.3750	1.187	.937	.035	2.000	1.610	97,440
<b>BH20LS</b>	1.2500	2.3750	1.187	.937	.035	2.000	1.610	97,440
<b>BH24LS</b>	1.5000	2.7500	1.375	1.094	.035	2.313	1.860	131,550
<b>BH28LS</b>	1.7500	3.1250	1.562	1.250	.040	2.625	2.080	169,000
<b>BH32LS</b>	2.0000	3.5000	1.750	1.375	.040	2.938	2.360	209,985

**Outer Member:** Carbon steel, with protective coating for corrosion resistance on all surfaces exposed after installation

**Ball:** 52100 Alloy steel, heat treated, chrome plated

#### NOTES

- For design options, see page 21
- For Engineering data, see pages 32 and 33

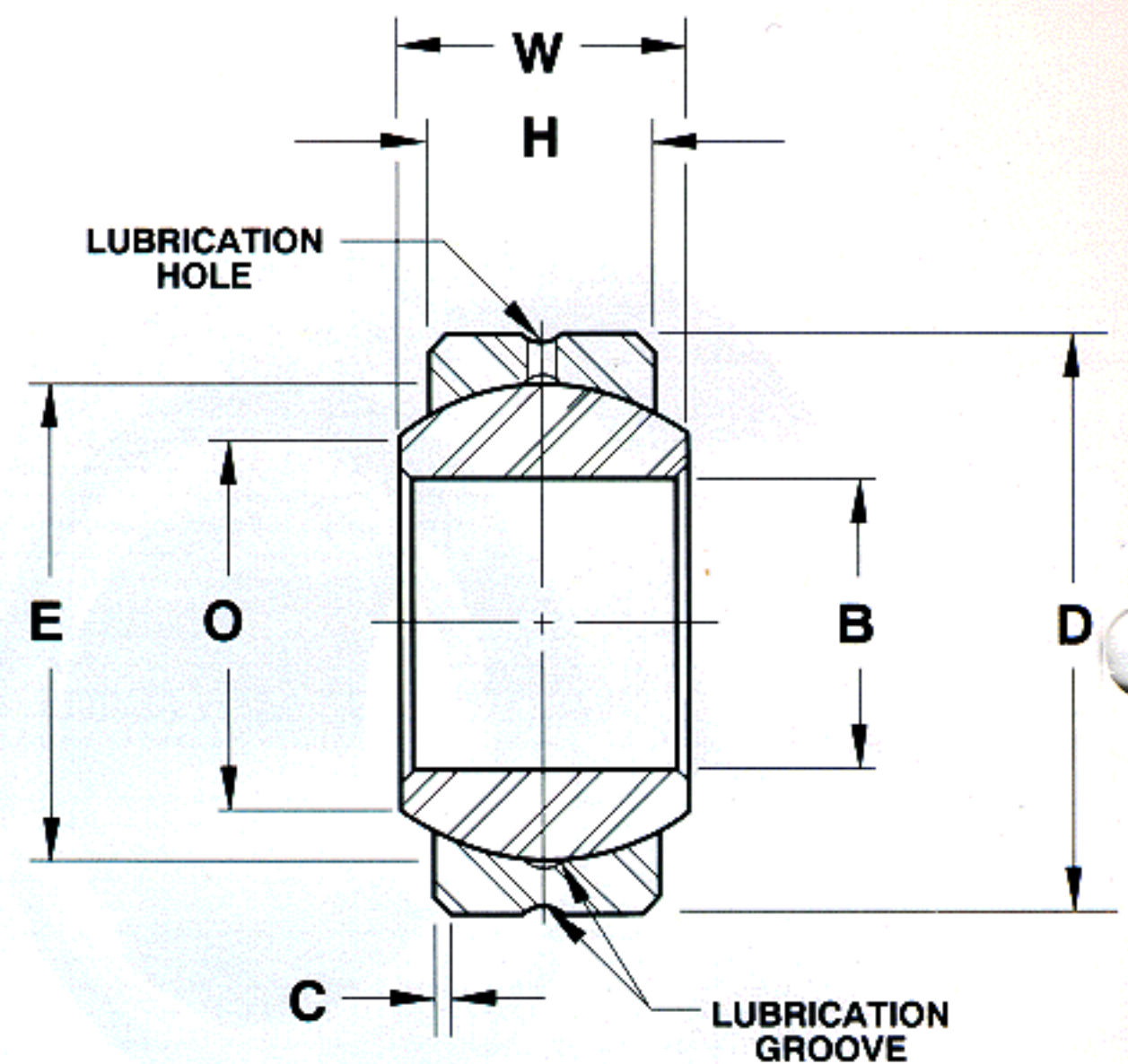

SPHERICAL



# SPHERCO

## Commercial Extra Duty Series Two Piece - Metal to Metal - Sealed

### Series BTS LS

SPHERICAL BEARING NUMBER	BORE	OUTSIDE DIAMETER	HOUSING WIDTH	BALL WIDTH	BALL DIAMETER	BALL FLAT DIAMETER	APPROX. ANGLE OF MISALIGNMENT W/SEALS DEGREES	MAXIMUM STATIC RADIAL LOAD LBF	APPROX WEIGHT LBS
	B	D	H	W	E	O			
	+0.0000 -0.0007	+0.0000 -0.0007	+0.000 -0.005	+0.000 -0.005	REF	REF			
<b>BTS12LS</b>	.7500	1.5000	.500	1.250	1.250	1.000	12 1/2	31,500	.25
<b>BTS16LS</b>	1.0000	2.2500	.875	1.875	1.813	1.375	12 1/2	83,500	.95
<b>BTS20LS</b>	1.2500	2.3750	.875	1.875	2.000	1.625	12 1/2	94,000	.99
<b>BTS24LS</b>	1.5000	2.7500	1.000	1.875	2.375	2.000	12 1/2	130,000	1.44

**Outer Member:** Carbon steel, with protective coating for corrosion resistance  
**Ball:** 52100 Alloy steel, heat treated, chrome plated  
**Seals:** Synthetic rubber

#### NOTES

- For design options, see page 21
- For Engineering data, see pages 32 and 33

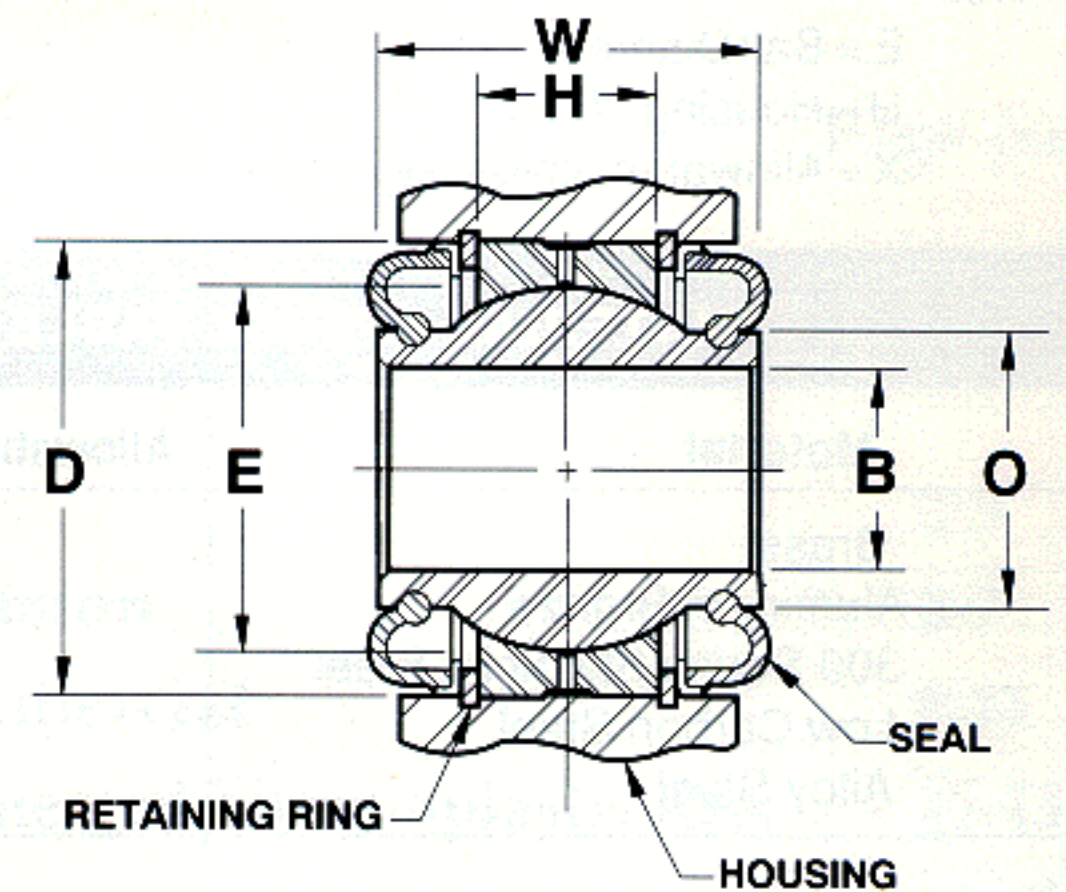
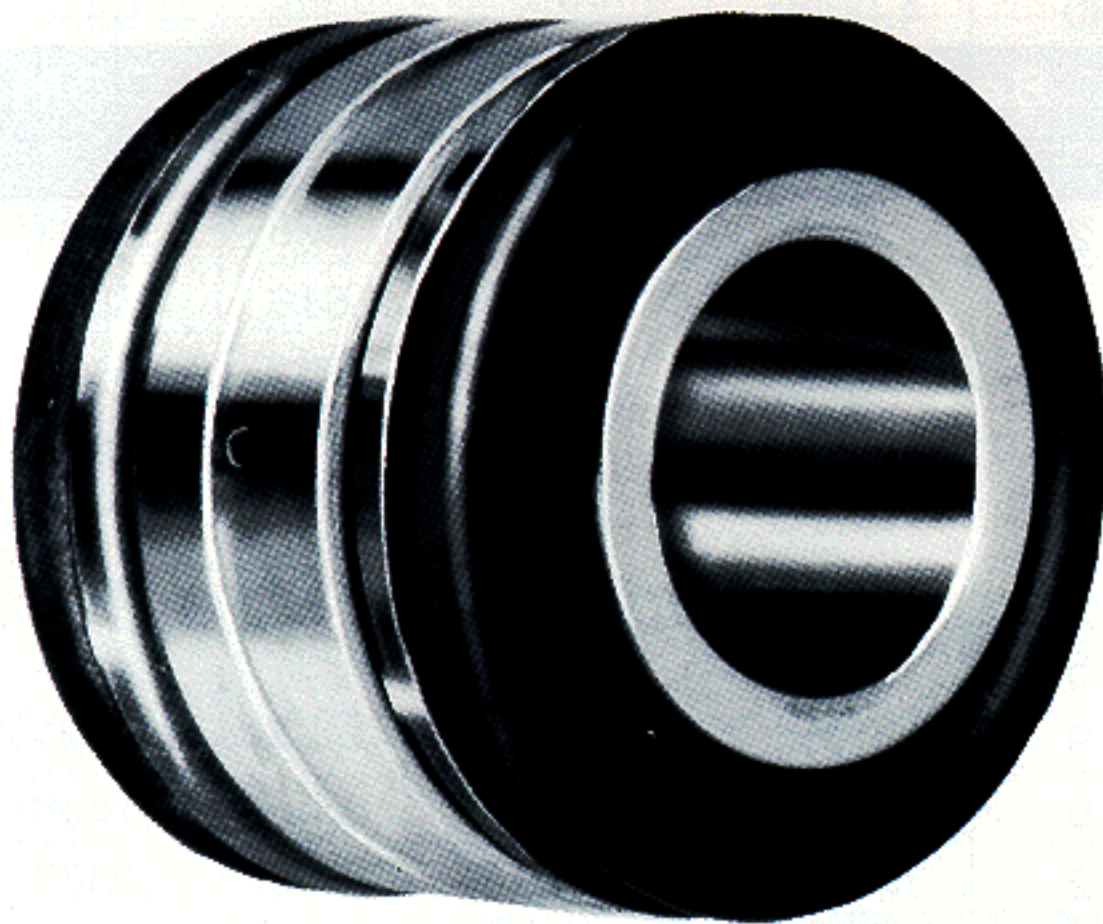

### Housing Bore and Snap Ring Design Guide

HSG. WIDTH	BEARING NUMBER	F	RECOMMENDED HSG. BORE A	RECOMMENDED SNAP RING	J	C
1.250 (Ref.)	<b>BTS12LS</b>	.505	1.5002	TRUARC #5000-150	1.584	.060
		.500	1.4997	SPIROLOX #RR-150	1.576	.056
1.687 (Ref.)	<b>BTS16LS</b>	.879	2.2502	TRUARC #5000-225	2.376	.091
		.875	2.2497	SPIROLOX #RR-225	2.364	.086
1.687 (Ref.)	<b>BTS20LS</b>	.879	2.3753	TRUARC #5000-237	2.511	.091
			2.3747	SPIROLOX #RR-237	2.499	.086
1.875 (Ref.)	<b>BTS24LS</b>	1.005	2.7502	TRUARC #5000-275	2.906	.108
		1.000	2.7497	SPIROLOX #RR-275	2.894	.103
					2.847	.058
					2.841	.055

NOTE: Snap rings not supplied with bearing

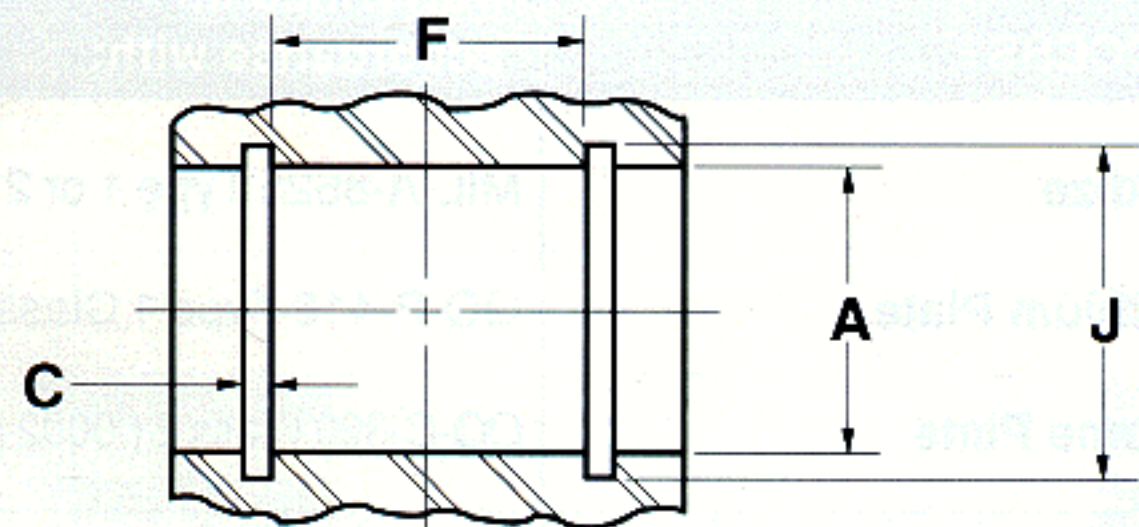

SPHERICAL

## Spherical Bearing Technical Data

### RADIAL LOAD

The maximum static radial load is calculated using the following formula:

$$R = E \times H \times X$$

### STATIC AXIAL LOAD

The maximum static axial load is calculated using the following formulae:

- Axial Strength (A)

1. For four piece insert construction bearings

$$A = .78 [(E + .176H)^2 - E^2] \times X$$

2. For two piece (cartridge type) bearings

$$A = .65(H^2) \times X$$

Where:

E = Ball Diameter

H = Housing Width

X = Allowable Stress (see table below)

### MATERIAL STRESS TABLE

Material	Allowable Stress (PSI)
Brass	30,000
Aluminum Bronze	35,000
300 Series Stainless Steel	35,000
Low Carbon Steel	52,000
Alloy Steel	140,000

### MILITARY SPECIFICATIONS

Many of the processes used by Heim in the manufacture of spherical bearings are performed to U.S. Military Specifications. A partial list of these specifications follows:

PROCESS	Performed in accordance with:
Anodize	MIL-A-8625 Type 1 or 2
Cadmium Plate	QQ-P-416 Type 1 Class 2
Chrome Plate	QQ-C-320 Class 2 (.0002 min)
Heat Treat	MIL-H-6875 MIL-H-7199
Magnetic Particle Inspection	ASTM-E-1444
Penetrant Inspection	ASTM-E-1417
Zinc Plate	ASTM B633, Type III, SC 1 or 2, with chromate coating

### HOUSING BORES

SPHERICAL BEARING SIZE	BEARING OD D	HOUSING BORE			
		STEEL		ALUMINUM	
	+0.0000 -0.0005	MAX	MIN	MAX	MIN
<b>Series FLBG</b>					
3	.6250	.6245	.6241	.6244	.6239
4	.7500	.7495	.7491	.7494	.7489
5	.8750	.8745	.8741	.8744	.8739
6	1.0000	.9995	.9991	.9994	.9989
7	1.1875	1.1870	1.1865	1.1869	1.1863
8	1.3125	1.3120	1.3115	1.3119	1.3113
10	1.5625	1.5620	1.5613	1.5619	1.5611
12	2.2500	2.2495	2.2488	2.2494	2.2486
16	2.3750	2.3745	2.3738	2.3744	2.3736
19	2.6250	2.6245	2.6238	2.6244	2.6236
24	3.2500	3.2495	3.2488	3.2494	3.2486
30	4.0000	3.9995	3.9988	3.9994	3.9986
<b>Series FSBG, SBG S, SBG, COM T, COM, COR</b>					
2	.4687	.4682	.4678	.4681	.4676
3	.5625	.5620	.5616	.5619	.5614
4	.6562	.6557	.6553	.6556	.6551
5	.7500	.7495	.7491	.7494	.7489
6	.8125	.8120	.8116	.8119	.8114
7	.9062	.9057	.9053	.9056	.9051
8	1.0000	.9995	.9991	.9994	.9989
9	1.0937	1.0932	1.0928	1.0931	1.0926
10	1.1875	1.1870	1.1866	1.1869	1.1864
12	1.4375	1.4370	1.4366	1.4369	1.4364
14	1.5625	1.5620	1.5616	1.5619	1.5614
16	1.7500	1.7495	1.7491	1.7494	1.7489

## MISALIGNMENT SPECIFICATIONS

The angle of misalignment in a spherical bearing is calculated somewhat differently from that of the rod end because the housing is not spherical. There are three different types of mountings in which these bearings may be used as shown, and the angle of misalignment is governed by the type of mounting adopted.

Shown below are the common mountings for spherical bearings and the corresponding formula for calculating the angle of misalignment.

SPHERICAL BEARING PART NUMBER	MAXIMUM MISALIGNMENT (+/- DEGREES)		
	b <sub>1</sub>	b <sub>2</sub>	b <sub>3</sub>
<b>FLBG</b>			
3	9.0	16.5	34.5
4	8.0	14.5	29.0
5	9.0	14.0	30.0
6	8.0	12.5	27.0
7	6.5	11.0	25.0
8	7.5	12.5	23.0
10	8.0	12.0	23.0
12	9.0	15.0	27.0
16	6.5	10.0	25.0
19	6.0	8.5	23.5
24	5.0	7.0	23.0
30	5.0	7.0	25.0
<b>FSBG, SBG S, SBG, SBG SS, COM T, COM, COR</b>			
2	8.5	13.5	28.0
3	7.0	11.0	29.5
4	9.0	13.0	30.0
5	8.0	12.0	26.0
6	7.5	10.5	23.5
7	6.5	9.5	20.5
8	7.0	10.0	20.0
9	7.5	10.0	20.0
10	7.0	9.0	19.0
12	7.0	9.0	21.0
14	7.0	9.0	16.0
16	7.5	9.5	16.0
<b>BH LS</b>			
16	6.5	8.5	26.0
19	6.0	8.0	25.5
20	6.0	8.0	23.0
24	6.0	8.0	21.0
28	6.0	8.0	19.0
32	6.0	8.5	19.0

### Reference Letters

B = Bore of ball  
 C = Chamfer on outer race  
 D = Head diameter or diameter of outer race

E = Ball diameter  
 H = Housing width  
 $V = \sqrt{(D - 2C)^2 + H^2}$   
 W = Ball width

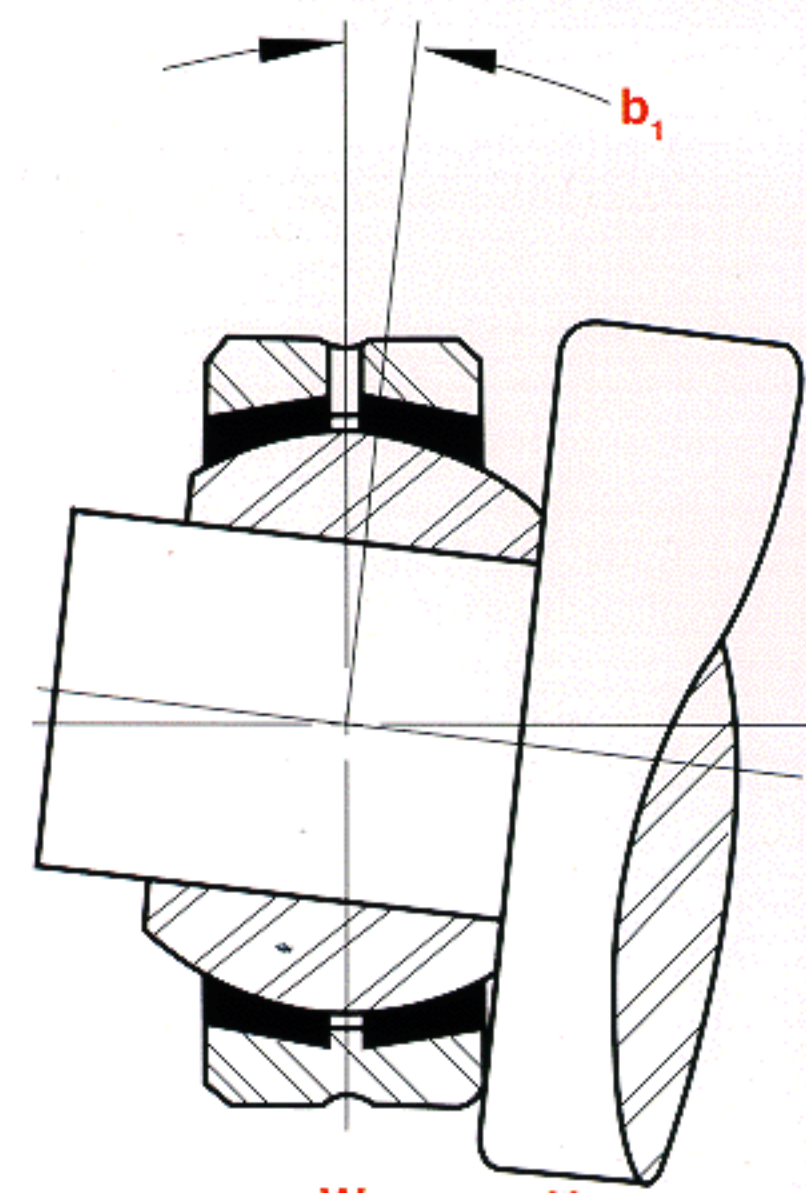

$$b_1 = \sin^{-1} \frac{W}{V} - \sin^{-1} \frac{H}{V}$$

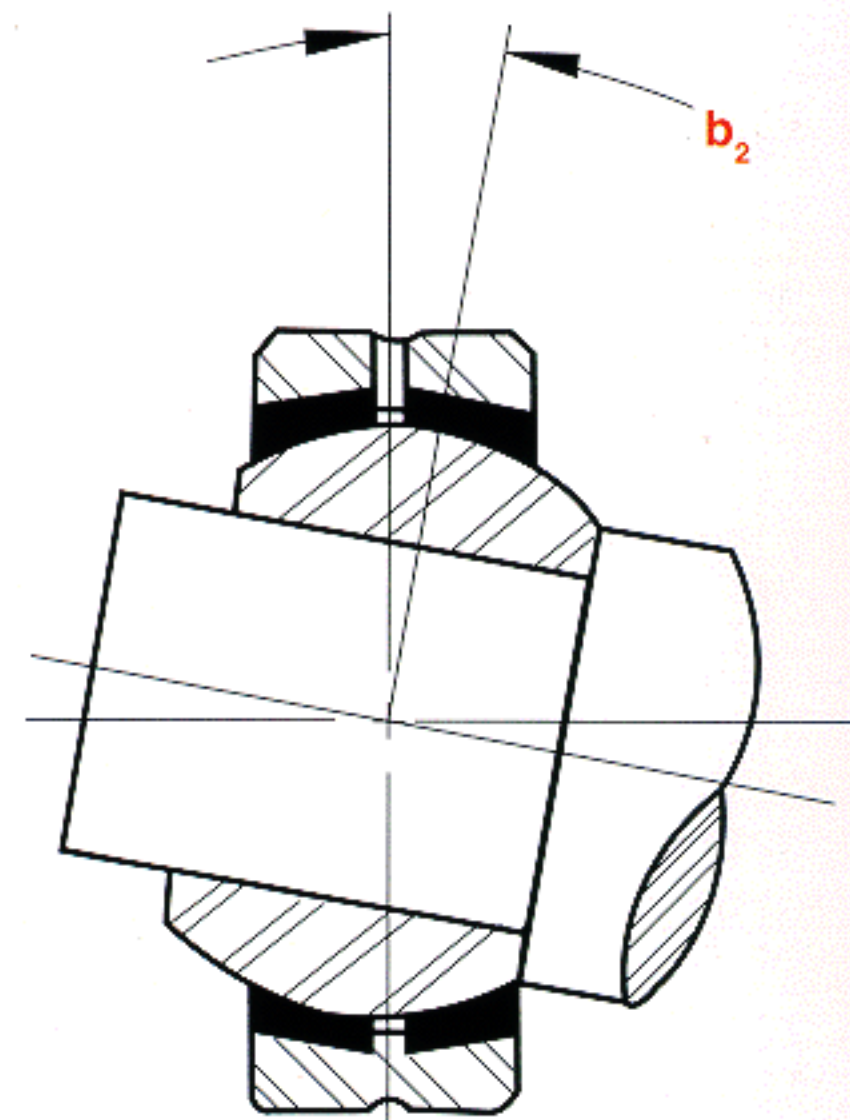

$$b_2 = \sin^{-1} \frac{W}{E} - \sin^{-1} \frac{H}{E}$$

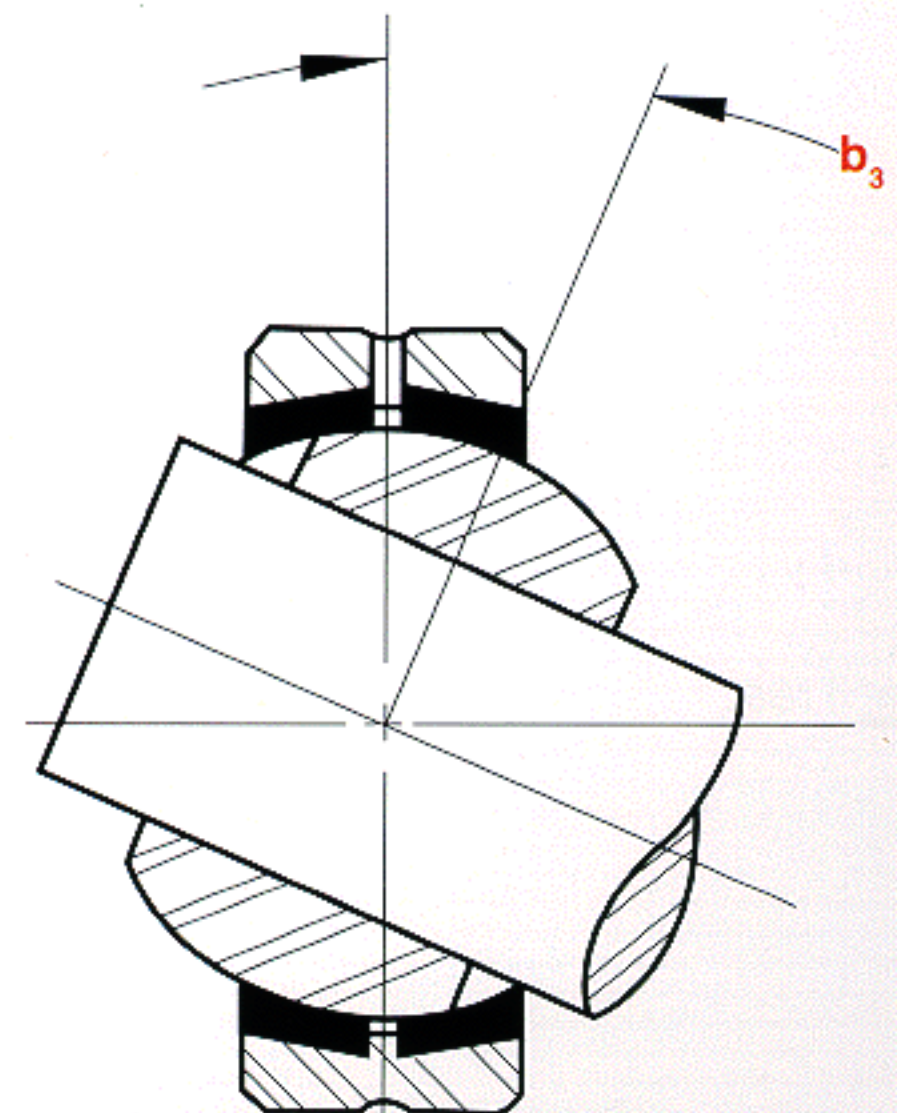

$$b_3 = \cos^{-1} \frac{B}{E} - \sin^{-1} \frac{H}{E}$$

# Innovation. Commitment. Quality.

RBC Bearings has been producing bearings in the USA since 1919. In addition to unique custom bearings, RBC offers a full line of standard industrial and aerospace bearings, including:



## Spherical Plain Bearings

Radial, angular contact, extended inner ring, high misalignment. QuadLube®, ImpactTuff®, SpreadLock® Seal, CrossLube®, DuraLube™, and self-lubricating bearings. Available in inch and metric sizes.



## Thin Section Ball Bearings

Standard cross sections to one inch. Sizes to 40 inches. Stainless steel and other materials are available. Seals are available on all sizes and standard cross sections. Super duplex configurations.



## Tapered Roller Bearings

Tyson® case-hardened and through-hardened tapered roller bearings. Available in many sizes. Used in Class 8 heavy truck and trailer wheel bearings, gear boxes, and final drive transmissions.



## Tapered Roller Thrust Bearings

Case-hardened. Sealed and unsealed for truck, tractor, and construction equipment steer axles, and Class 8 trailer landing gear.



## Integrated Assemblies

For robots and other process tool applications. Engineering design assistance. Production volume capacity.



## Cam Followers

Standard stud, heavy stud, yoke type, caged roller followers. Patented RBC Roller® cylindrical roller cam followers, HexLube® universal cam followers, airframe track rollers.



## Needle Roller Bearings

Pitchlign® caged heavy duty needle roller bearings, inner rings, TJ TandemRoller® bearings for long life.



## Self-Lubricating Bearings

Radial, thrust, rod ends, spherical bearings, high temperature, high loads. Available in inch and metric sizes. Fiberglide® self-lubricating bearings.



## Airframe Control Bearings

Ball bearing types, self-lubricating types, needle roller track rollers.



## Dowel Pins, Loose Needle Rollers, Shafts

Precision Products dowel pins, loose needle rollers, and shafts.



## Commercial Rod Ends

Commercial and industrial, precision, Mil-Spec series, self-lubricating, and aircraft. Sold under the Heim®, Unibal®, and Spherco® brands. Available in inch and metric sizes.



## Ball Bearings

Precision ground, semi-ground, unground. High loads, long life, smooth operation. Nice® ball bearings are offered in caged and full complement configurations.



## Specials

RBC manufactures many specialty bearings for the aerospace, oil and energy, semiconductor equipment, packaging, transportation, and other industries.